

5C/A750 ADA - WATER CLOSET - FLOOR PLAN
1/2"=1'-0"

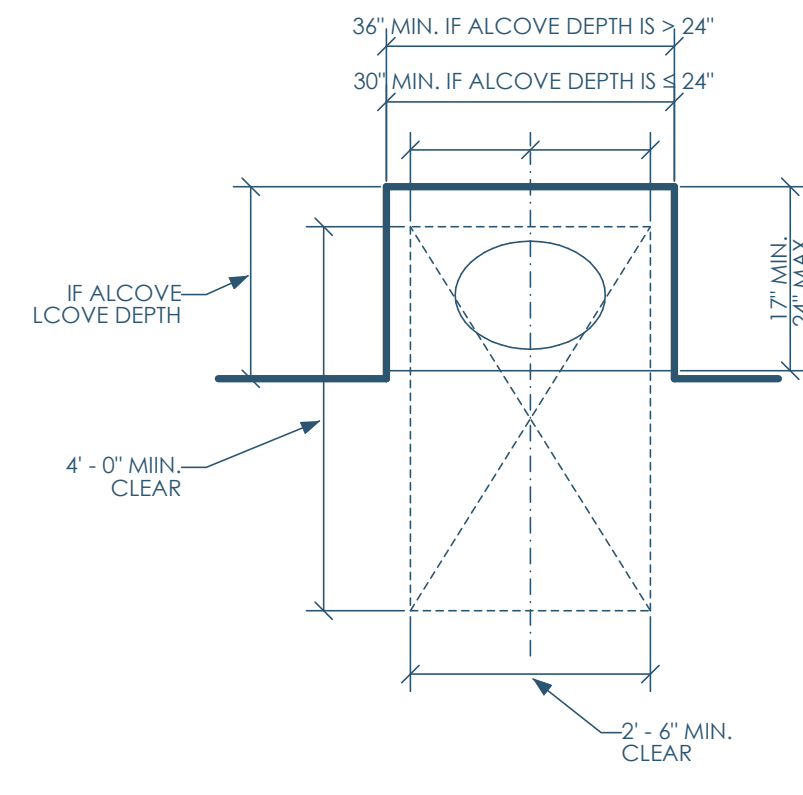

4C/A750 ADA - LAVATORY - PLAN
1/2"=1'-0"

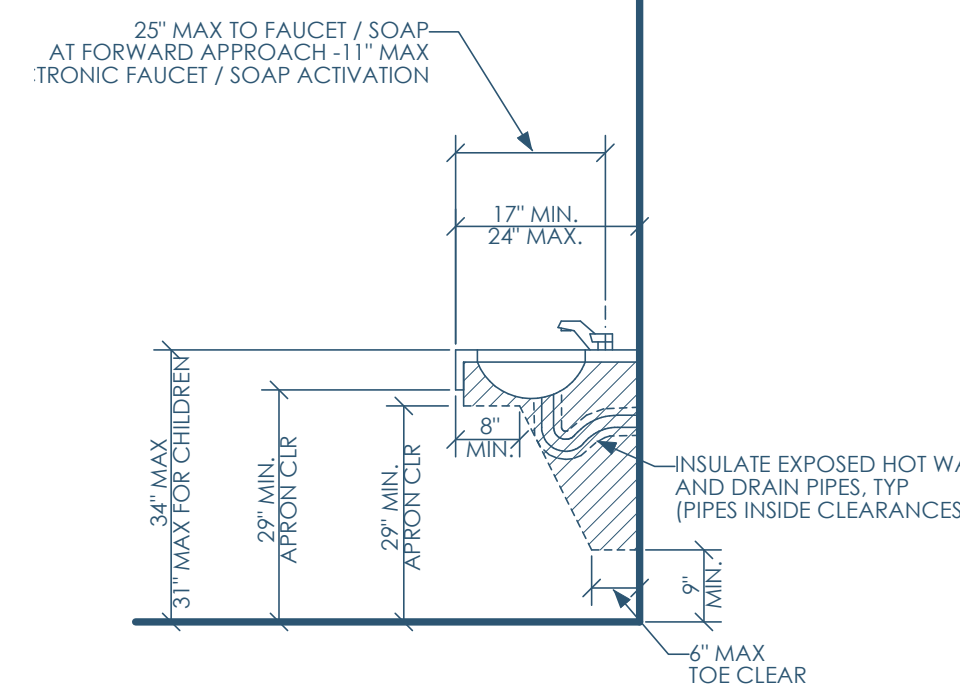

3C/A750 ADA - LAVATORY - SIDE
1/2"=1'-0"

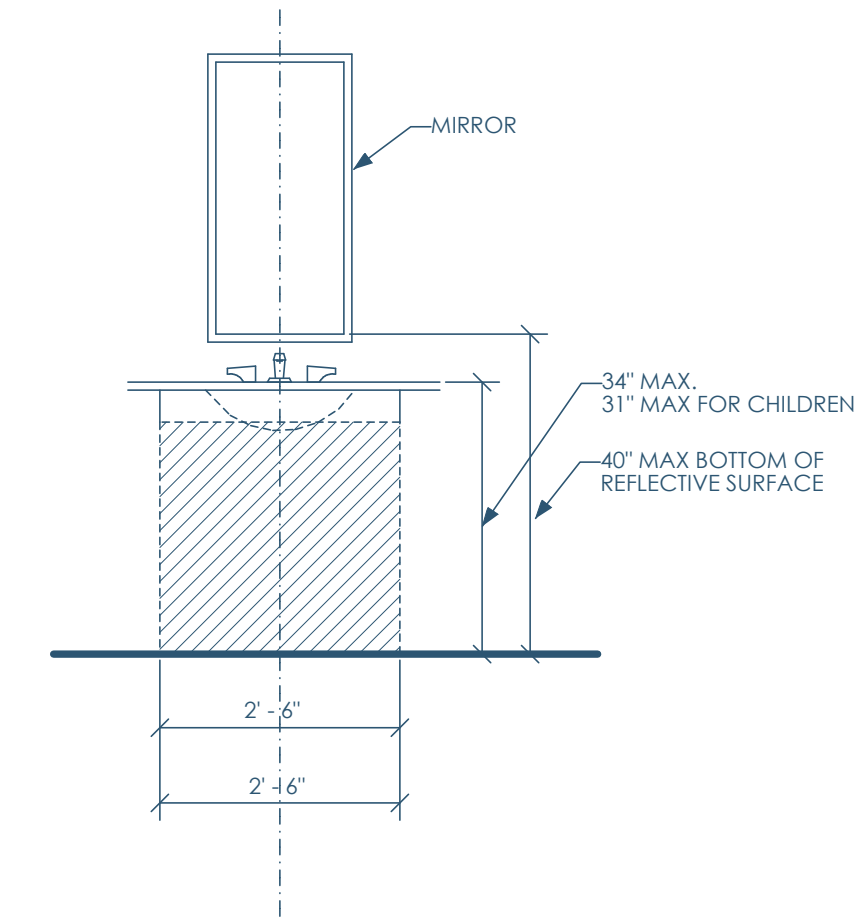

2C/A750 ADA - LAVATORY - FRONT
1/2"=1'-0"

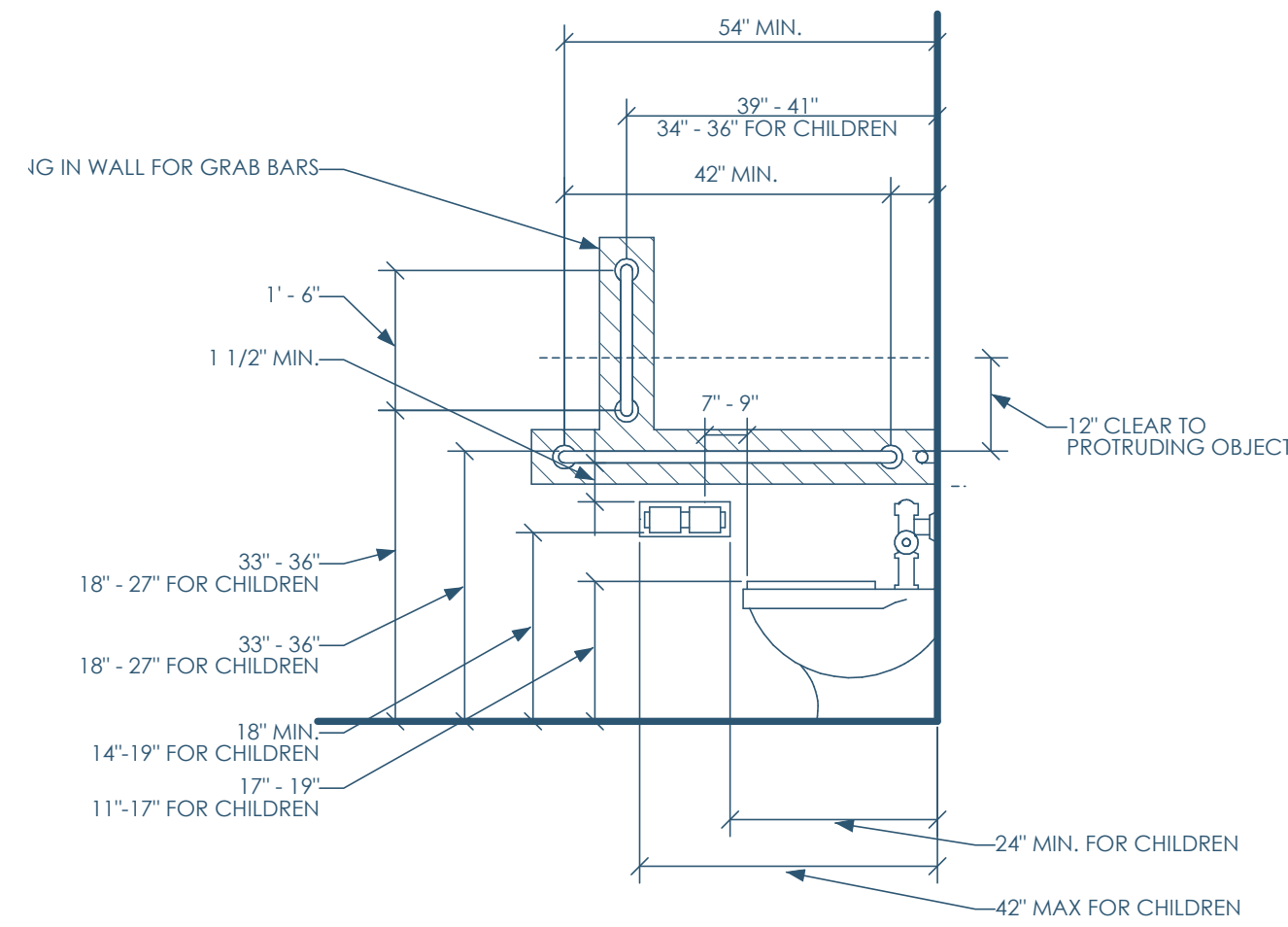

5B/A750 ADA - WATER CLOSET - SIDE
1/2"=1'-0"

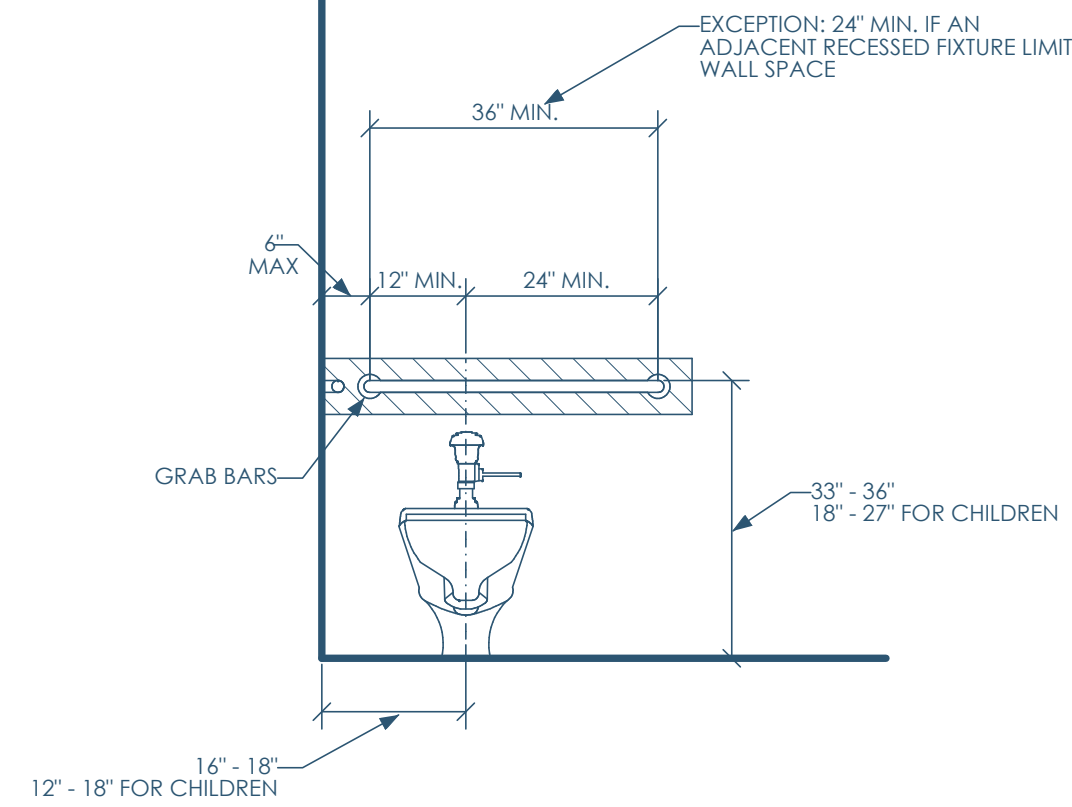

4B/A750 ADA - WATER CLOSET - FRONT
1/2"=1'-0"

GENERAL RESTROOM NOTES
 PER IBC1210.2.2 WALLS AND PARTITIONS WITHIN 2 FEET (610MM) OF SERVICE SINKS, URINALS AND WATER CLOSETS SHALL HAVE A SMOOTH, HARD, NONABSORBENT SURFACE TO A HEIGHT OF NOT LESS THAN 4 FEET (1219 MM) ABOVE THE FLOOR, AND EXCEPT FOR STRUCTURAL ELEMENTS, THE MATERIAL USED IN SUCH WALLS SHALL BE OF A TYPE THAT IS NOT ADVERSELY AFFECTED BY MOISTURE

1A/A750 GENERAL RESTROOM NOTES



Owner: All Surfaces
5525 Tradesmen Dr
Madison, WI 53718
allsurfaces.com | 952.884.6033



GC: Lake Country Construction Group
161 Horizon Dr
Verona, WI 53593
608.845.1398



Architect: Opening Design
17 S Fairchild | FL 7
Madison, WI 53703
ryan@openingdesign.com | 773.425.6456

This project, like most OpeningDesign's projects, is open source. (Attribution-ShareAlike 4.0 International=CC-BY-SA 4.0)=freely available to any party for future use, assuming the terms such as Attribution and ShareAlike are honored.