



Chapter SPS 321 Subchapter I — Scope

321.02 Load Paths

Individual structural members need their load paths analyzed all the way to grade for adequate load transfer. This may require additional wall studs or joist bay blocking below point loads. If such supports have a header in them, typically separate structural analysis must be provided to properly size this header and those supporting jamb columns.

321.02 (1) (a) Dead Load of Insulation

To avoid ceiling gypsum board sag or related problems, attic insulation dead load should not exceed gypsum board manufacturer's recommended capacity. This is especially true today where thick attic insulation and 24-inch truss spacing are common.

Attic insulation materials vary in density and thermal properties. Therefore, the total weight per installed R-value will vary depending on type, installation method and manufacturer of insulation product. Some typical values are estimated below; check actual weights supplied from your manufacturer or installer.

<u>Type</u>	<u>Density</u>	<u>R/Thickness</u>	<u>R-38 Weight</u>	<u>R-50 Weight</u>
Cellulose	2.4 pcf	3.6/inch	2.1 psf	2.8 psf
Blown Mineral Wool	1.2 pcf	2.8/inch	1.4 psf	1.8 psf
Blown Fiberglass	0.6 pcf	2.7/inch	0.7 psf	1.0 psf
Loose Fill Fiberglass	1.1 pcf	2.5/inch	1.4 psf	1.4 psf
Fiberglas Batt R(19+19+13)	0.7 pcf	3.2/inch	0.7 psf	0.9 psf
Rigid (expanded polystyrene)	1.8 pcf	4.0/inch	1.4 psf	1.9 psf
Rigid (extruded polystyrene)	2.2 pcf	5.0/inch	1.4 psf	1.8 psf
Spray (polyurethane foam)	1.9 pcf	6.2/inch	1.0 psf	1.3 psf
Spray (open cell)	0.5 pcf	3.3/inch	0.4 psf	0.6 psf
Mineral fiber (rockwool)	2.0 pcf	2.3/inch	2.8 psf	3.6 psf

321.02 (1) (b) 2. Live Load - Snow

Exterior balconies or decks should be designed to withstand 40 PSF as the critical live load. The effect of drifting or sliding snow on a roof should be considered as a matter of good design practice. However, the UDC only requires a 30 or 40 PSF snow load applied uniformly to roofs. In complex roofs with side by side low-high portions or flat roofs below sloped upper roofs, a designer may want to consider potentially higher snow loads in the low roof areas where sliding or drifting snow may collect.

321.02(1)(c)

The UDC does not set reduced snow live load values for roofs with glass or other slippery surfaces. SPS 321.27(1) (c) does allow a reduced snow load for steeper roofs with slopes of 7 in 12 or greater. Otherwise, attached greenhouses, solar spaces, solar panels and other similar roof construction should be designed to withstand 40 or 30 PSF for zone 1 or 2 respectively.

321.02(1)(c) Wind Design

Lateral wind forces can cause a building to rack, slide, or overturn, as well as uplift. All of these potential movements need to be addressed by the building design.

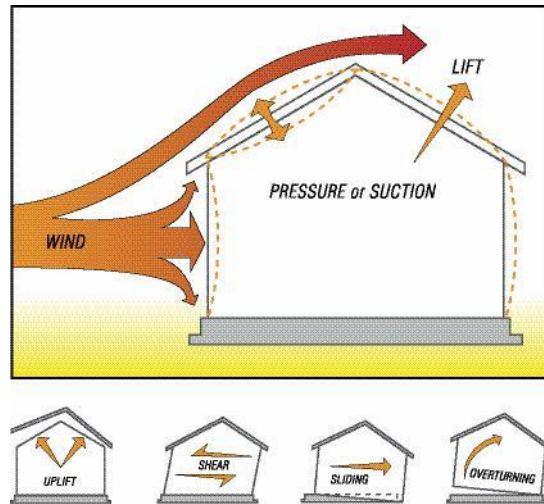

Racking:

When wind blows against the side of the structure exerting a lateral force that causes it to lean over (rack) to one side.

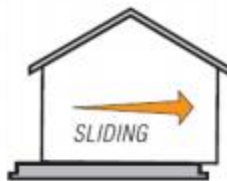

Sliding:

When wind blows against the side of the structure exerting a lateral force, causing it to slide off of its foundation.



Overturning:

When the structure is anchored in place to limit racking or sliding, the lateral force of the wind causes the structure to rotate or overturn.

Question When designing the braced wall lines to comply with SPS 321.25(8)(1), may I use the ASCE 7 standard as an option to determine wind loads on a dwelling even though the resultant wind pressure may be less than 20 PSF?

Answer Yes. ASCE 7 is considered an accepted engineering practice. Conditions of acceptance are: that version 2005 is used, that a minimum wind speed of 90 MPH (3-second gust) be used, that the appropriate exposure factor be used, and that it be applied to the whole dwelling for determining wall bracing. The ASCE 7 standard may also be used to determine the wind pressure on tall walls only if the ASCE 7 design standard is also being used for determining the wall bracing requirements of the dwelling. This design methodology may also be used to determine wall bracing needs for an addition, and only the addition, to an existing dwelling as long as it is applied to the complete addition.

321.02 (1) (d) Fasteners

The fastener schedule in table 321.02-2 presents one means of showing adequate fastening to meet the code in most typical designs with sawn lumber. However, it may not be sufficient for certain designs, especially those using engineered lumber that can handle greater spans and loads than those assumed in the appendix fastener table. Be sure to verify that the fasteners provided will adequately transfer the greater loads that required special lumber.

There have been questions about the use of fasteners of different sizes, types and spacing to those provided in the existing fastener schedule. Below is a Table with a list of alternate fastener sizes, types and spacing for braced wall panels that could be used to comply with the provisions of s. SPS 321.10 (3) (h). There is also a link in footnote 4 of another resource that would be available to find other fastener equivalencies.

ALTERNATE FASTENING SCHEDULE FOR BRACED WALL PANELS⁴					
Alternatives to the Fastener Schedule Table in UDC Appendix as referenced by s. SPS 321.02 (3) (h)					
Item	Material	Fastener		Spacing of Fastener	
		Type	Minimum Nominal Length	Edges	Intermediate Supports
	Wood structural panel for wind bracing to wall framing				
1	5/16" to 1/2"	0.113" nail (6d common nail)	2"	6"	12"
2		0.113" deformed shank nail ¹	2" 2-3/8"	6"	12"
3		14 gage staple ²	2" 2-1/4" 2-1/2" 3"	6"	12"
4		15 gage staple ²	1-3/4" 2" 2-1/4" 2-1/2"	6"	12"
5	5/8" to 3/4"	0.131" nail (8d common nail)	2-1/2"	6"	12"
6		0.131" deformed shank nail ¹	2-3/8"	6"	12"
7		0.113" deformed shank nail ¹	2" 2-3/8"	4"	8"
8		14 gage staple ²	2" 2-1/4" 2-1/2" 3"	4"	8"
	1/2" Gypsum Wallboard panel for wind bracing to wall framing (interior) ³				
9		Type W or S screw	1 1/4"	7"	7"
10		Galvanized roofing nail	1 1/2"	7"	7"

Footnotes:

1. Clipped and notched nail heads are permitted. T-type nail heads are not permitted.
2. Staples must have minimum 7/16 inch crown widths.
3. 4' x 8' or 4' x 9' panels shall be applied vertically.
4. For further info, see ICC-ES Report # 1539 at www.icc-es.org

321.02(2) Engineered Design

This code provides various prescriptive, or cookbook, methods of complying with the code requirements, that are typically conservative because of the unknown, specific project conditions. It also allows for individually engineered designs that take advantage of all specific project conditions, as well as alternate generic designs that are based on the UDC loads, materials and methods of design. These generic methods can include tables, calculators, guides and other tools. Their limitations must also be followed. In some cases, these limitations will be more restrictive than that UDC, but are necessary for the overall designs. With proper documentation, conservative substitutions may be allowed. In other cases, these alternate generic designs may differ from the UDC for issues that are not related to the need for the overall design to work. In such cases, per SPS 320.01, the UDC provisions would be the minimum and maximum enforced provisions.

321.02 (2) "Typical" Structural Analysis

Question: A builder submits a building plan and includes "typical" structural calculations. Is there any time limit placed on the acceptability of such calculations?

Answer: Usually the typical calculations correspond to a master plan of a home built repetitively. When reviewing the building plans, you should verify that the loading conditions, spans, member sizes, member spacing and lumber grade as specified in the "typical" calculations are consistent with the plans. The use of such typical calculations or span tables (as in the Appendix to Ch. 321) is generally acceptable as long as the design criteria coincide with the building plans. There would be no time limit on the use of such calculations as long as they do not conflict with the requirements of the current code. An update of the calculations should be required if the code changes and different loads, load duration factors or other design criteria become effective.

321.02 (2) Manufacturer's Installation Requirement

Section SPS 321.02(2), requires that all dwellings be designed by the method of engineering analysis or the method of accepted practice. It is accepted practice to install a material in a manner required by the material's manufacturer, if the installation is regulated by the code. A material installed in a manner that is inconsistent with the manufacturer's **requirements** should not be allowed unless additional information is provided showing that the installation will still meet the performance requirement of the code. An example is listed equipment--if the equipment is not installed per manufacturer requirements, the acceptance provided by the listing is not applicable. A manufacturer's installation requirement must also be checked for compliance with the Uniform Dwelling Code. It is the responsibility of the builder to have manufacturer's installation instructions available for review by the inspector (per s. SPS 320.09) when a question of proper installation arises.

321.02 Engineering Terms Used in the Code or Referenced Standards

1. ALLOWABLE STRESS (F)

- Determined by physical testing of wood specimens of different grades and species.
- Tabulated value already has a built in factor of safety.
- Historically done by visual inspection of wood for defects (knots, checks.....) = Visual Graded.

321.02

- Also can be done by machine by testing deflection-vs-load = Machine Stress Rated (MSR).
2. LATERAL SUPPORT
 - Structural bracing or interconnection that prevents movement of a structural member in a specific direction, usually perpendicular to the direction that the main structural member is providing support.
 - Examples:
 - bridging to joists
 - corner bracing to studs (let-in 1 x 4, metal straps, plywood panels)
 - subfloor to joists
 - sheathing to trusses
 - floor system to foundation walls
 - basement floors to foundation walls
 3. MODULUS OF ELASTICITY (E)
 - Ratio of stress/strain.
 - For a given force applied to a material, you can predict the deformation if you know E.
 4. BENDING MOMENT (M)
 - Force x distance (inch-lbs).
 - Causes curvature deformation in beams or columns.
 - Causes tension and compression stresses in beams and sometimes columns.
 5. MOMENT OF INERTIA (I)
 - Used in the calculation of beam deflection.
 - Geometric property of a structural member.
 - $I = \frac{bd^3}{12}$, inches⁴ (rectangular beam), b = width, d = depth
 6. SECTION MODULUS (S)
 - Geometric property of a structural component (beam, column . . .).
 - $S = M/F_b$, inches³
 - $S = \frac{bd^2}{6}$ (rectangular beam), b = width, d = depth
 7. STRAIN
 - Deformation, (stretching, compaction, curvature) caused by an external force.
 8. STRESS* - Internal resistance to an external force.
 - Generally in lbs/in² (psi).
 - F_b = bending stress;
Resists curvature due to bending moment (Force).
 - F_c, F_t = axial compression or tension stress;

Resists perpendicular compaction or stretching due to a longitudinal force.

- F_v = shear stress;

Resists slippage in plane of the surface parallel to the end face of the beam.

*Capitol (F) denotes "allowable" stresses in a material samples as determined by testing and adjusted by factors permitted by the applicable material standard. Small case (f) denotes "actual" calculated stress of a structural member as based on design loads.

321.02 (3) (b) Outline of the National Design Specification (NDS)

This specification is adopted by the UDC s. SPS 320.24(2)(a) and s. SPS 321.02(3)(b). The NDS is used for structural design of wood members as an alternative or in addition to the prescriptive (accepted practice or "cookbook") standards in Ch. 321. It is the basis for the development of the Fastener Table and the Span Tables in the Appendix of the UDC. Its accompanying NDS Supplement provides allowable stress values depending on grade, species and dimensions of lumber used. It is also the basis for "Design Values For Joist And Rafters-Visual Grading" tables in the Appendix. Note that at the time of promulgation of the UDC on January 1, 2016, the incorrect design values for Southern Pine were printed in Appendix A. Following are the corrected design values for Southern Pine to be used with the floor joist and roof rafter span tables in Appendix A.

TABLE W-1 DESIGN VALUES FOR JOISTS AND RAFTERS - VISUALLY GRADED LUMBER^{1,2}

These F_b values are for use where repetitive members are spaced not more than 24 inches. For wider spacing, F_b values shall be reduced 13%. Values for surfaced dry or surfaced green lumber apply at 19% maximum moisture content in use.

Species and Grade	Size	Design Value in Bending, F_b			Compression perpendicular to grain, $F_{c\perp}$	Modulus of Elasticity, E	Grading Rules Agency	
		Normal Duration	Snow Loading	7-Day Loading				
SOUTHERN PINE								
Dense Select Structural	2x4	3,105	3,570	3,880	660	1,900,000	SPIB	
Select Structural		2,705	3,110	3,380	565	1,800,000		
Non-Dense Select Structural		2,360	2,710	2,945	480	1,600,000		
No.1 Dense		1,900	2,180	2,370	660	1,800,000		
No.1		1,725	1,985	2,155	565	1,600,000		
No.1 Non-Dense		1,495	1,720	1,870	480	1,400,000		
No.2 Dense		1,380	1,585	1,725	660	1,600,000		
No.2		1,265	1,455	1,580	565	1,400,000		
No.2 Non-Dense		1,210	1,390	1,510	480	1,300,000		
No.3 and Stud		750	860	935	565	1,300,000		
Construction		1,005	1,155	1,260	565	1,400,000		
Standard		545	630	685	565	1,200,000		
Utility		260	300	325	565	1,200,000		
Dense Select Structural		2x6	2,760	3,175	3,450	660		1,900,000
Select Structural			2,415	2,775	3,020	565		1,800,000
Non-Dense Select Structural			2,130	2,445	2,660	480		1,600,000
No.1 Dense	1,725		1,985	2,155	660	1,800,000		
No.1	1,555		1,785	1,940	565	1,600,000		
No.1 Non-Dense	1,380		1,585	1,725	480	1,400,000		
No.2 Dense	1,210		1,390	1,510	660	1,600,000		
No.2	1,150		1,325	1,440	565	1,400,000		
No.2 Non-Dense	1,095		1,255	1,365	480	1,300,000		
No.3 and Stud	660		760	825	565	1,300,000		
Dense Select Structural	2x8	2,530	2,910	3,165	660	1,900,000		
Select Structural		2,245	2,580	2,805	565	1,800,000		
Non-Dense Select Structural		1,955	2,250	2,445	480	1,600,000		
No.1 Dense		1,555	1,785	1,940	660	1,800,000		
No.1		1,440	1,655	1,795	565	1,600,000		
No.1 Non-Dense		1,265	1,455	1,580	480	1,400,000		
No.2 Dense		1,120	1,290	1,400	660	1,600,000		
No.2		1,065	1,225	1,330	565	1,400,000		
No.2 Non-Dense		1,005	1,155	1,260	480	1,300,000		
No.3 and Stud		605	695	755	565	1,300,000		
Dense Select Structural	2x10	2,245	2,580	2,805	660	1,900,000		
Select Structural		1,955	2,250	2,445	565	1,800,000		
Non-Dense Select Structural		1,725	1,985	2,155	480	1,600,000		
No.1 Dense		1,380	1,585	1,725	660	1,800,000		
No.1		1,210	1,390	1,510	565	1,600,000		
No.1 Non-Dense		1,095	1,255	1,365	480	1,400,000		
No.2 Dense		980	1,125	1,220	660	1,600,000		
No.2		920	1,060	1,150	565	1,400,000		
No.2 Non-Dense		865	990	1,080	480	1,300,000		
No.3 and Stud		545	630	685	565	1,300,000		
Dense Select Structural	2x12	2,070	2,380	2,590	660	1,900,000		
Select Structural		1,840	2,115	2,300	565	1,800,000		
Non-Dense Select Structural		1,610	1,850	2,015	480	1,600,000		
No.1 Dense		1,265	1,455	1,580	660	1,800,000		
No.1		1,150	1,325	1,440	565	1,600,000		
No.1 Non-Dense		1,035	1,190	1,295	480	1,400,000		
No.2 Dense		920	1,060	1,150	660	1,600,000		
No.2		865	990	1,080	565	1,400,000		
No.2 Non-Dense		805	925	1,005	480	1,300,000		
No.3 and Stud		520	595	645	565	1,300,000		

NDS Part I General Requirements for Structural Design

- Includes guidelines for use of NDS considering the effects of:
 - Bracing
 - Connections at joints
 - Adequate load assumptions
 - Most conservative load combinations
- The NDS is intended to be adopted by governing codes such as the UDC which may prescribe the above minimum load and load combinations.

NDS Part II Design Values for Structural Members

- Allows for modification of design stresses due to:
 - Moisture conditions
 - Temperature
 - Preservative treatment
 - Fire retardant treatment
 - Duration of load.

Not all stress modifications are necessarily applicable to all beam and column installations.

Introduces the concept of a Load Duration Factor (LDF). The LDF will adjust allowable stresses, generally upward, to recognize that wood is more responsive in resisting short term loadings.

- Floor Live Load = 1.0 (10 years)
- Snow Load = 1.15 (2 months)
- Roof Live Load = 1.25 (7 day)
- Earthquake, Wind = 1.6 (10 minutes)
- Impact = 2.00 (2 sec)

NDS Part III Design Provisions and Formulas

1. Beam Design

- Formulas listed in text (also see s. 321.22(3) of this commentary).
- Notching of beams - limitations similar to UDC.
- In general, the NDS assumes rectangular sections (sawn lumber) are used. Certain modification factors can be used for other shaped (round) members. Also, other shaped members will have different geometric properties that will alter the "typical" formulas referenced in this commentary.
- Beam formulas can be complicated by and thereby adjusted to compensate for:
 - lack of lateral support
 - relatively long beam length
 - beam shape: round, rectangle, diamond
- Beam design must also consider:
 - Shear stress (f_v), especially for heavily loaded, short span members.

321.02 (3)

- Deflection considerations, especially for long spans or when the joist/beam depth is relatively small.
2. Column Design, Axial Compression (C)
- Formulas listed in NDS.
 - Compression members can be horizontal or vertical (trusses).
 - Column design is a function of:
 - Area
 - Compressive Stress, f_c
 - Column length, l
 - Column width, d
 - Shape: round, square, tapered
 - There is no one simple formula because of the many interrelated factors listed above.
3. Tension Members, Axial Tension (T)
- Formulas listed in NDS.
 - Member design is a function of:
 - Area
 - Tensile stress, f_t
 - Usually end connections are most critical in design.
4. Combined Axial (T or C) & Bending Stress
- Common in truss design and pole buildings.

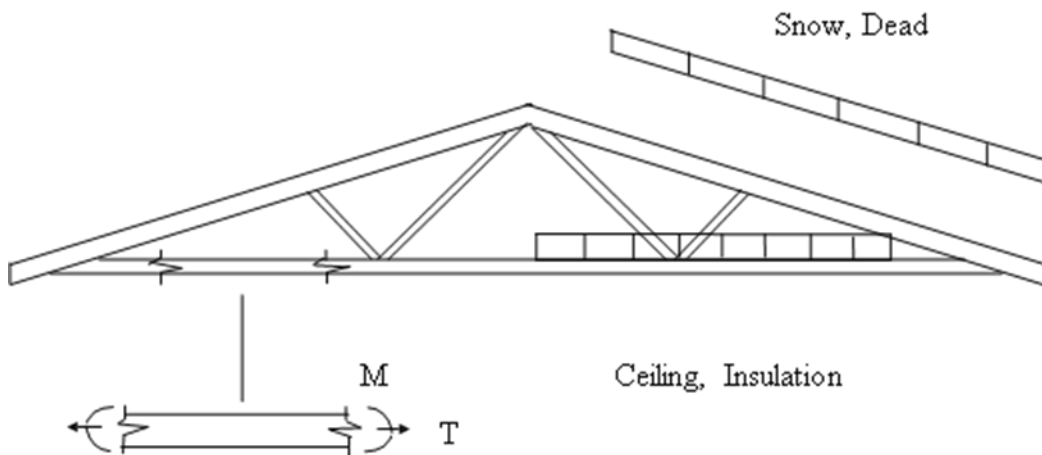

Member
Stresses: Axial Tension and Bending
Moment

- Formulas listed
- Simplest case:

$f_b/F_b + f_{t(c)}/F_{t(c)}$ less than or equal to 1.0

= actual member stress

F = allowable member stress

- This means that the sum of the percentage of actual bending tension (or compression) stress plus the percentage of actual axial tension (or compression) stress should be less than 100 percent of allowable tension (or compression) stress. That is, allowable stress equals the sum of the contributions from bending plus axial allowable stresses.

NDS Part IV Sawn Lumber

- Refers to design values given in NDS Supplement. Allowable stresses differ depending on single-vs-repetitive member use.
- Single member use
 - individual member responsible for carrying entire load
 - example: beam, column
 - no "near neighbors" to share load
- Repetitive member use
 - bending members only
 - spaced 24 inches on center or less
 - not less than 3 in number
 - joined by floor or roof decking to spread load to adjoining members
 - example: joists, rafters, trusses, built up beams, wall studs

NDS Part V Structural Glued Laminated Timber

(Also see further information in this commentary section.)

- General Design Values based on visual and machine stress rated methods given in Tables 5A, 5B, 5C and 5D of the NDS Supplement.
- Design values can be modified due to service condition, etc., similar to those specified in Part II.
- Curved glued laminated members (arches) are possible and special consideration is specified.
- Glued laminated members subject to compression or combined tension-compression are designed per Part III with some additional requirements.

NDS Part VI Round Timber Poles and Piles

- Rarely used for UDC construction.

321.02 (3)

- Specifies types of preservative treatment, typical dimensional requirements per American Wood Preservers Association (AWPA) and ASTM standards.
- Design values and modification factors based on service condition, size and condition of preservative treatment.

NDS Part VII Prefabricated Wood I-joists

- Load duration factor is applicable, as well as beam stability factor
- Repetitive member factor $C_r = 1.0$

NDS Part VIII Structural Composite Lumber

- New section for NDS 2001 and often used in UDC construction.
- Load duration factor is applicable, as well as beam stability factor
- Repetitive member factor $C_r = 1.04$ for 3 or more joined within 24"

NDS Part IX Wood Structural Panels

- New section for NDS 2001 and often used in UDC construction.
- Load duration factor is applicable
- References American Panel Association (APA) documents for plywood, oriented strand board (OSB) and composite panels for design and construction recommendations of structural assemblies consisting of panel products.

NDS Parts XI & XII Mechanical Connections & Dowel-type Fasteners

- Tables give design values, load per fastener, for:
 - nails (common, box, etc., with minimum diameters)
 - screws (lag, wood)
 - bolts
- Minimum penetration of a lag screw is four times its diameter
- Minimum penetration of a lag screw is four times its diameter
- Edge distances, end distances, and spacing of nails and spikes shall be sufficient to prevent splitting of the wood
- This information is used to develop the fastener table in UDC Appendix.

NDS Part XIII Split Ring and Shear Plate Connectors

- Tables give design values, load per fastener, for:
 - split rings
 - metal plates

NDS Part XIV Timber Rivets, Part XV Special Loading Conditions, and Part XVI Fire Design of Wood Members

- Not often used in UDC construction.

NDS Supplement: Design Values

- Depending upon species, grade, and size classification, design values are provided for various loading situations:

F_b - Allowable bending stress, psi

F_c - Allowable compressive stress (parallel to grain), psi

$F_{c\perp}$ - Allowable compressive stress (perpendicular to grain), psi F_t

- Allowable tension stress, psi

F_v - Allowable shear stress, psi E

- Modulus of Elasticity, psi

Note: See UDC Appendix for complete tables for selected species and values.

Overview Of Important Issues Regarding Trusses

1. Per s. SPS 321.02(3)(f) and Table 320.24-13

Trusses shall conform to ANSI/TPI 1-2007, "National Design Standard for Metal Plate Connected Wood Truss Construction."

2. Per s. SPS 320.09(5)(b) The designer may be required to submit plans showing the truss design is consistent with or shows:

- house framing plan
- bearing and connection/anchorage details
- design loads
 - top and bottom chord load
 - live, dead, wind load
 - concentrated or non-uniform loads
- outside configuration of components
- permanent bracing system if required
- connector plate size per joint

3. Per s. SPS 320.09(6)(a)

The designer may be required to submit data including:

- stress calculations (axial, bending, &/or combined)
- species, grade, size of members
- member forces
- reactions
- connector plate capacity required per joint

321.02 (3) Wood Roof Truss Attic Design Loads

The department has determined that the design minimum live load in Table 321.02 for ceilings with storage of 20 PSF applies to stick-built frame construction. Roof trusses designed in accordance with ANSI/TPI 1-2007 for attic storage loading will meet the intent of the code, only if such design criteria has been identified on the truss and drawings.

Additional Background Information for Glue Laminated Timber⁽¹⁾

321.02(3)(b)

1. Used for long spans, large loads and architectural effect.
2. Relatively thin laminations of wood combined to practically any length and size.

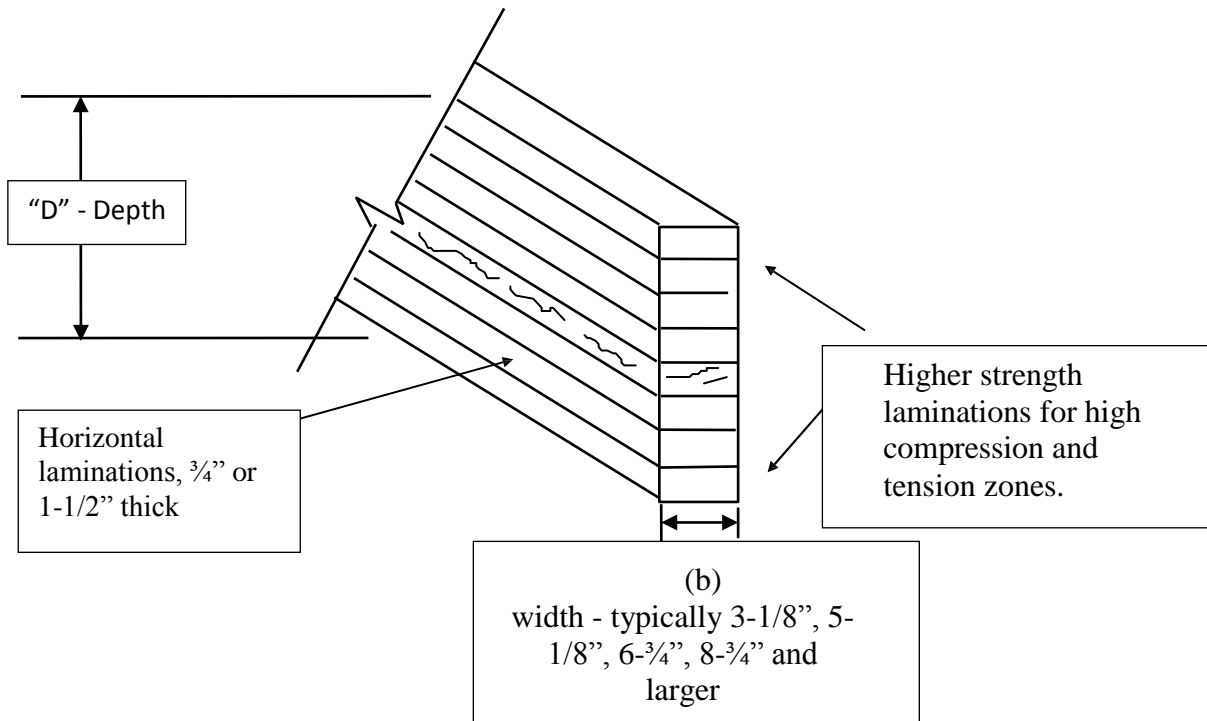

3. Relatively higher structural properties.
 - Laminations of high quality wood
 - Defects - Knots etc., spread out, not continuous for depth or width of member
 - Maximum 2600 psi bending stress = F_b , compared to 1900 psi for sawn lumber
4. Glue generally for wet use applications with some dry use glue allowed, but not common.
5. Graded differently than sawn lumber.
 - 24F indicates allowable bending stress = 2400 psi under normal conditions.
 - V1, V2 etc., refers to Visual Graded No. 1 or 2.
 - E1, E2 refers to Machine Grading by testing the Modulus of Elasticity.
6. Some condition of use and load duration adjustment factors may apply.
7. Design properties are included in the NDS Supplement.

(1) Source: Breyer, Donald E., *Design of Wood Structures*, McGraw Hill, 1980.

321.02(3)(b)1.b. Re-Used Graded Lumber

Sound, used lumber, with grade marks still identifiable, may be used for one- and two-family dwellings as follows:

The published NDS allowable design stresses for the lumber species and grade represent values for new lumber. To apply these to used lumber, these shall be reduced to a 90 percent value. NOTE: For joists and rafters, use " F_b " for repetitive- member use (multiplied by 1.25) and for normal load duration factor (LDF) conditions (multiplied by 1.0). These adjusted fiber bending values shall not be increased using LDF's for snow loading conditions. The span tables for joist and rafters in the appendix of the code may be used directly with the reduced design stresses with no further adjustments.

Used **re-sawn** graded lumber must be graded based on its re-sawn properties and certified in accordance with nationally recognized lumber grading rules for visually graded lumber per ASTM D245. Agencies publishing grading rules are listed in the NDS "Design Values for Wood Construction." Alternatively, the provisions of SPS 321.02(3)(b)3. may be used.

Sound lumber is defined as materials without structural damage such as splits, cracks, gouges, saw, rot or insect damage and with notching and borings limited as follows:

321.02(3)(b)3. Native Sawn Ungraded Lumber

Sound, native, sawn un-graded lumber may be used for one- and two-family dwellings per the NDS published allowable design stresses for the lumber species using No. 3 grade when used for studs, stair stringers, rafters or joists and No. 1 grade for beams, posts or timbers in lieu of certified graded lumbars. How may this section be applied?

Example #1:

1. I have an Eastern White Pine ungraded 2 X 4.. Can I use it as stud material?
2. Default Grade 3 can be applied to this lumber. In accordance with the lumber species and grade table in the UDC code appendix, grade number 3 has an F_b of 605 psi.
3. This F_b value is greater than the stud grade for the same species (570 psi) required by Table 321.25-A. Therefore, it is OK to use this for a stud.

Example #2:

1. I have an Eastern White Pine ungraded 2 X 10. Can I use this as floor framing material?
2. Default Grade 3 can be applied to this lumber. In accordance with the lumber species and grade table found in the UDC code appendix, grade number 3 has an F_b of 445 psi and a modulus of elasticity of 900,000 psi.

3. To determine the maximum permitted span for this lumber to be used as a floor joist, go to UDC code appendix Table F-2.
4. The maximum span for a 2 X 10 with a modulus of elasticity of 900,000 psi spaced at 12" on center is 14'-11".
5. Note, though, that the table minimum F_b for this member spaced at 12" o.c. is 777 psi.

321.02 (3)

This default Grade 3 lumber in question has an Fb of 445 psi. Therefore, this lumber may not be used without structural analysis that would typically show that a shorter span would work.

2007 Wisconsin Act 208 became law on April 22, 2008. This law permits individuals that saw their own lumber on site to “self-grade” their lumber. The person that does the self-grading must take a basic lumber grading program developed by the forest products outreach program at the UW-Stevens Point. Go to the website <http://www.legis.state.wi.us/2007/data/acts/07Act208.pdf> to get more information on this act.

An alternative for lumber species not listed in the NDS "Design Values for Wood Construction" and where nationally recognized allowable design stresses are not available, would be structural testing of the materials. Testing must be conducted by a recognized independent testing agency in accordance with the appropriate ASTM load test procedure. The cost of such testing shall be borne by the person applying for the building permit.

The department will accept lumber species design stresses recommended by the U.S. Forest Products Laboratory, Madison, Wisconsin.

321.02 (3) (g) Log Homes

This section addresses log home construction; however, log homes are often engineered and kit-produced by a manufacturer. In that case, their requirements should be followed when stricter than the code minimums. The UDC also adopts the log home construction standards in of ICC 400-2012 Log Structural Standard.

321.03(1) Acceptable First Floor Exits

Question: Is it acceptable to use a ground floor exit door to help satisfy the requirement for two exits from a first floor?

Answer: Yes, assuming the two floors are connected with a stairway and the other requirements are met. In this situation, the exit separation distance would be measured from the middle of the first floor exit door to the middle of the top of the stairway on the first floor.

Question: Are first floor bedrooms required to have egress windows?

Answer: No. The code indicates two exits are required from the first floor; however, if two exits do not serve the first floor or their separation requirements of 321.03(1)(e) are not met, then any first floor bedroom would require egress windows.

321.03(1)(e) Separation of Exits

Note that these sections generally require the two required exits to be separated a distance of at least one-third the longest diagonal measurement in plan view of that floor or at least 20 feet (see diagrams).

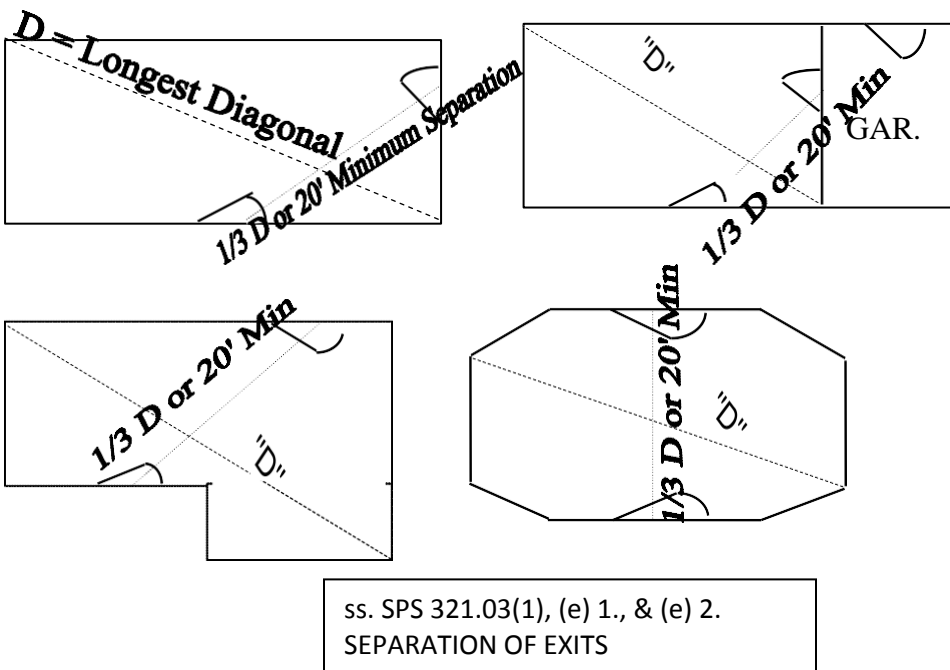

321.03(2) Second Floor Bedroom Egress

Question: If one of the second floor bedrooms has a code-compliant exit door out of the bedroom onto a deck or balcony, can the requirement for egress windows in the other second floor bedrooms be waived?

Answer: Yes, but only if the hardware on the bedroom door, which leads to the second exit is incapable of being locked from the hallway that serves as the exit path from these other bedrooms. See section 320.07 for 'EXIT' definition.

321.03(3) Acceptable Exits Above the Second Floor

Small third floor rooms specified under s. SPS 321.03 (3) (b) require only one stairway or ramp that leads to the second floor or lower in the dwelling. If the dwelling is fully sprinklered, only one exit is required from the third floor. Otherwise, only stairways or ramps to the second floor or grade are acceptable to meet the two exit requirements. If an exterior stair is used, access to it from the third floor shall be with a door and if the stairway terminates at the second floor, then there must be a door leading back into the dwelling or a code-compliant egress balcony to complete the exit path.

321.03(3) Exits from Attics

Question: Does the requirement for two exits for floors above the second floor apply to walk-up storage attics?

Answer: No - it would only apply to habitable spaces including offices, playrooms or other conditioned spaces [see s. SPS 322.10 (3)] that may be occupied. Since attics are not considered habitable spaces they need not have natural light and ventilation nor multiple electrical outlets or lights unless they are used for mechanical equipment or electrical equipment.

321.03(4)

321.03(4) Exits from Lofts

A code-complying loft is not subject to the exiting requirements of the other subsections of this section. In other words, a loft open to a first-floor or second-floor below, only requires a single stairway or ladder (depending on area) to satisfy exiting. A loft bedroom or loft level would not require an egress window but would require natural light and ventilation the same as any other habitable space. See s. SPS 320.07(50) of the code and this commentary for a discussion of what is considered "open to the floor below."

321.03(6) Bedroom Exit Windows

Question: Can egress windows be located in sitting or dressing areas of a master bedroom suite?

Answer: This section requires egress windows in some bedrooms. However, it does not specify the location of the window within the bedroom itself. A sitting room or area located in an alcove of a master bedroom is an acceptable location for the bedroom egress window. The alcove can be considered part of the bedroom if there are no doors obstructing communication between the two areas.

SPS 321.03 (6) Egress Window Dimensions

**Minimum
20" wide x 24" high
or
24" wide x 20" high**

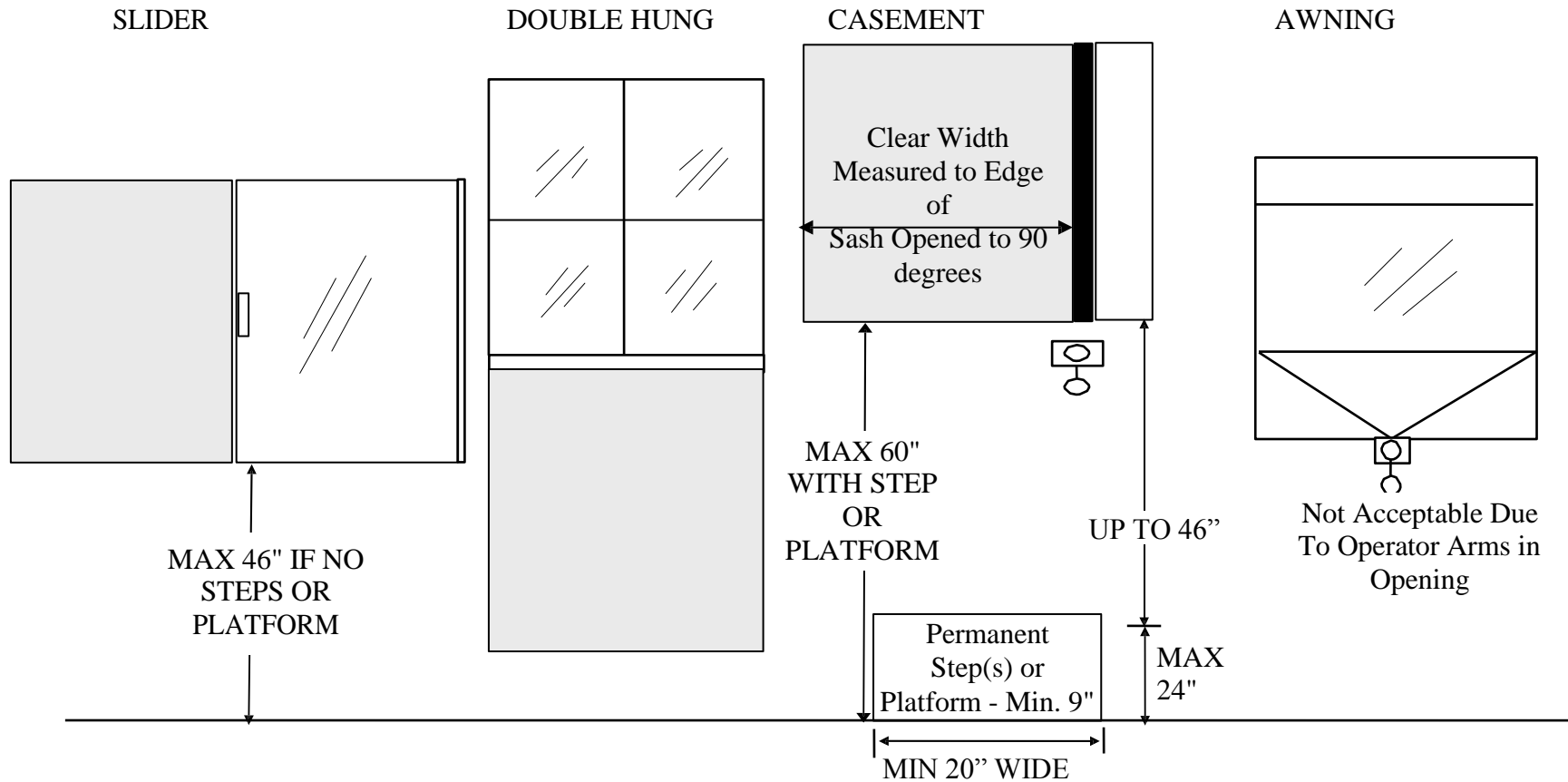

321.03(8) Balconies

Balconies not used for a required exit purposes may be greater than 15 feet above grade. All guards for balconies more than 24" above grade are required to comply with SPS 321.04(3) regarding height, in-fill or spindle and rail spacing requirements.

321.03(9) Split Level Dwellings

This section allows floor levels within 5 feet vertically of each other to be considered one floor level for exiting purposes. This does not change the definitions of the floor levels as set forth in s. SPS 320.07. Also the requirements of ss. SPS 321.03(1), 321.03(5)(b), and 321.03(6)(b) for proper separation of exits apply to the combined areas of the floor levels..

Also, any combined floor levels must all be within 5 feet of each other. In other words, a floor level that is between two other floor levels, separated by more than 5 feet, does not make all three levels into one even if exiting is from the middle level. However, the middle level may be combined with only one of the other levels.

321.035 Interior Circulation

Question: What is considered a full bath for this section?

Answer: The code is clear in requiring one full bathroom to be provided with a 2'-8" wide door. A full bathroom would contain a lavatory, water closet and bathtub or shower.

Question: What use is an "accessible" bathroom or bedroom with a 2'-8" door when it is on the second floor?

Answer: The intent of this section is to minimize future structural door framing alterations necessary to make a dwelling accessible to a physically handicapped resident. Obviously, further alterations would be necessary for the second floor situation, such as a stairway chair-lift or platform lift. Also, there may be temporary situations where a handicapped resident or guest, with physical assistance, could still make use of these second story rooms. "Accessible" does not always mean wheelchair-accessible.

Question: Are interior doors required to separate rooms such as bedrooms or bathrooms from the rest of the dwelling?

Answer: No, although it is common practice to have door separating these areas, doors are not required. The minimum opening requirements in SPS 321.03 (8) must be met but doors or privacy hardware are not code requirements.

Question: When these sections refer to a minimum door width of 2'-8", how is it measured?

Answer: The door itself should be measured - not the distance between jambs or stops.

321.035(3) Clearance Between Cabinets & Appliances

The required 30 inches of clearance between major appliances and islands, walls or built-in cabinets, is measured to the face of the cabinets, not including countertop nosings.

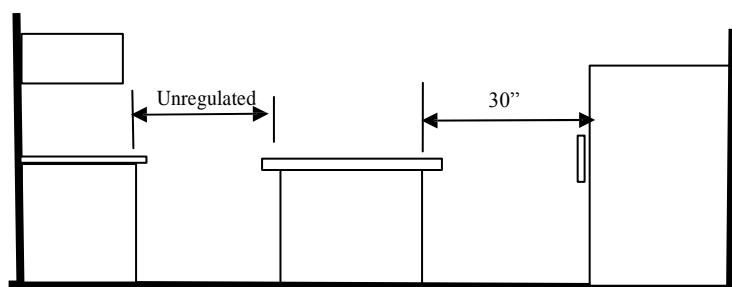

321.04(1) Non-required Stairs

Although stairways to attics and crawlspaces are not covered by the code, other non-required stairs, such as a second stairway from the first floor to a basement, are covered. Stairways are a major location of deaths and serious injuries in the home. Statistics from the U.S. Consumer Product Safety Commission (CPSC) show that one in four people will be injured and seek hospital treatment due to an injury related to stairways sometime in their lives. In 1994, the number of injuries from stairs, ramps, landings and floors was 1,879,029. This was an increase over the previous year by 11 percent (200,000-plus injuries), and was roughly equivalent to 19 percent of the total number of injuries reported in all categories for that same year.

The CPSC also estimates that the cost of home injuries in 1994 was \$94.3 billion. The cost directly related to injuries from stairs, ramps, landing and floors was \$17.5 billion.

Similarly, a study prepared for the U.S. National Bureau of Standards estimated that stair riser/tread dimensions are factors in nearly 50 percent of all stair-related injuries in the home.

321.04(1) Exterior Stairs

Question: This section applies to exterior stairs but how far away from the dwelling would this coverage extend?

Answer: The stair requirements would apply to any steps necessary to get an occupant free and clear of the dwelling and to grade, as stated in SPS 320.02(1)(g) Scope.

321.04(1)(a)2. Bathtub Platforms

Question: Do the stair code requirements apply to steps serving a bathtub platform? Answer: Yes, unless the stairs were manufactured as an integral part of the tub.

Where a step or steps are provided at a bathtub, whirlpool or hot tub, the steps are required to have a minimum 9-inch tread and maximum 8-inch riser. Where more than one step is provided, the steps need uniform risers and treads. The rim of the tub should not be considered a step unless it is a large area where occupants are likely to walk around the tub. Steps are not

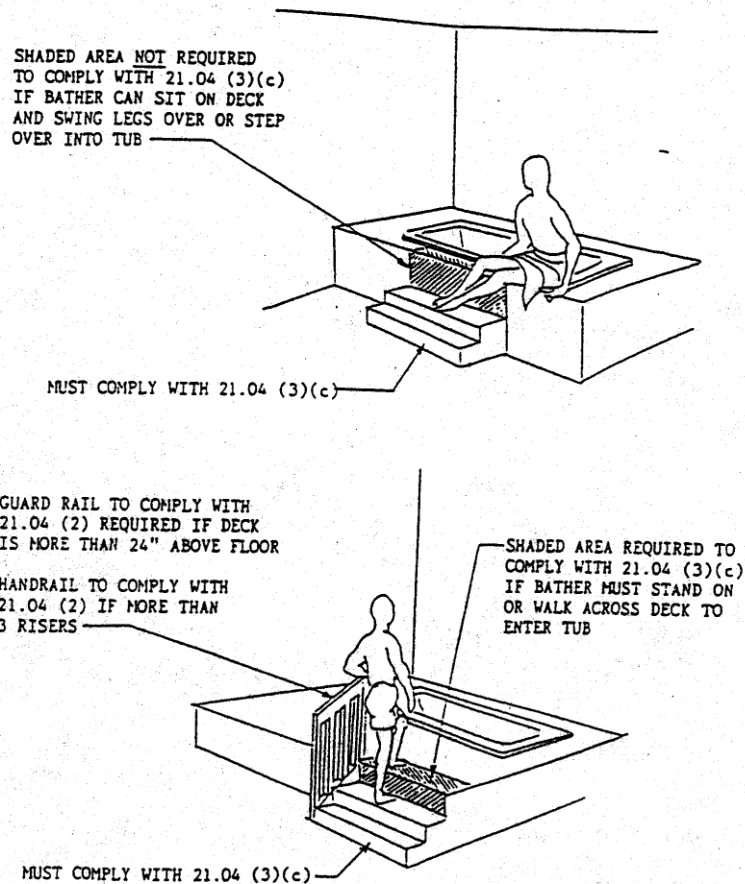

required to be provided at the base of a tub, but due to damp slippery conditions associated with tubs, steps that are provided shall comply with the code.

321.04(1)(b)2. Exterior Stairs to Basements

Question: Do bulkhead-type doors and stairways need to be code complying?

Answer: No, they must be code complying only if they are used AS AN EXIT, not if they are used as a service or non-required stairway. However, if they are required for egress, then verify the following items:

- landings,
- handrails,
- stairway width,
- headroom, and
- stair treads and risers.

In the case of bulkhead-type doors and stairs:

- The headroom height may be measured with the doors open, since the stairway is only usable if the doors are opened; and
- A landing is not required at the head of the stairway since this is considered an interior stairway protected from the weather. However, a landing is required at grade outside the door.

Regarding the door(s), they must meet the exit door requirements if this is a required exit. That means it must be a 32" wide leaf if there is a single door or two 30" openings if there are double doors. If this is not a required exit, then no minimum width applies. Door headroom, at the bottom of stairs, would have to be in compliance with the required stairway headroom.

321.04(2)(c)3.&4. Winder Steps

SINGLE WINDER

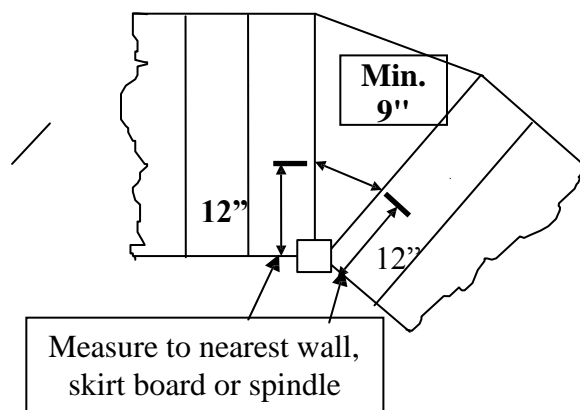

MULTIPLE WINDERS

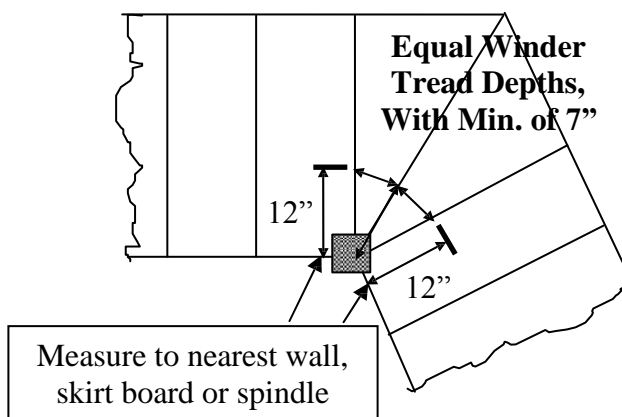

321.04(2)(d)3.&4. Planning for Stair Headroom

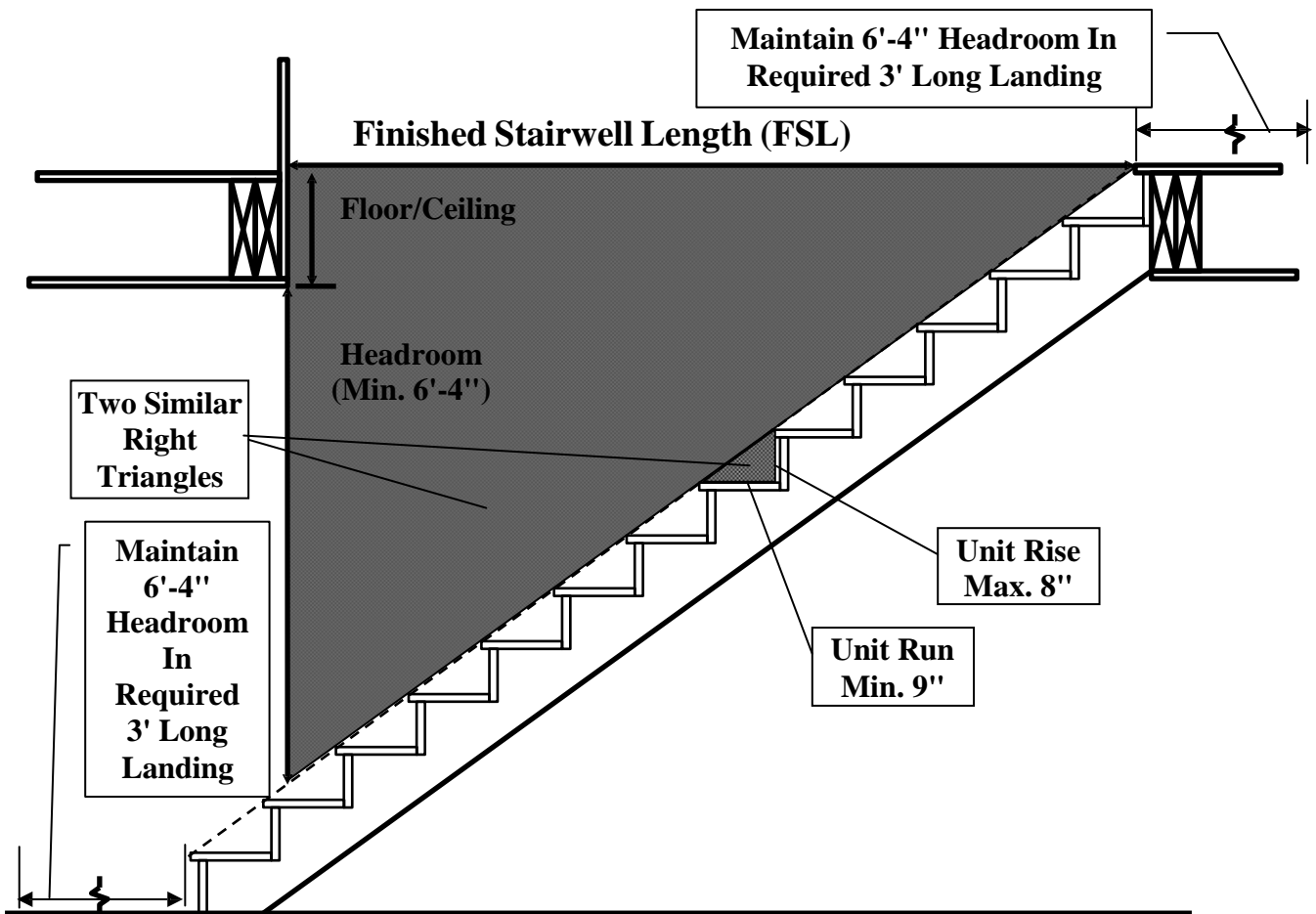

$$\frac{\text{Headroom} + \text{Floor/Ceiling Depth (HFCD)}}{\text{Unit Rise}} = \frac{\text{Finished Stairwell Length (FSL)}}{\text{Unit Run}}$$

So to solve for FSL,
$$\text{FSL} = \frac{\text{Unit Run} \times \text{HFCD}}{\text{Unit Rise}}$$

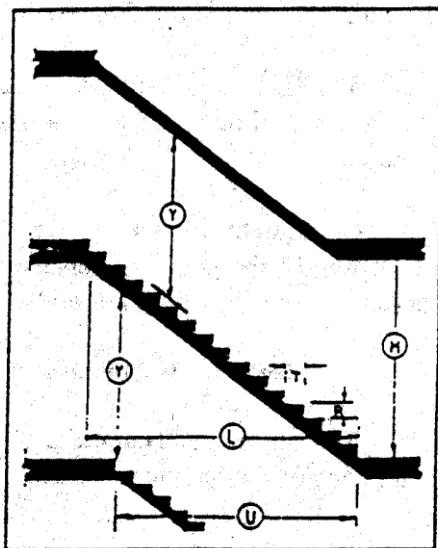

Straight Stairs						
Height Floor to Floor M	Number of Risers	Height of Risers R	Width of Treads T	Total Run L	Minimum Headroom Y	Well Opening U
8'0"	12	8"	9"	8'-3"	6'-4"	8'-1"
	13	7 3/8" +	9 1/2"	9'-6"	6'-4"	9'-2 1/2"
	13	7 3/8" +	10"	10'-0"	6'-4"	9'-8 1/2"
8'6"	13	7 7/8" -	9"	9'-0"	6'-4"	8'-3"
	14	7 5/16"	9 1/2"	10'-3 1/2"	6'-4"	9'-4"
	14	- 7 5/16" -	10"	10'-10"	6'-4"	9'-10"
9'0"	14	7 11/16"	9"	9'-9"	6'-4"	8'-5"
	15	-	9 1/2"	11'-1"	6'-4"	9'-6 1/2"
	15	7 3/16" + 7 3/16"	10"	11'-8"	6'-4"	9'-11 1/2"

321.04(2)(e)1. Tread Height and Depth Uniformity

Within a stairway flight, the greatest tread depth may not exceed the smallest tread depth by more than $\frac{3}{8}$ inch and the greatest riser height may not exceed the smallest riser height by more than $\frac{3}{8}$ inch. Once an intermediate landing occurs, a new flight starts and new riser and tread dimensions may be used.

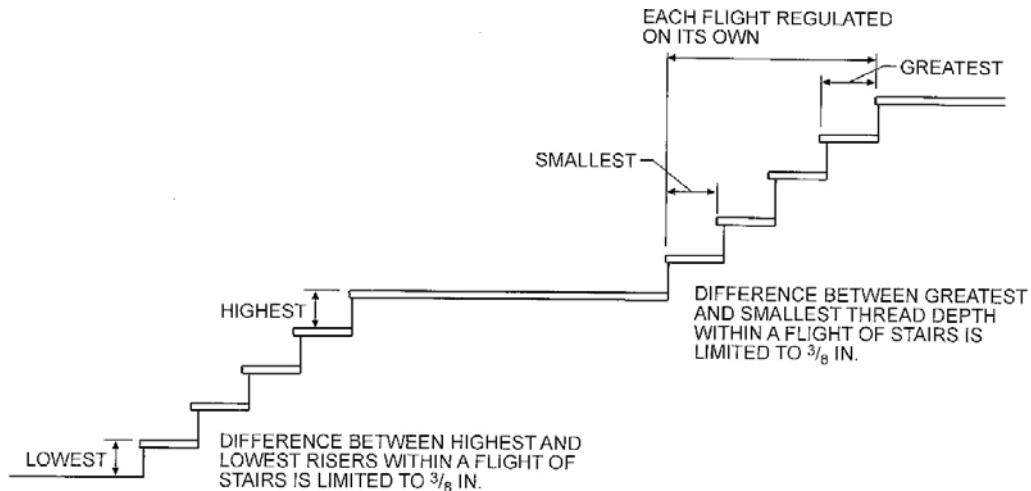

Question: How is tread and riser measured for the purposes of this requirement, especially taking into account the variety of finish materials used?

Answer: The tread and risers should be measured prior to application of carpeting. Measurements should be taken to hard surface finish materials. This alleviates problems encountered when the homeowner changes carpeting materials. If the carpeting is already in place, the inspector should estimate the thickness of carpeting and padding to determine compliance. The inspector should walk up and down the stairs, as well, to determine what, if any, tripping or falling hazard exists.

Question: At an exterior door (or an interior door, such as the 20-minute rated door, between the house and garage) a threshold separates the main floor level from the stair or landing, either up or down. Is the height of the threshold included in the riser height when you are determining if all risers are uniform?

Answer: No, you always measure from hard surface to hard surface. This means from the floor level to the landing or tread, even if the threshold “could” be stepped on, it is not included in the height of the riser. Remember that carpeting is not a hard surface even if is indoor/outdoor type material.

321.04(3) Handrails and Guards

See handrail cross-section diagrams in the UDC Appendix (approximately page 139).

Question: At the time of occupancy, a sliding patio door installed in an exterior wall is viewed by the inspector without an exterior deck, landing, stairway or platform. The floor to grade elevation difference is greater than 8 inches. Is this okay since

two other exit doors could provide exiting from the dwelling and the elevation difference is less than 24 inches?

Answer: No. The presence of the door, whether required or not, is installed to allow exiting and movement between areas. There is an elevation difference from the floor to grade in the exit path so a stairway or landing platform is required per s. SPS 321.04 prior to occupancy. However, if the door was substantially fastened closed with hardware and screws that would not allow it to be opened more than 4-3/8", then it would not be considered a door and steps would not be required in the interim until a proper exit path is provided.

Question: Does a non-required guard serving a porch less than 24 inches above grade need to comply with the code?

Answer: This section does not require the guard where the porch is less than 24 inches above exterior grade; therefore the height and other specifications are not required for the guard installed. The designer may still want to install the guard per code to alleviate concerns that the installation of a non-required guard meeting less than the minimum specifications may provide a false sense of safety for the building occupants.

321.04(3)(c) Measurement of Grade Differences for Guards

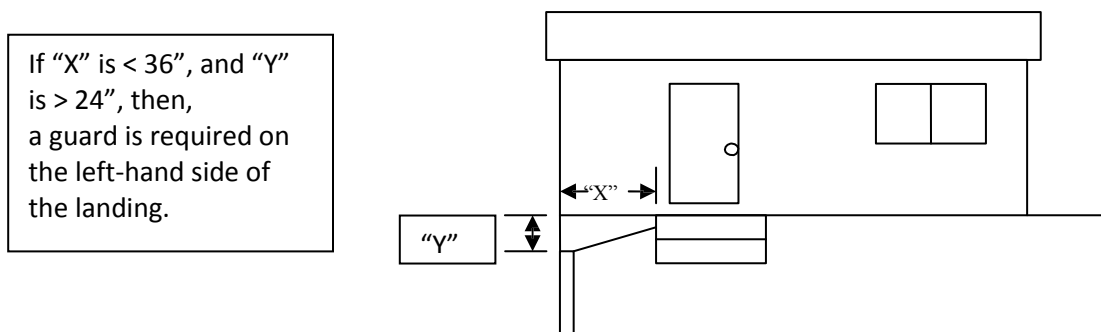

321.04(4)(a) Irregular Landings

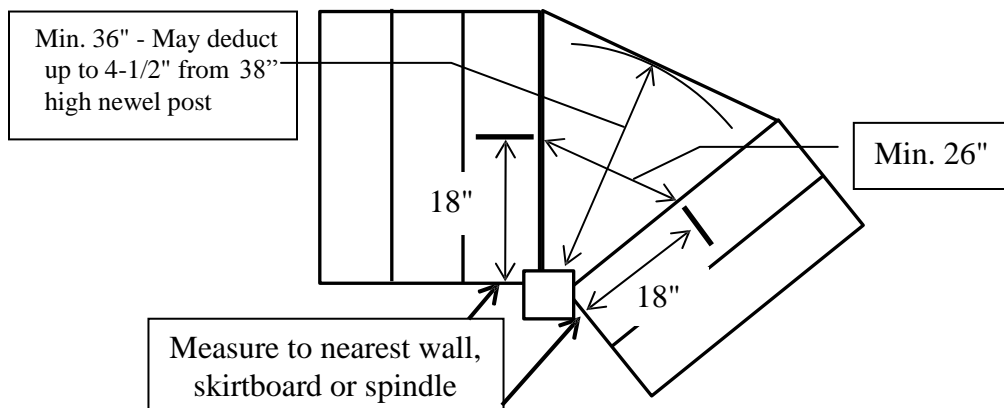

321.04(4)(a) Projections into Minimum Stair Landing Width

The 4 1/2-inch maximum allowed projection of handrails or trim into the width of a stairway on each side also applies to both sides of a landing since the landing is part of the stairway. Also see SPS 321.035(2)(b) regarding infringements permitted at hallways.

321.04(4)(d) Exterior Landings

This section would allow exterior landings at grade to be turf, gravel or other stable material as long as it sloped away from the dwelling.

General Requirement

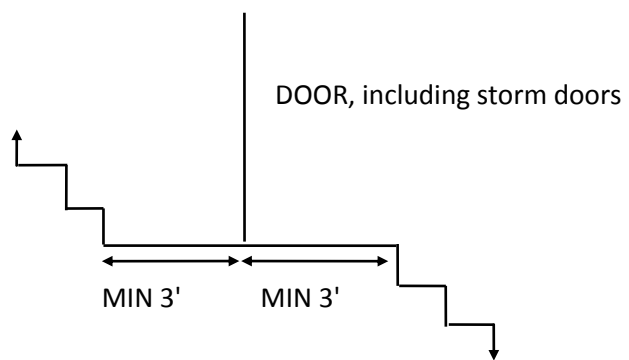

Exceptions

Interior Stairs (Garages and protected porches are interior spaces):

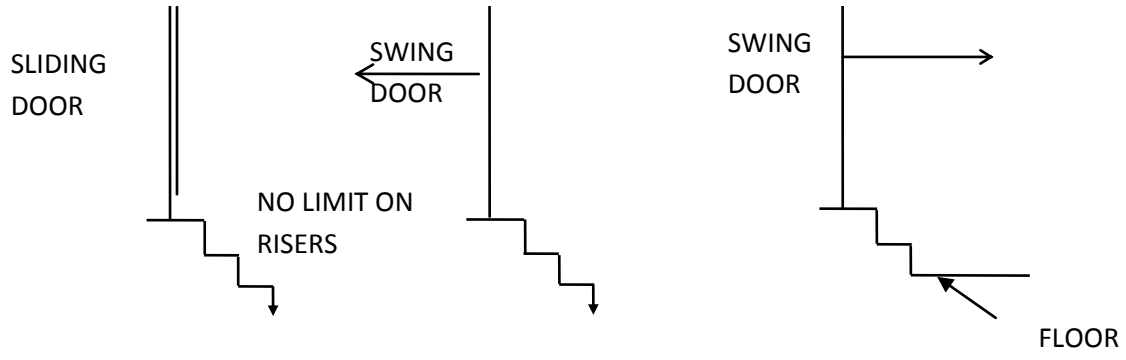

Exterior Stairs

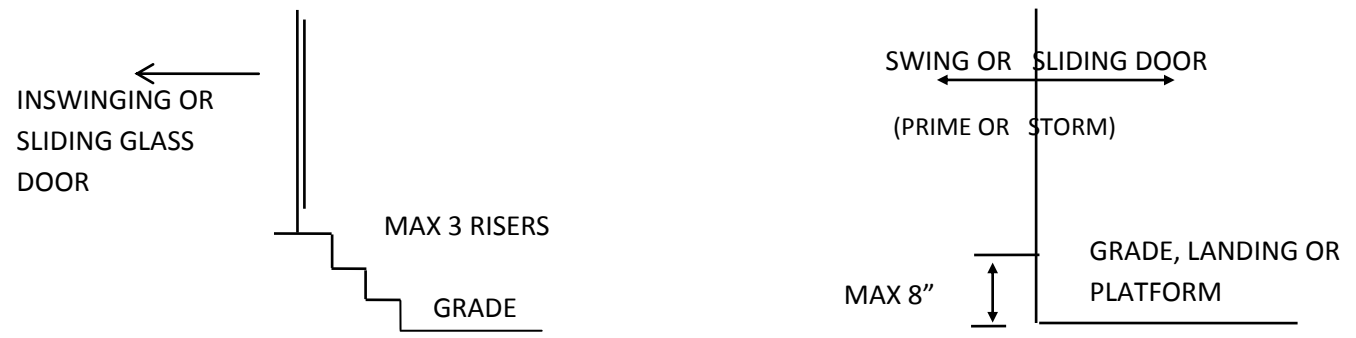

SPS 321.04(4) Landings at Doors

321.042(2) Ladder Treads

Ladder treads are measured the same as stairway treads - horizontally from nosing to nosing.

321.042(6) (b) Top Ladder Tread

This section is requiring that the top tread's (first tread below the floor level) back edge be at least 7 inches from the wall in front of it. This ensures adequate toe room and still allows a full depth tread.

321.05(3) Safety Glass

Safety glazing may now meet 16 CFR Part 1201 or ANSI Z97.1. It is important to note that state statutes s. 101.125 also requires safety glazing. In addition, the Federal Consumer Product Safety Commission (CPSC) in its regulation 16 CFR Part 1201 sets a minimum for safety glazing requirements for doors and tub & shower enclosures that states may only exceed with their requirements. While most of the items covered by these requirements are glazed in the factory, local inspectors may become involved when site- made doors are used, re-glazing is done, old doors are reused, sidelights are site-installed or when the manufacturer fails in its obligations. Following are some questions and answers on these various requirements.

Question: Why is safety glazing necessary?

Answer: The CPSC found that prior to its rules in 1974 that approximately 73,000 injuries related to architectural glazing were treated annually in hospitals nationwide. Almost half were under age 14. The worst accidents are those where the victim breaks the glass on impact and then he or she rebounds back. On the rebound, the shards of glass get caught under the skin and then severely rip it as the victim continues rebounding.

Question: How can I identify safety glass?

Answer: It will normally have a permanent label in the corner stating that the glass meets 16 CFR Part 1201. You may request documentation from the manufacturer if the label is not present. Safety glazing is classified by the manufacturer as either Category I for use only in doors where the glazing is less than 9 square feet or Category II for all the uses.

Question: What are the different types of glazing and which may be acceptable?

Answer: Tempered glass may be acceptable. It is produced by reheating glass and then suddenly cooling it. It is four times stronger than regular annealed glass. It cannot be cut after tempering so dealers will often need to custom order it from a tempering facility. It breaks into small pieces when broken.
Laminated glass may be acceptable. It consists of two or more layers of glass bonded to a tough resin interlayer. It can be cut or drilled.

Wired glass is generally not acceptable in areas where safety glazing is required unless it is labeled as meeting CPSC 16 CFR Part 1201. It would typically need an added layer of resin to meet that standard.

Heat-strengthened glass is not acceptable. It is produced similarly to tempered

glass but is cooled slower. As a result, it is only twice as strong as regular annealed glass. It can be cut or drilled.

Annealed glass is not acceptable. It is regular glass that may also be known as flat or primary glass. Also not acceptable are plate, float, sheet and patterned glass. These are easily cut and drilled.

Plastic glazing is not considered glass so it is not subject to the safety glazing requirements.

When safety glazing is required, all layers of a multi-layer assembly (e.g., insulated glass) must be safety glazed.

Meeting the safety glazing requirements would not necessarily meet the loading requirements for glass used in guards. Per SPS 321.04(3), guards shall meet a uniform loading of 50psf and a point load of 200 pounds at any point.

Question: Are these requirements retroactive?

Answer: While the UDC only applies to one- and two-family dwellings built since June 1, 1980, both the CPSC and state statutory requirements are retroactive to any re-glazing work done in all types and ages of structures.

Question: Can leaded, stained glass be used where safety glass is required?

Answer: Yes, based on the state statutes and CPSC regulations, this would be acceptable.

Question: Does the UDC require safety glass in panels or windows that come down near the floor but not next to a door?

Answer: No, although the Commercial Building Code, various model codes and good design would require safety glass in such situations, the UDC does not.

Question: Is safety glass required in overhead garage vehicle-passage doors?

Answer: No. The safety glazing requirement is for doors that are primarily used for human passage.

Question: Is safety glass required in skylights?

Answer: Not by the UDC or CPSC, although the Commercial Building Code requires its use in skylights. However, the 30 or 40 PSF snow load requirement of the UDC must be met.

Question: Are glass blocks or glass block windows used in a tub or shower area in compliance with the safety glazing rules?

Answer: Yes, first the individual units normally don't exceed the minimum dimensional requirements for safety glazed units. Secondly, the process used in the manufacturing of glass block puts them into the category of a masonry unit and therefore they do not need to meet the requirements for safety glazing.

321.05(3)(am)1. & (bm)3. Safety Glazing of Door Sidelights

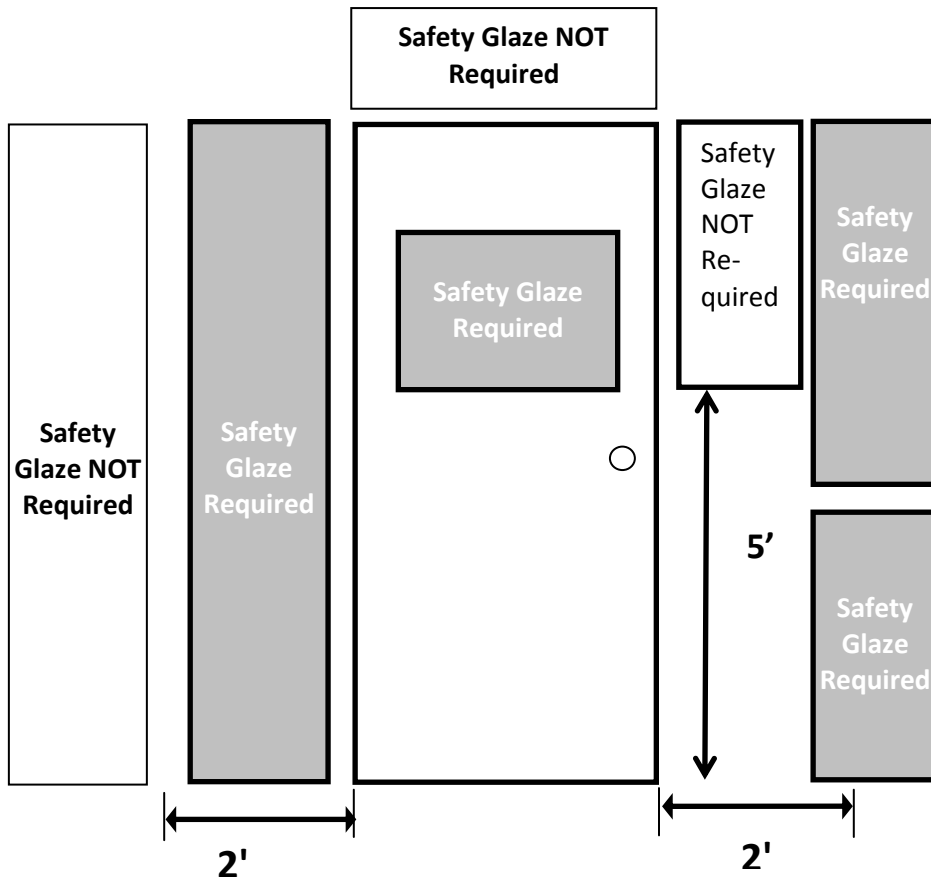

Exceptions – Plan Views

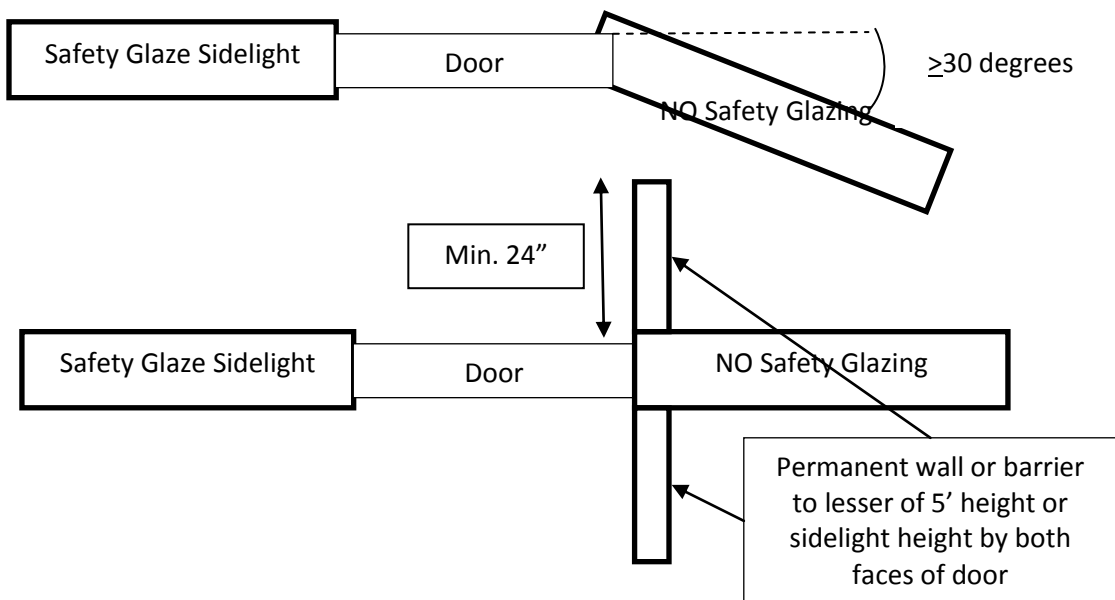

321.05(3)(b) Safety Glazing Around Tubs and Showers

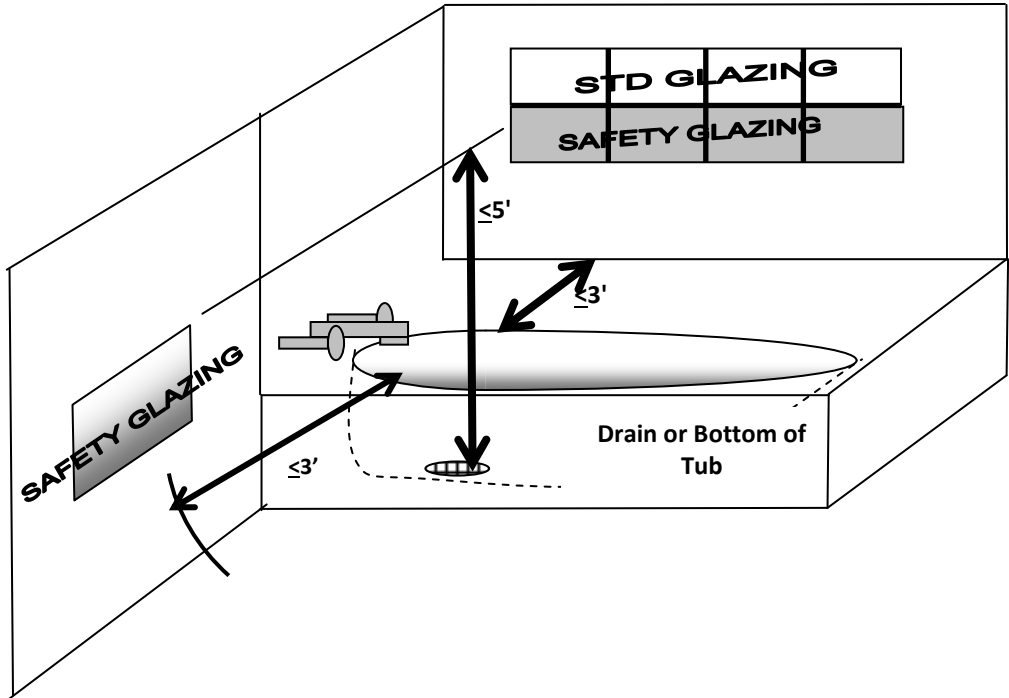

321.05(3)(am)3.&4. Safety Glass Around Stairs

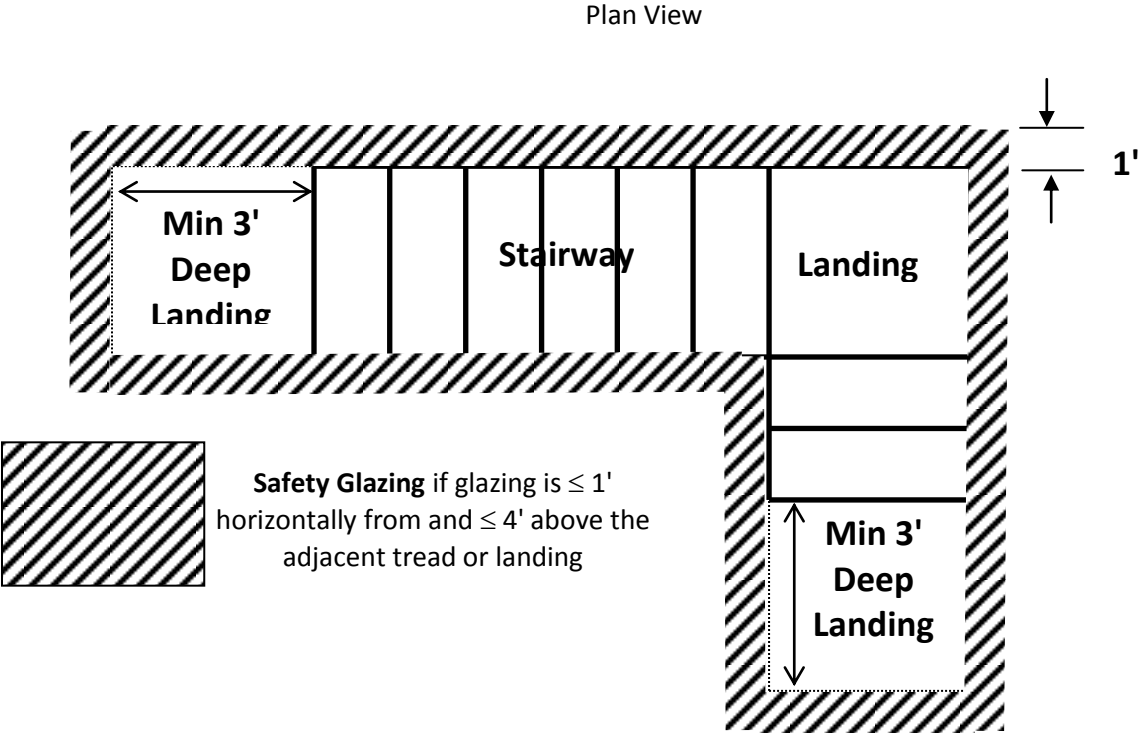

Question: Does a basement have to comply with the 7-foot minimum ceiling height requirement?

Answer: It only does in those ‘habitable’ areas of the basement that contain rooms used for sleeping, living, dining, kitchens, hallways, bathrooms and corridors. From a practical standpoint, most basements will contain some of these uses initially or after the basement is finished-off in the future. Some foresight by the builder or owner is advisable, since changing ceiling height is not a practical building alteration.

Question: May a ceiling fan or light fixture encroach on the required ceiling height?

Answer: A ceiling fan or light fixture may encroach similar to a beam or ductwork -no more than 8 inches below the required ceiling height; therefore, 6’-4” minimum clearance maintained between fan or other obstruction and the floor.

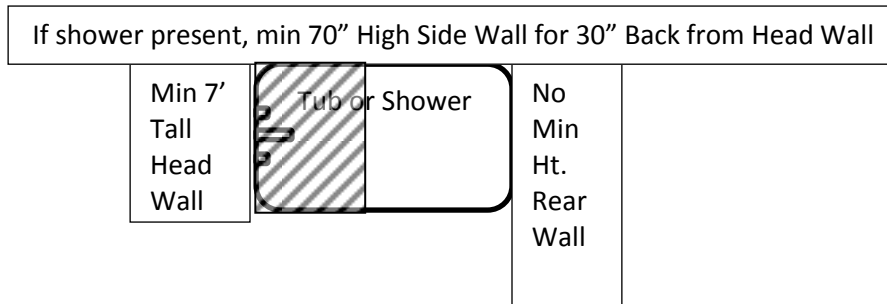
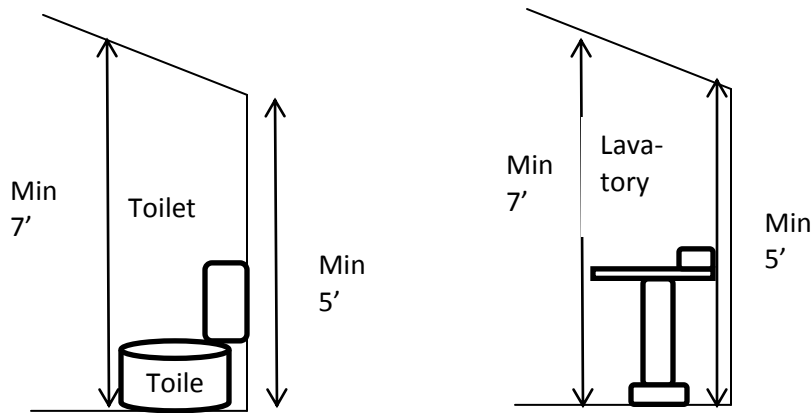

321.06 Minimum Ceiling Height Above Bathroom Fixtures
 (SPS 384.20(5)(L) of the WI Plumbing Code requires a minimum 30"x 70" clearance for showers)

321.07 Attic and Crawl Space Access

Question: Can access to an attic or crawl space be provided from outside the building, such as an outside vent or scuttle?

Answer: Yes.

321.08 Zero Lot Line Duplex Sometimes Identified as Twin Homes

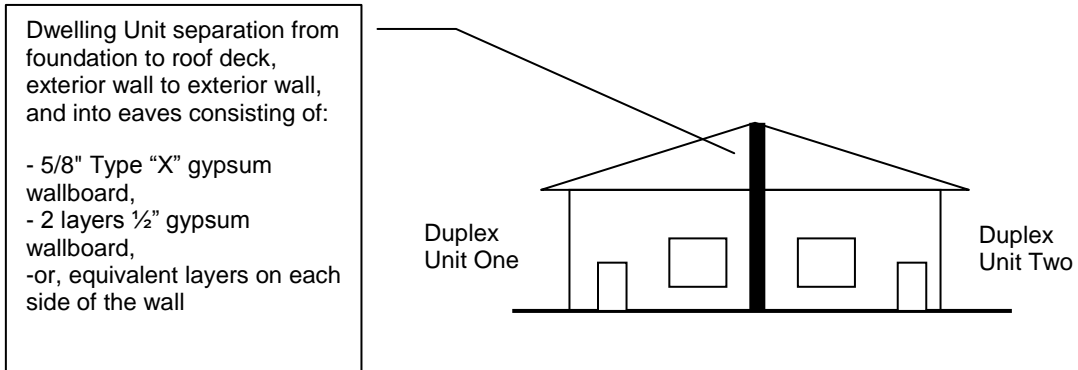

Unit Separation per Comm 21.08 (2) (d)
as referenced in Table 21.08

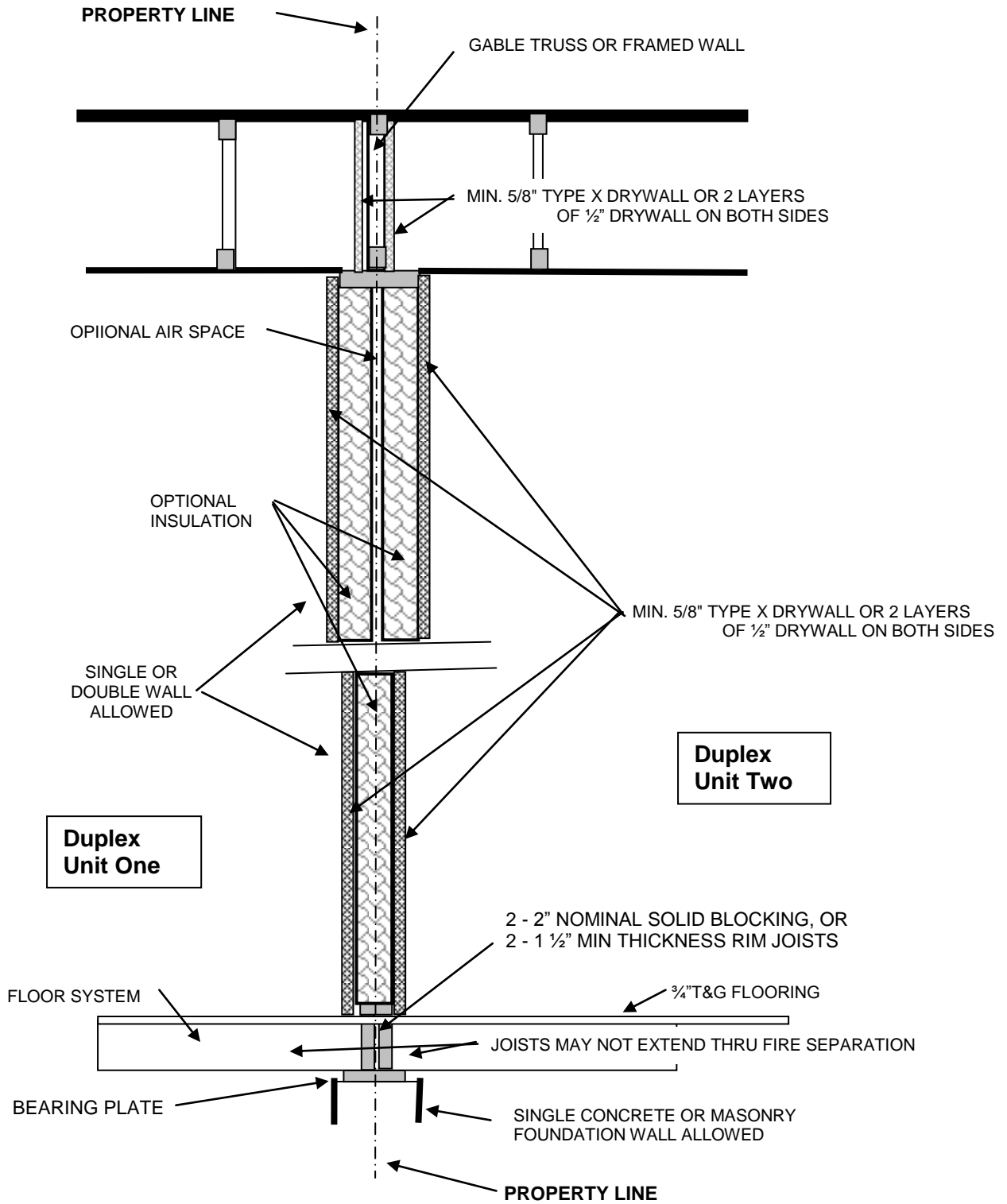

**Zero Lot Line Duplex
Separation Construction Detail**

321.08(1)(d)2. Attic and Crawl Space Access

Question: What kind of hardware is necessary on an attic access door that is located in the fire separation between a garage and dwelling area?

Answer: The cover or door shall be installed so that it is permanent (non-removable) with latching hardware to maintain it in a closed position. Self-closing hardware is not required.

321.08(1)(d)2. Attic and Crawl Space Access

Question: How do you measure the distances indicated in Table 321.08 regarding dwellings and attached/detached garages and accessory buildings?

Answer: Fire-rated construction may only be required in situations of a common house/garage wall or of adjoining house and garage walls that are less than 10 feet apart when measured perpendicularly from the house walls. The fire-rated construction is required only in those portions of either wall that meet the above test. In attached connecting breezeways or porches where there is no common wall but a common roof, the entire fire wall separation is required. This follows from the requirement that any fire separation shall extend from the top of the concrete or masonry foundation to the underside of the roof sheathing or ceiling. (See diagrams.)

ATTACHED GARAGES

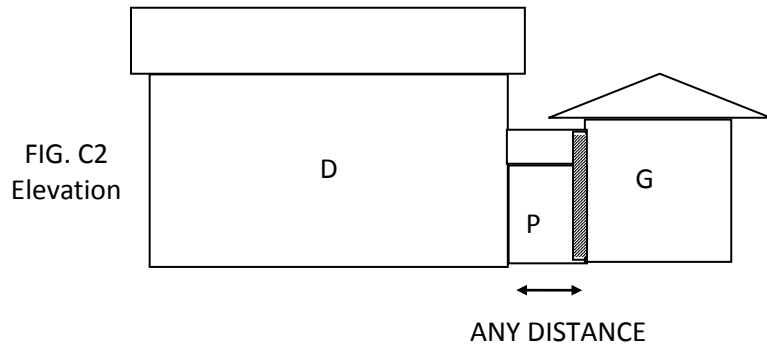
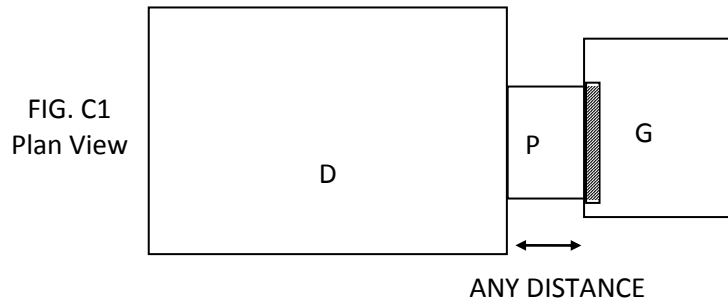
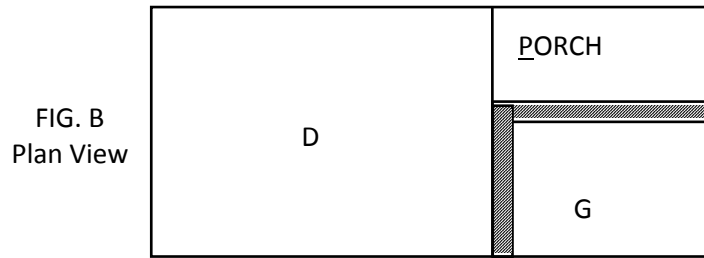
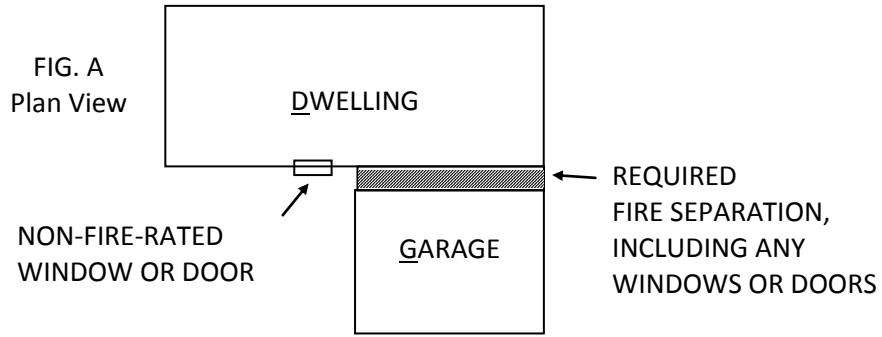

DETACHED GARAGE OR ACCESSORY BLDG

** Fire separation may be placed in either wall

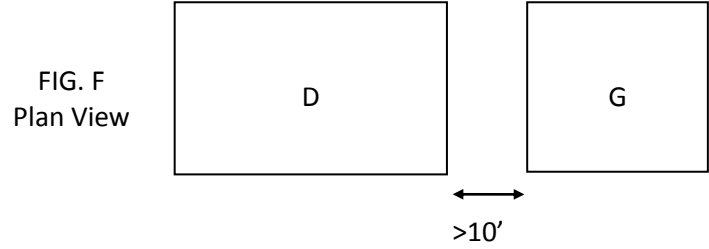
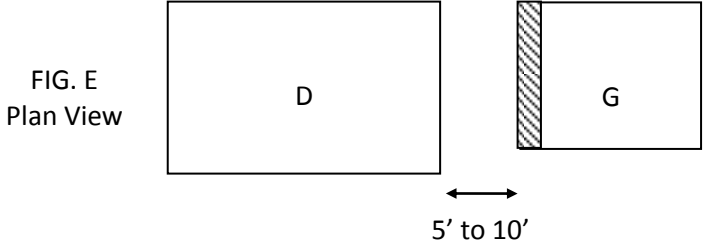
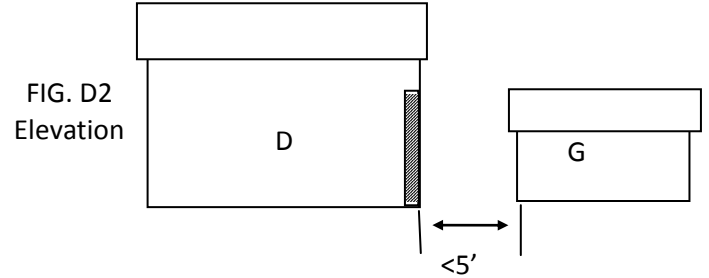
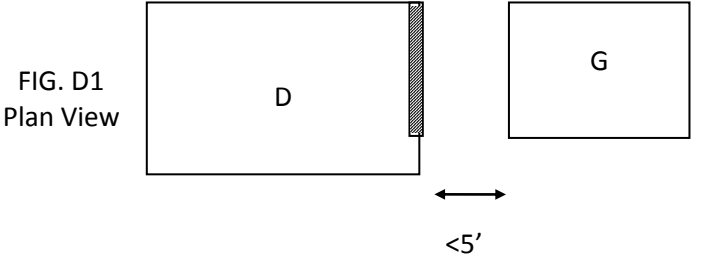

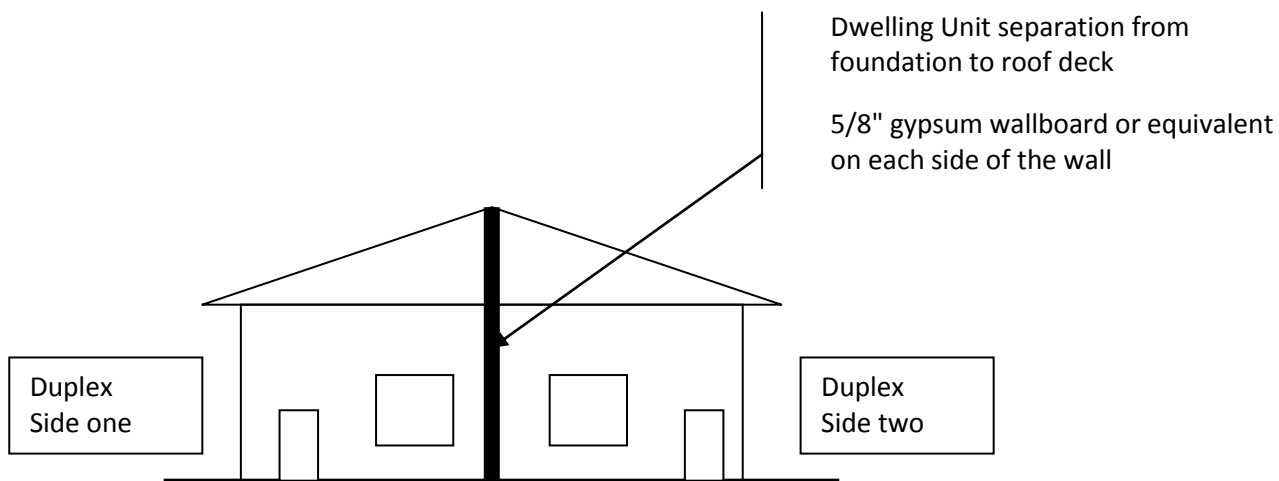

METHOD #1

Comm 21.08 (2) (b) 1.

Required for duplexes with property line at separation wall

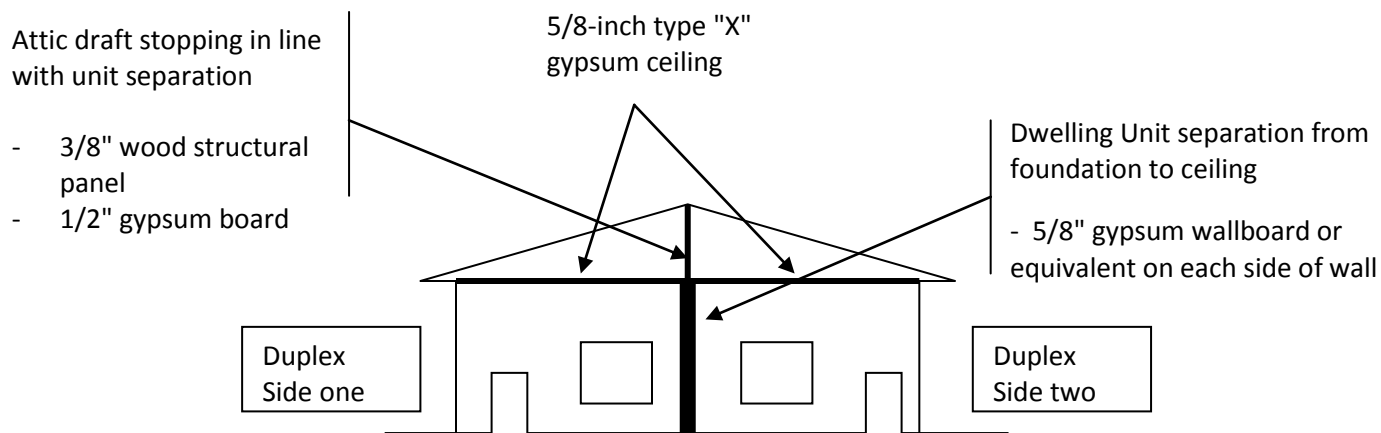

METHOD #2

Comm 21.08 (2) (b) 2

321.08 & 321.085 Fiberglass Insulation as Draftstopping & Fireblocking

Question: Is fiberglass insulation acceptable as a fireblocking and draftstopping material?

Answer: This section allows other noncombustible materials in lieu of the traditional 2 inch nominal wood or drywall firestops. Unfaced fiberglass batt insulation has passed the E-136 (ASTM) test for non-combustibility. Therefore, such insulation will be allowed as firestopping if it is tightly packed such that it will be held in place.

It may also be used as attic draftstopping if it securely supported, such as by chicken mesh on both sides of the insulation and attached to framing members.

321.085(1) Fireblocking

Question: How should tub/shower units be fireblocked?

Answer: For most units, there should be no need for fireblocking since interconnected vertical concealed spaces do not require fireblocking. However, if the unit has a canopy with a dropped soffit, then the fireblocking requirements would apply to the interconnected vertical and horizontal concealed spaces, similar to kitchen cabinet soffits. Also, the floor below a tub shall be fireblocked around plumbing penetrations if it allows air/fire passage between levels within concealed spaces.

At ceiling and floor levels in platform framing. The material used for this application is framing lumber.

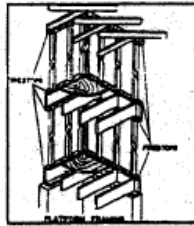

Firestopping needs to be installed below the dropped ceiling to prevent rapid movement into a large, open area. Material used is to be framing lumber.

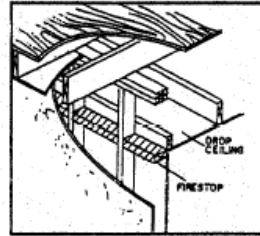

When remodeling an old house, beware of balloon framing. This framing technique is a fire hazard and must have firestops applied. The material used here is framing lumber. Balloon framed homes with cellulose insulation blown into the walls are much more firesafe than those with open cavities or more air permeable insulations.

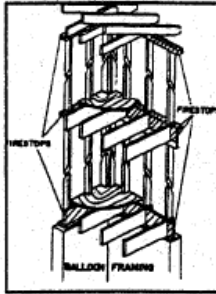

The two firestops applied to stair stringers are critical to the firestopping system and prevent the fire from moving quickly to the area between the floors. Material is to be boards, cement board, or plywood.

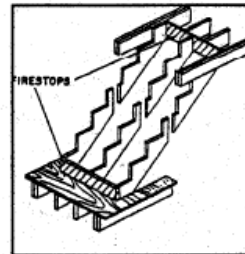

Firestopping at the soffit is critical to preventing a fire from rapidly moving into the open attic area. Material used is to be framing lumber.

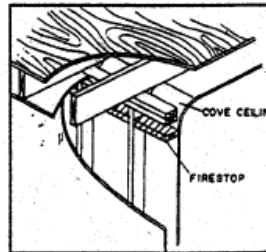
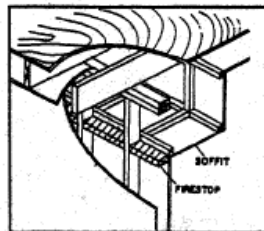

Cove ceilings provide a challenge because there is insufficient wood to stop the fire against the curvature of the ceiling. Firestops must be applied against the vertical portion of the wall. Material used is to be framing lumber.

321.08 Smoke Detectors

Question: If a contractor or owner wants to have additional smoke detectors over and above the minimum required by the Code, can they be battery-operated or must they be hard-wired into the electrical system?

Answer: If an owner wants a battery-operated smoke detector in every room or closet, they can do that.

Question: Should smoke detectors be connected to a separate, dedicated circuit or can they be tied to any lighting or outlet circuit?

Answer: Unlike fire alarm systems in commercial applications, the Department's recommendation is to connect the smoke detectors to a common lighting circuit and be connected ahead of any local switches. That way, if the circuit breaker trips, the owner will be aware that his smoke detector and alarms are not operational because his hallway or kitchen (etc.) lights aren't working.

321.10 Protection Against Decay and Termites

Although 321.10(5) does not specifically list framing connectors such as joist hangers to be protected against corrosion by treated lumber and exterior conditions, 321.02 Engineered Design requires that the manufacturer's requirements be followed when using engineered components. Typically treated wood manufacturers include requirements for connectors that are in contact with their products and wood connector manufacturers place limitations on the use of their connectors where subject to corrosion.

Question: An interior wood frame wall is placed on a continuous concrete footing in the basement and is used in place of a beam for support of the floor system above. The top of the footing will be level with the basement floor. Does the sole plate of this wall have to be pressure treated with a preservative or be decay-resistant lumber?

Answer: Subsection SPS 321.10 (2)(h) addresses this condition and would require treatment of the sole plate.

Information on AWPAs Use Categories for Various Service Conditions:

* Excerpt from AWPAs U1-11 Copyright 2011 AWPAs, All rights reserved

Use Category	Service Conditions	Typical Applications
UC1™	Interior construction Above Ground Dry	Interior construction and furnishings
UC2™	Interior construction Above Ground Damp	Interior construction
UC3B™	Exterior construction Above Ground Uncoated or poor water runoff	Decking, deck joists, railings, fence pickets, uncoated millwork
UC4A™	Ground Contact or Fresh Water Non-critical components	Fence, deck and guardrail posts, crossties & utility poles (low decay areas)
UC4B™	Ground Contact or Fresh Water Critical components or difficult replacement	Permanent wood foundations, building poles, horticultural posts, crossties & utility poles (high decay areas)

Information on AWPAs Listed Preservatives and Treatment Levels for Specified Use Categories:

Which wood preservative systems are listed in AWPAs Standards?

In today's marketplace, there are many wood preservative systems available to the public. It is important that those wood preservatives reviewed by AWPAs's Technical Committees and listed in AWPAs Standard U1 are selected at retentions that are appropriate for each Use Category. The following table is specific to Southern pine and Douglas-fir, but should be helpful in determining if the treated wood at your local retailer is treated with the correct preservative at the proper retention (expressed in pounds active ingredient per cubic foot of wood):

Code	Preservative Name	UC1, 2	UC3B	UC4A	UC4B
ACC	Acid Copper Chromate	0.25	0.25	0.50	---
ACQ	Alkaline Copper Quaternary (Type B or C)	0.25	0.25	0.40	0.60
ACQ	Alkaline Copper Quaternary (Type A or D)	0.15	0.15	0.40	0.60
ACZA	Ammoniacal Copper Zinc Arsenate	0.25	0.25	0.40	0.60
CA-B	Copper Azole, Type B	0.10	0.10	0.21	0.31
CA-C	Copper Azole, Type C	0.060	0.060	0.15	0.31
CuN-W	Waterborne Copper Naphthenate	0.070	0.070	0.11	---
CX-A	Copper HDO	0.206	0.206	---	---
EL2	DCOI-Imidicloprid-Stabilizer	0.019	0.019	---	---
PTI	Propiconazole-Tebuconazole-Imidicloprid	0.013	0.018	---	---
PTI	PTI plus Stabilizer	0.013	0.013	---	---
SBX	Inorganic Boron (Formosan termites)	0.28	---	---	---
SBX	Inorganic Boron (non-Formosan termites)	0.17	---	---	---

321.11 Foam Plastic Insulation Protection

Question: Does foam plastic sheathing located on the gable ends of an unoccupied attic have to be directly covered with a thermal barrier?

Answer: The foam plastic is required to be separated from the living space by a thermal barrier. In this case, if a thermal barrier is located on the ceiling, such as the interior gypsum drywall, the foam plastic is adequately separated from the living space and no direct protection is required.

Question: Does foam plastic placed on the interior of a crawlspace need to be covered?

Answer: If the crawlspace does not openly communicate with an adjacent basement or other living space, then the floor sheathing is adequate to separate the foam plastic from the rest of the dwelling. However, if the crawlspace adjoins a basement or other space so that there was free air flow between the two, then the foam must be covered.

Question: May foam plastic insulation be used on the interior of return air ducts?

Answer: Sections SPS 321.11 and 323.08 prohibit the placement of unprotected combustible foam plastic on the interior of supply and return air spaces. SPS 323.08(2)(a) requires ducts to be constructed of or lined with a noncombustible material. An exception is made for unlined wood joists or stud spaces. Therefore, combustible foam plastics located on the interior of duct spaces must be protected by a noncombustible 15-minute thermal barrier.

Question: Does foam insulation in attached garages need to be protected?

Answer: Yes, it does because the requirement applies to any space where occupants may be present or to which they may be indirectly exposed.

Subchapter III—Excavations

321.125 Erosion and Sediment Control

See the UDC Appendix for erosion control and storm water management information, including references to DNR & DOT websites for design standards. Also see Safety and Professional Services – Industry Services website for Soil Erosion program information, to get the latest information on design and requirements during and after dwelling construction.

Subchapter IV – Footings

321.15(2)(a) Unstable Soil

Forming of a continuous footing is required if you encounter an unstable soil. Per the note, an unstable soil would be one that cannot support itself at an approximately 90 degree angle for the full depth of the footing. Examples of unstable soils would be sands or gravels.

321.15(1)(e) Floating Slabs or Similar Shallow Foundations

SPS 321.15(1)(e) requires structures with frost foundations to be structurally isolated for the

entire building height from portions of the building structure constructed on floating slabs. This is needed so that portions that do not move will not separate from those that “float” under frost forces, as well as so that exits are not obstructed by relative movement of dwelling portions. A structural engineer could have some details that will work for the different types of materials used at these locations that need a different type of connector. Slip-joints can permit vertical deflection to occur, while maintaining horizontal load integrity of the structure. Load paths will be critical to determine what is acceptable there and what will not be permitted for connections.

321.15(2)(f) Deck Footings

Decks that are used in the required egress paths, even though physically separated from the dwelling, must comply with the UDC. Footings must be designed to carry the loads of the deck. They may be supported by frost footings or by a floating slab per SPS 321.15(2)(e). If the latter option is chosen, then care should be taken to avoid differential settlement or frost heave that could block the egress path. For the latter concern, a stepdown may be desirable.

Note that per the Appendix B deck requirements that if frost footings are provided for a deck, then any stairs of greater than 48” height are also required to have frost footings. Stairs of lesser heights may rest on grade blocks.

321.15(2)(a) Unstable Soil

Forming of a continuous footing is required if you encounter an unstable soil. Per the note, an unstable soil would be one that cannot support itself at an approximately 90 degree angle for the full depth of the footing. Examples of unstable soils would be sands or gravels.

321.15(2)(e) Floating Slabs

Section 321.16 generally requires a 48-inch footing depth to prevent frost damage. There are some exceptions to allow lesser footing depths provided measures are taken to prevent frost heave damage to the structure. Some measures which may be considered to help prevent damage, if over and above the code minimum requirements, include:

- Verification of good soils (well-drained, granular) which may be less subject to retaining water which may freeze and expand.
- Additional drainage at the affected footing in conjunction with good surface drainage.
- Providing reinforcement in the affected footing and/or foundation wall.
- Providing reinforced perimeter grade beams in slab-on-grade construction.
- Providing a mechanical tie or continuous reinforcement to bind the stoops or ramps to the foundation wall to resist relative movement. This would help prevent obstruction of exit doors or gaps at the wall to stoop interface.
- Overdesigning the foundation or structure to recognize the potential for some soil-caused deflection.
- Insulating the soil around the building perimeter with foam board laid horizontally just below the ground surface.

Most times a qualified engineer should make the determination which of the above, or other, measures is necessary for the situation or may be required to gain code compliance. The engineer's report should be submitted to the local inspector for approval.

321.15(2)(f) Deck Column Footing Size

Deck footings are required [s. 321.225(2)] to be designed with a bearing area equal or greater than the area required to transfer live and dead loads to the supporting soil without exceeding the bearing value of the soil. In lieu of a designed footing, the code required minimum size or a column footing of 24" x 24' x 12" thick should be used in accordance with SPS

321.15(2)(b). In designing a column footing for a deck, the following steps should be utilized:

- 1) Calculate the tributary area for floor and any roof area that the column carries.
- 2) Multiply the floor area by the code required live load and actual dead loads. Do the same for any roof area.
- 3) Divide the total load from 2) by the this site's allowable soil bearing value listed in the Table at the end of s. SPS 321.15(3) to find the minimum footing size in square feet.
- 4) To provide adequate spread of the load from the column above through the concrete or gravel footer to the soil, its thickness should be at least one-half of its diameter, but in no case less than 8".

Note that Appendices B and C of the UDC provides calculated deck footing sizes based on tributary area and soil bearing capacities.

321.16 Frost Penetration

Although this section lists landings and stoops as requiring frost depth footings, sections 321.15(1)(e) and (2)(e) & (f) would allow proper designed and isolated floating footings to be used for such elements, especially if of limited size.

Question: How does one determine if the local frost penetration is greater than the 48-inch minimum requirement by code?

Answer: In most cases, you will find that the average frost depth does not exceed the 48-inch depth. A good source for the average local conditions of frost is to check with the people involved with the installation of utilities or grave digging.

321.16(2)(a) Frost Protected Shallow Foundations

Question: Are frost-protected footings allowed and what standards must be followed in the construction of footings or slabs-on-grade without going below frost levels?

Answer: Yes. Frost-protected footings are allowed and by SPS 321.16(2)(a) are to be designed to ASCE-32-01 standard adopted with 2009 code changes. Frost-protected footings (FPF) are an internationally recognized and accepted technique of protecting slab-on-grade foundations of heated buildings against frost action. The FPFs use rigid horizontal perimeter insulation to reduce heat loss from the ground to the atmosphere around the dwelling. This heat keeps the ground from freezing and causing frost action on the structure. The FPFs have been used in Scandinavian countries since the 1950s and more recently in the United States. See the UDC Appendix for a public domain version of this design

methodology. Note that if the heated building design option is chosen, the current and future owners need be made aware of the need to keep the dwelling heated in the winter to avoid frost damage.

321.17 Determination of Drain Tile Need

Where municipalities exercise jurisdiction over requiring drain tile within their community, they should provide sufficient notice to the building permit applicant by indicating to the applicant at the time that the plans are approved how the municipality handles enforcement of drain tile. This means that the municipality, plan reviewer, or inspector should at the time the plans are approved indicate whether or not the community will 1) require drain tile to be provided per SPS 321.17, 2) not require drain tile to be provided, or 3) will make a determination as to whether or not drain tile will be required upon an inspection visit to the excavated site. This allows the communities to either have a blanket policy of a requirement or non-requirement for drain tile, and still allows them the flexibility to make that determination upon viewing the excavation, wherein they can determine soil types and sometimes water elevation. It is the department's position that for the drain tile requirement, the decision should be made as early on in the permit, plan review, inspection process as possible and that decision should be documented in review comments or inspection reports.

In response to questions and concerns regarding work continuing after an inspection has not been carried out after the 2-days after date of notification requirement, municipalities and inspectors should inform the builder or owner that they are proceeding at their own risk, and at the time the municipality or inspector makes the inspection they may still require the drain tile to be provided in accordance with SPS 321.17.

A municipality may use various criteria other than a soil test report (per s. SPS 321.17(1)(b) to determine where drain tile systems are required. Such criteria may include county soil maps, direct observation of standing water in the excavation, and experience with other sites in the locality. There is substantial discretion given to the local inspector. It is recommended that the criteria for this local discretion, or municipal policy, be uniformly applied within the municipality and expressed to builders before construction, such as at permit issuance.

Where no local permit is required for an addition, the code requires the owner and builder to install drain tiles where a soil test indicates periodic or seasonal groundwater at the footing. Often times such homes are also in un-sewered areas. The soil test report for a private sewage system will indicate depth to seasonal groundwater. This report may be used to determine dwelling drain tile requirements if the house site is close to and is similar in soil and drainage characteristics to the private sewage system on that site.

If a private sewage system soils report is not available or applicable, then the owner or builder may retain a qualified soils consultant (engineer, certified soil tester) to determine groundwater depth or rely on the experience of other projects in the area, if relevant.

TABLE 1
TYPES OF SOILS AND THEIR DESIGN PROPERTIES

Soil Group	Unified Soil Classification System Symbol	Soil Description	Allowable Bearing in Pounds Per Square Foot with Medium Compaction or Stiffness⁴	Drainage Characteristics²	Front Heave Potential	Volume Change Potential Expansion
Group I Excellent	GW	Well-graded gravels, gravel sand mixtures, little or no fines.	8000	Good	Low	Low
Group I Excellent	GP	Poorly-graded gravels or gravel sand mixtures, little or no fines.	8000	Good	Low	Low
Group I Excellent	SW	Well-graded sands, gravelly sands, little or no fines.	6000	Good	Low	Low
Group I Excellent	SP	Poorly-graded sands or gravelly sands, little or no fines.	5000	Good	Low	Low
Group I Excellent	GM	Silty gravels, gravel-sand-silt mixtures.	4000	Good	Medium	Low
Group I Excellent	SM	Silty sand, sand-silt mixtures.	4000	Good	Medium	Low

Soil Group	Unified Soil Classification System Symbol	Soil Description	Allowable Bearing in Pounds Per Square Foot with Medium Compaction or Stiffness⁴	Drainage Characteristics²	Front Heave Potential	Volume Change Potential Expansion
Group II Fair to Good	GC	Clayey gravels, gravel-sand-clay mixtures.	4000	Medium	Medium	Low
Group II Fair to Good	SC	Clayey sands, sand-clay mixtures.	4000	Medium	medium	Low
Group II Fair to Good	ML	Inorganic silts and very fine sands, rock flour, silty or clayey fine sands or clayey silts with slight plasticity.	2000	Medium	High	Low
Group II Fair to Good	CL	Inorganic clays of low to medium plasticity, gravelly clays, sand clays, silty clays, lean	2000	Medium	Medium	Medium ¹ to Low
Group III Poor	CH	Inorganic clays of high plasticity, fat clays	2000	Poor	Medium	High ¹

Soil Group	Unified Soil Classification System Symbol	Soil Description	Allowable Bearing in Pounds Per Square Foot with Medium Compaction or Stiffness⁴	Drainage Characteristics²	Front Heave Potential	Volume Change Potential Expansion
Group III Poor	MH	Inorganic silts, micaceous or distomaceous fine sandy or silty soils, elastic silts.	2000	Poor	High	High
Group IV Unsatisfactory	OL	Organic silts and organic silty clays of low plasticity.	400	Poor	Medium	Medium
Group IV Unsatisfactory	OH	Organic clays of medium to high plasticity, organic silts.	-0-	Unsatisfactory	Medium	High
Group IV Unsatisfactory	P _t	Peat and other highly organic soils.	-0-	Unsatisfactory	Medium	High

¹ Dangerous expansion might occur if these two soil types are dry but subject to future wetting.

² The percolation rate for good drainage is over 4 inches per hour, medium drainage is 2 to 4 inches per hour, and poor is less than 2 inches per hour.

³ Building code allowable bearing values may differ from those tabulated.

⁴ Allowable bearing value may be increased 25 percent for very compact, coarse grained gravelly or sandy soils or very stiff fine-grained clayey or silty soils. Allowable bearing value shall be decreased 25 percent for loose, coarse-grained gravelly or sandy soils, or soft, fine-grained clayey or silty soils. To determine compactness or stiffness to estimate allowable bearing capacity, measure the number of blows required to drive a 2-inch outside diameter, 1.375-inch inside diameter split-barrel sampler 1 foot

into the soil by dropping a 140-pound hammer through a distance of 30 inches.

Question: If a drain tile “sock” is used, can I eliminate some or all of the coarse aggregate around the drain tile?

Answer: No, the tile “sock” doesn’t replace any of the coarse aggregates function and therefore, if used, is only an added safe guard against fines clogging the tile weeps. With some types of soils the “sock” actually will hold certain types of fines and can cause basement water problems, so it is not recommended to use this type of ‘socked’ tile within those soil types having those fines.

321.17 Drain Tile Materials and Installation Requirements

A properly functioning drain tile system will lower the water table (seasonal or longer term) to the level of the tile installation in the immediate vicinity of the foundation wall.

This is important not only to achieve a relatively dry basement, but to maintain the structural integrity of the home. A saturated soil is not only heavier than dry soil, but it also has less internal soil friction that normally helps restrain lateral soil flow. Therefore, the potential lateral pressures exhibited by saturated soils are significantly greater than well-drained foundation backfill. Also a well-drained soil is less likely to frost heave when frozen.

The tile, backfill, and discharge systems are designed to maximize drainage and minimize potential siltation and overload of the system. A well-graded gravel bed and porous backfill are important for proper drain system operation. Also, per s. SPS 321.12, the grade around the dwelling shall slope away to minimize the need for the drain tile to handle surface water surcharge.

This office has received some complaints about sump pump systems operating continuously. Contrary to the complainants' concerns, this is usually evidence of a properly functioning system. The real problem is that groundwater in the area is at a relatively shallow depth, local soils are porous, or both. This results in a high volume of flow. These are conditions that should have been considered in making the decision where to site the building by the owner and builder.

Such situations normally occur in lowland areas, where water tables are perched above poor drainage strata, where surface drainage is bad, or where soils are very porous (fractured limestone, gravels, some sands) that allow easy lateral soil water movement. Zoning laws and subdivision ordinances more appropriately regulate whether certain parcels of land should be developed and what floor elevation is required given these conditions. However, zoning codes may not further regulate construction of the foundation drainage systems.

Care should be taken not to allow sump discharge to cause erosion which would result in sediment being deposited off site.

Wisconsin Plumbing Code in SPS 382.36(8)&(4) should be referenced in design of sumps and discharge to surface where a storm sewer is not available.

The bleeders do not need to be connected to the interior and exterior drain tiles with connectors – they may be butted to the tiles and have piece of membrane material, such as building felt, placed over the gap to kept foreign material out.

Per SPS 321.17(3)(d)1.b., where there is a stepdown in the footing, as at a walkout basement condition, drain tile is only required at the interior of the basement.

Subchapter V—Foundations

321.18(1) Foundation Wall Lateral Support

Question: Why is lateral restraint required for foundation walls?

Answer: All of the UDC concrete and masonry foundation wall tables are based upon the assumption of lateral support at both the base and top of the walls. (Note that an adequate connection is also required by s. 321.25(8) between the above grade wall and foundation wall to resist wind loads.)

The base of the wall typically is restrained by the floor slab or by the footing with a keyed joint or rebar. The top edge of the foundation wall may be restrained by the first floor through mechanical fastening. (Ledger blocking alone would not satisfy the dwelling anchorage requirement of s. 321.02(1)) and wall bracing requirements of s. 321.25(8).

Section 321.18(1)(c)&(d)2.a. requires that lateral restraint be continuous from the foundation wall to the plate to the restraining floor system. This will normally require that solid bridging or blocking be installed between the rim joist and adjacent floor joist that run parallel to the foundation wall in order to transfer the lateral loads on the foundation wall.

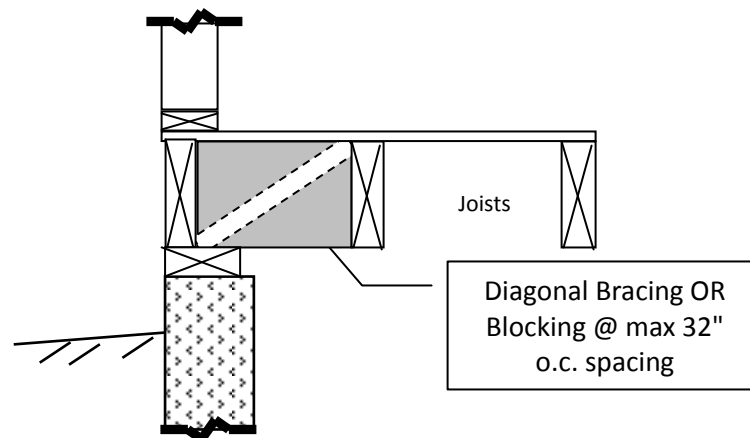

A special case arises where the fill around a foundation is uneven, as in a walkout basement. In this case the soil pressure on either side of the house is not balanced, thereby possibly causing lateral racking movement of the foundation and floor system. To resist this, additional lateral support by rigid (plywood

sheathed) interior cross walls or by pilasters may be needed.

This section requires the top of the foundation wall to have adequate lateral bracing to the floor above to resist lateral soil loads, as through anchor bolts or other means. Where failures of foundations walls have occurred in the past, investigation has shown that many times damage could be attributed to lack of lateral support at the top of the walls rather than to faulty material or workmanship. In other cases, the use of a weak mortar in the masonry walls was an important contributing factor. The practice of some contractors backfilling basement walls before the first floor lateral support system is in place contribute to failures.

FOUNDATION LATERAL RESTRAINT

In addition to bolts, other means such as straps or engineered connections may be used to provide lateral restraint to the top of the foundation wall.

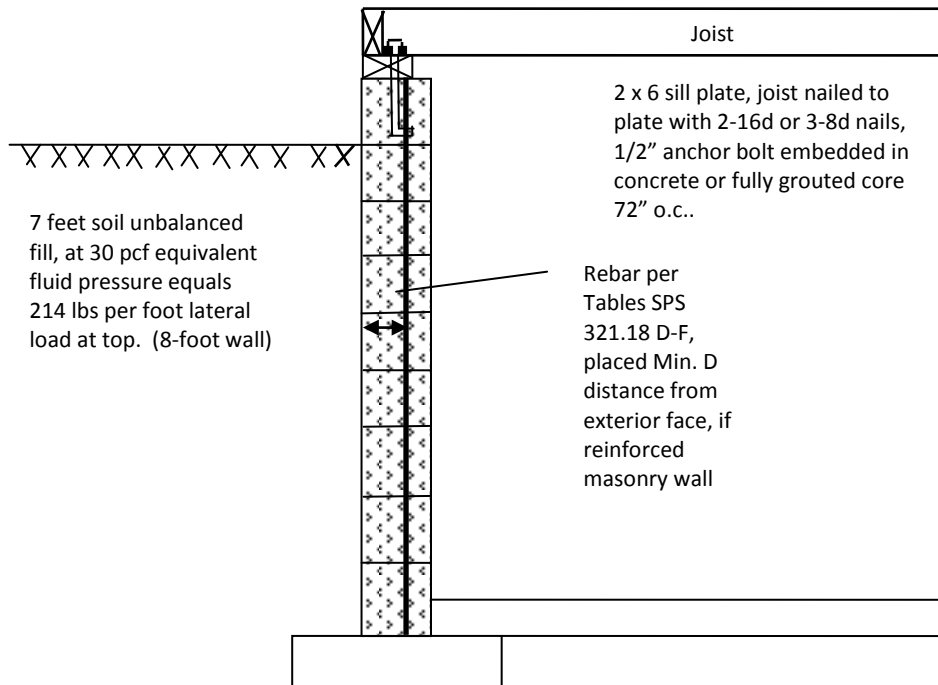

321.18(2) Concrete Foundation Walls

ACI 332-2014 provides minimum requirements for design and construction of structural plain concrete members (those with little or no reinforcement) such as footings and foundation walls in light residential applications. Unless foundation walls are alternatively designed and constructed in accordance with accepted engineering practice, section 8.2.5 and 8.2.9 of this standard require:

- Lintel beams at least 8" deep and not exceeding 40" in span
- Not less than two No. 4 bars shall extend at least 24" into the wall at each end
- At each corner, a diagonal, min 24" long No. 4 bar shall be secured as close as practical to the corner

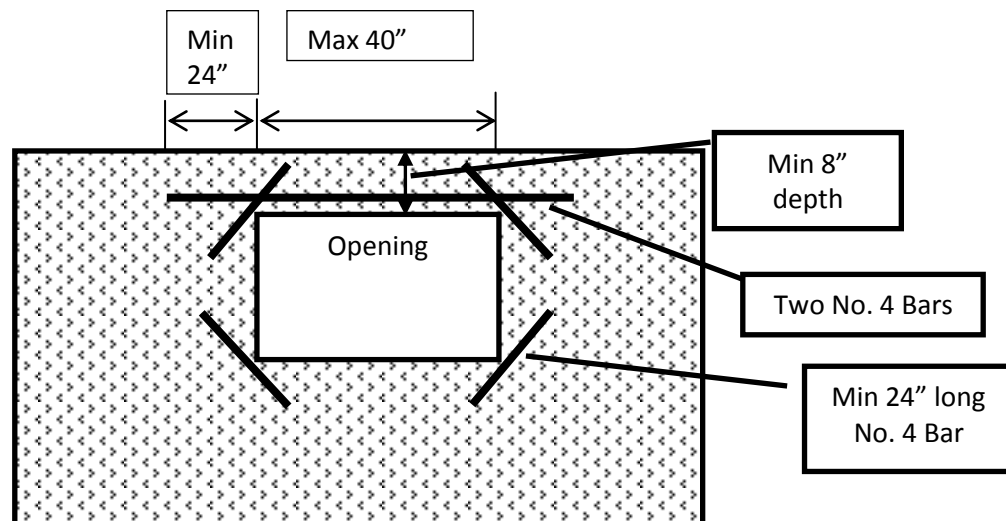

In addition to the prescriptive requirements of this section, concrete foundation walls may be designed per the adopted standards ACI 318 and 332.

Question: Is a 6-inch thick concrete foundation wall acceptable for supporting a 2 x 6 frame wall? The thickness of the frame wall with sheathing, siding, and drywall will exceed the 6-inch foundation wall thickness.

Answer: "In no case shall the thickness of the foundation wall be less than the thickness of the wall it supports." This requirement refers to the width of the structural members of the supported wall. In the wall in question, only the 2 x 6 framing (5.5 inches) are considered structural supporting members, therefore the proposed wall is acceptable.

Question: What does the term nominal wall thickness mean in Table 321.18-B?

Answer: This term was used for when a piece of lumber was used to set the thickness of the wall. That lumber may not have been the full 8 inches in width but had an actual thickness of 7.5 inches at one time. Currently, for softwood lumber of a nominal thickness of 8 inches, the actual thickness can be 7.25 inches. Although it is recommended that the full thickness specified in the table be used, the department will permit a wall to have an actual thickness less than that specified in the table but it may not be reduced by more than **1/2 inch.**

Question: Are there situations where the department will allow unreinforced concrete supporting walls thinner than specified in Table 321.18-B?

Answer: Yes, the code allows 6-inch unreinforced concrete walls to be used provided the fill is within 12 inches of being evenly balanced on both sides of the wall. The top of any concrete slab and the finish grade is used to determine this measurement, such as in an attached garage situation or slab-on-grade dwelling.

Question: What strength of concrete is a "five-bag mix"?

Answer: The strength of concrete is dependent upon a number of factors including the cement-water ratio involved in the mix. A five-bag mix means that 470 lbs. of cement is used per cubic yard of concrete. Without knowing how much water is also used per cubic yard of concrete, the actual design strength of the concrete cannot be determined. Concrete suppliers should have their design mixes tested prior to field use per the American Concrete Institute (ACI) specifications. (See following section.)

Concrete Foundation Walls (Concrete Quality)

Compressive Strength of Concrete

The average strength of concrete produced must always exceed the specified value of concrete strength (f'_c) that was used in the structural design phase. This is based on

probabilistic concepts, and is intended to ensure that adequate strength will be developed in the structure.

Acceptable Practice for Concrete Design

The specified strength of concrete for foundations and footings in one- and two-family dwellings shall be at least 2,500 psi per s. ACI 332-14. The height of 3,000 psi concrete foundation walls shall be governed by Table 321.18-B or alternately, for greater or lesser concrete strengths, through engineered design. It is noted that Table 321.18-B assumes the wall has lateral support at both top and bottom.

Proportioning on the Basis of Field Experience

For establishing concrete proportions, emphasis is placed on the use of laboratory trial batches or field experience as the basis for selecting the required water/cement ratio. If an applicable standard deviation for strength tests of the concrete is known, this establishes the target strength level from which the concrete must be proportioned. Otherwise, the proportions must be selected to produce an excess of target strength sufficient to allow for a high degree of variability in the strength tests.

Where the concrete production facility has a record based on at least 30 consecutive strength tests representing similar materials and conditions to those expected, the strength used as the basis for selecting proportions shall exceed the required specified strength of concrete (f_c') by at least:

TABLE A. REQUIRED OVERDESIGN

Standard Deviation (psi)	Required Average (psi)
Under 300	$f_c' + 400$
300 - 400	$f_c' + 550$
400 - 500	$f_c' + 700$
500 - 600	$f_c' + 900$
Over 600	$f_c' + 1200$
Unknown	$f_c' + 1200$

The indicated average strength levels are intended to reduce the probability of concrete strength being questioned on any of the following usual bases: (1) too many tests below specified f_c' ; (2) strength averaging below specified f_c' for an appreciable period (three consecutive tests); or (3) an individual test being disturbingly low (more than 500 psi below specified f_c').

Proportioning on Basis of Acceptable Practice

If test data is not available, the following water/cement weight ratio may be used to determine acceptable concrete strength.

3000 PSI concrete, use 0.58 water/cement ratio

The following tables give guidelines for proportioning a mix of 1 cubic yard to develop acceptable strength levels. Recommended slump for footings, foundation and slabs is between 1 and 3 inches.

TABLE C APPROXIMATE MIX FOR SLUMP OF 1-2 INCHES

<u>Size</u> <u>Aggregate</u>	<u>Water</u> <u>Lbs.</u>	<u>Gallons</u>	<u>3000 PSI</u>		<u>Percent*</u> <u>Volume</u> <u>of Coarse</u> <u>Aggregate</u>
			<u>LB. of</u> <u>Cement</u>	<u>94#</u> <u>Bags</u>	
1/2"	335	40	578	6.2	50-60
1"	300	36	517	5.5	64-72
1 1/2"	275	33	474	5.0	68-76
2"	260	31	448	4.8	71-79

TABLE D APPROXIMATE MIX FOR SLUMP OF 3-4 INCHES

<u>Size</u> <u>Aggregate</u>	<u>Water</u> <u>Lbs.</u>	<u>Gallons</u>	<u>3000 PSI</u>		<u>Percent*</u> <u>Volume</u> <u>of Coarse</u> <u>Aggregate</u>
			<u>LB. of</u> <u>Cement</u>	<u>94#</u> <u>Bags</u>	
1/2"	365	44	629	6.7	50-60
1"	325	39	560	6.0	64-72
1 1/2"	300	36	517	5.5	68-76
2"	285	34	508	5.4	71-79

*Percent of coarse aggregate will vary with different fineness moduli of sand.

321.18(2) Dampproofing

Question: Could you clarify the UDC requirements for waterproofing of poured concrete foundation walls?

Answer: This section only specifically addresses dampproofing of masonry foundation walls. Section SPS 320.24 adopts American Concrete Institute's standards ACI 318-14 and ACI332-14 for reinforced and plain concrete. This standard does not mention waterproofing requirements. In summary, there are no requirements for waterproofing of poured concrete walls in new one- and two-family dwelling construction.

Question: Does a masonry foundation wall have to be dampproofed before the insulation is applied?

Answer: Yes, this section requires dampproofing of masonry foundation walls of basements. The exterior applied insulation may then be installed. Alternate systems do exist that use a layer of insulation. These need a Wisconsin Building Material Approval or show equivalency with the code's dampproofing requirements.

321.18(3) Masonry Foundation Walls

In addition to Tables 321.18-B, C, D, or E, designers may use the adopted standards ACI 530 and 530.1 to design concrete masonry walls.

Subchapter VI—Floors

321.203 Garage Floors

Question: Can the garage floor be at the same elevation as the finished floor of the dwelling or is a step or landing required in the garage at a door between the two?

Answer: The code doesn't require an elevation change between the garage floor and the dwelling floor, only that the garage floor slope to the main exterior opening or floor drain. Some local ordinances required a step, but no national building codes have required a step there. In fact, builders who are concerned with handicap accessibility are promoting the same height floor level for garages.

Question: What is the minimum pitch of the garage floor?

Answer: The code is silent on this and doesn't prescribe the degree of pitch, only that it must have a slope to provide drainage. A suggested rule of thumb for concrete flat work is 1/8 inch drop per foot of run.

321.205 Wood Floors in Contact with the Ground

Such floors would also have to comply with SPS 321.10(1) to (5) for decay prevention.

321.22(1) Floor Joist Design

Question: Does the deflection of floor joists have to be limited to the $L/360$ as shown in the upper left corner of Table J-1 found in the code appendix.

Answer: There is no requirement in ch. SPS 321 stating what the maximum deflection of floor joists members must be, so it is left to the designer's judgement.

321.22(1) Floor Joists and Sill Plates

Question: A wood floor joist system is resting on a sill plate which in turn rests on a hollow concrete masonry foundation. Does the top course of masonry need to have all cores and joints filled with mortar?

Answer: Per s. SPS 321.22(1)(d), the cores of the blocks need not be filled as long as a sill plate is as wide as the block. If a sill plate is smaller, than the width of the block or if a sill plate is not used, then all the cores of the top course must be filled.

321.22(3) Beam Lateral Restraint

Wood beams deeper than 11.25" shall be provided with lateral restraint at supporting columns by means of a saddle or other approved connection. A saddle supports the beam on the bottom, but also allows through-connection of fasteners into the side of the beam.

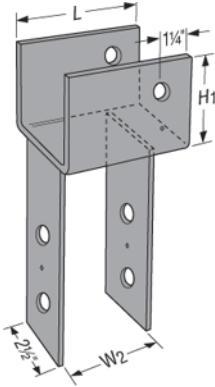

321.22(3) Steel Beams

Question: Please explain the terminology for steel beams in Table 321.22-A1.

Answer: A-36 steel refers to the strength of the steel. It has an allowable tensile yield strength of 36,000 pounds per square inch. Most beams are now A-50 steel.

The designations W and M refer to the standard cross-sectional shapes of steel beams. The term I beam is no longer used, but does describe the general shape of these beams. The major differentiating characteristics of a beam are its top and bottom flanges which are horizontal and the vertical web which separates the flanges. The specific descriptions are:

"W" - The top and bottom flanges are parallel to each other. Previously called a wide flange beam in some cases.

"M" - Cannot be classified as a W or S shape. Sometimes referred to as a junior I beam previously.

It is always best to get the actual shape designation from the suppliers. The two numbers after the shape designation (W, M) provide (1) the overall depth of the beam section and (2) the weight of the beam itself in pounds per lineal foot.

So a beam designated as a W 8 x 15 has a W shape with relatively wide flanges, a depth of 8 inches and weighs 15 pounds per lineal foot.

Question: Table 321.22-A1 gives sizes for wood or steel beams when conventional framing is used. Table 321.22-A2 gives sizes of wood beams when truss roofs are used. Are there sources that can be used to more economically size steel girders and beams when using truss roofs?

Answer: Any tables or calculators that use the method of design adopted by the UDC in AISC 360 would be acceptable.

321.22(4) Floor Joist Tails

Question: Why can't the tail ends of joists overlap by more than the depth of a floor joist over a supporting beam?

Answer: The reason for the requirement is to prevent potential subfloor uplift from the tail end reaction to the deflection of the joist span. This could be more of a problem at the center beam of a house in which clear span roof trusses are used and there is no bearing wall bearing on the floor joist tail ends.

Question: Can wood shims be used under a steel beam or under a steel column for minor dimensional adjustments? What about pressure treated lumber?

Answer: Maybe, but not likely, since the shim material used would need a compressive strength equal to or greater than the loads imposed by the typically highly loaded steel members. If structural calculations are lacking on this point, then steel shims would be required.

321.22(5) Notching & Boring of Joists

Holes & Notches in Sawn Joists and Rafters (D = Actual Member Depth)			
Member Size	Maximum Hole Diameter or Notch Length = D/3	Maximum Edge-Hole Diameter or Notch Depth (except at ends) = D/6	Maximum End Notch = D/4
2x6	1-3/4"	7/8"	1-3/8"
2x8	2-3/8"	1-1/4"	1-7/8"
2x10	3"	1-1/2"	2-3/8"
2x12	3-3/4"	1-7/8"	2-7/8"

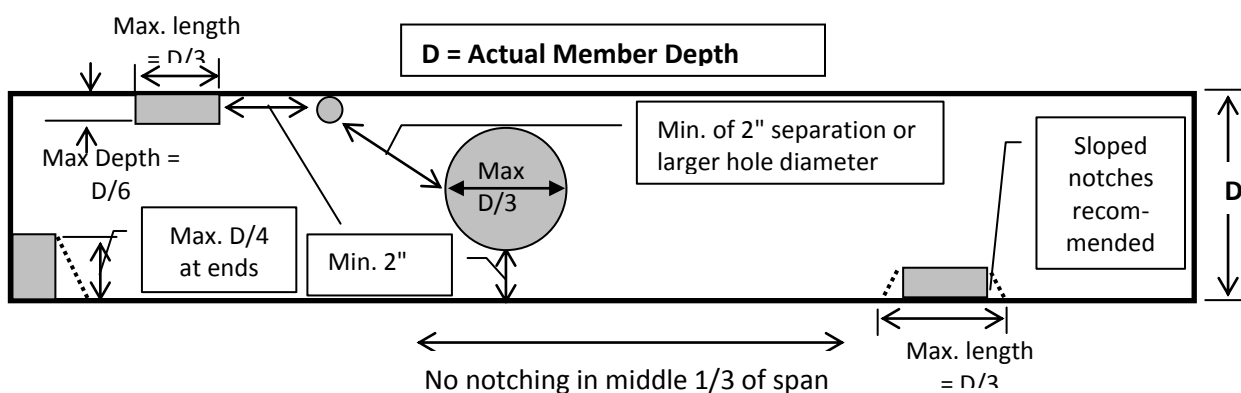

321.22(6) Joist Cantilevers

This section and these drawings are applicable to solid-sawn 2X wood joists, not engineered wood products.

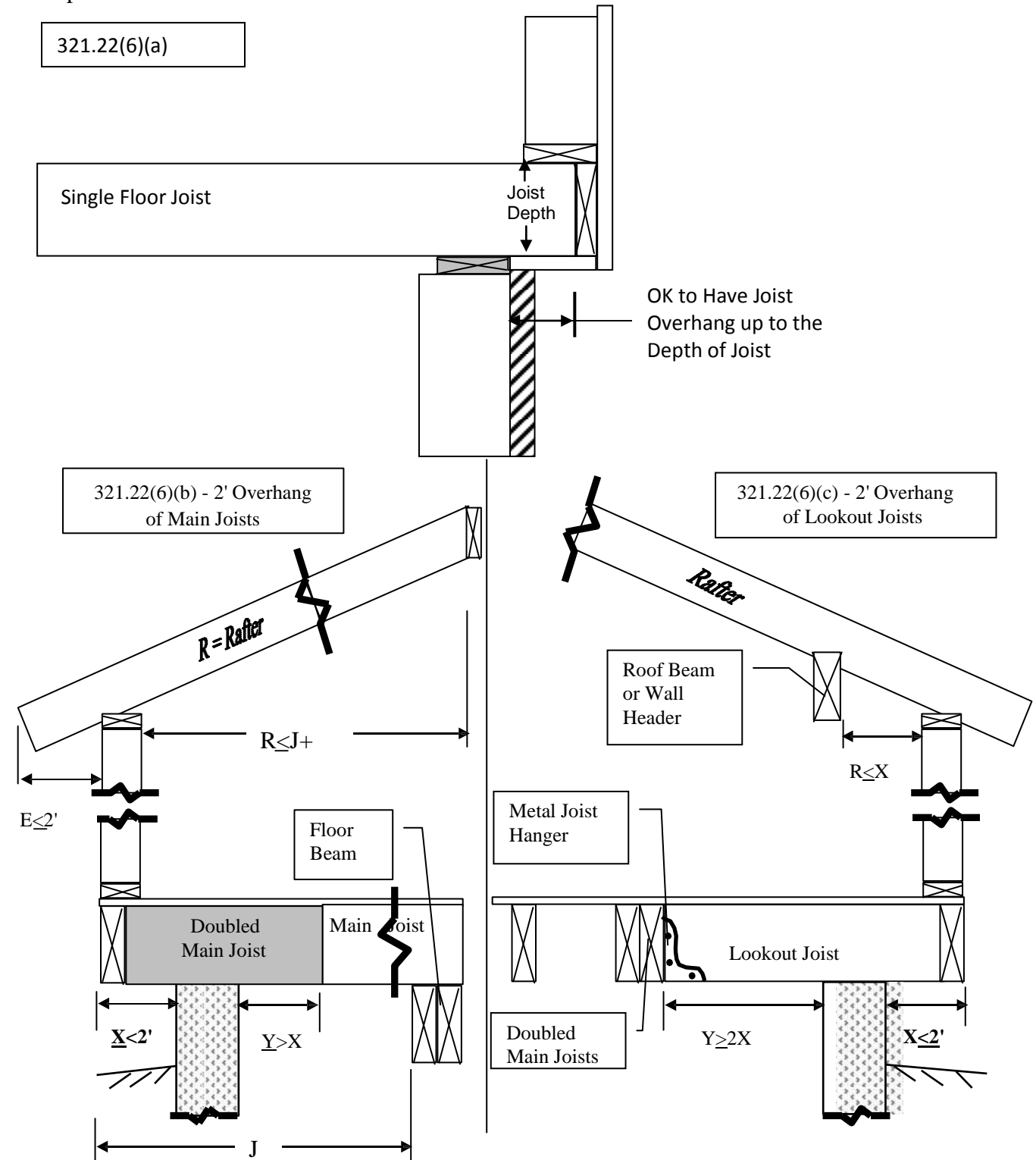

321.22(7) Joists Bearing Over Window Openings

In the absence of a wall header, the requirements of SPS 321.22(7) apply to floor joists that bear on a rim joist above a window or other wall opening. This is typically the case for basement windows. Therefore, either framing anchors or a ledger strip, such as a sill plate, is required for proper bearing for any joists over 8 feet long.

321.22(9) Bridging

These bridging requirements assume that floor sheathing per (8) of this section is also present to provide continuous compression edge bracing of the joists as required by NDS 4.4.1.

321.22(10) Sill Plate Details

Question: A wood floor joist system is resting on a sill plate which in turn rests on a concrete foundation wall and is anchored to the foundation wall with anchor bolts required by s. SPS 321.18 (1) (c). What is the minimum width and location of the sill plate relative to the anchor bolt to meet the intent of providing lateral restraint at the top of the foundation wall?

Answer: Per s. 321.22(10)(a) the centerline of a ½" anchor bolt shall be located no less than 2" from the edge of the plate. Per ACI 332 s. 5.6 the edge of the embedded portion of the anchor bolt shall have no less than 1.5" of concrete cover.

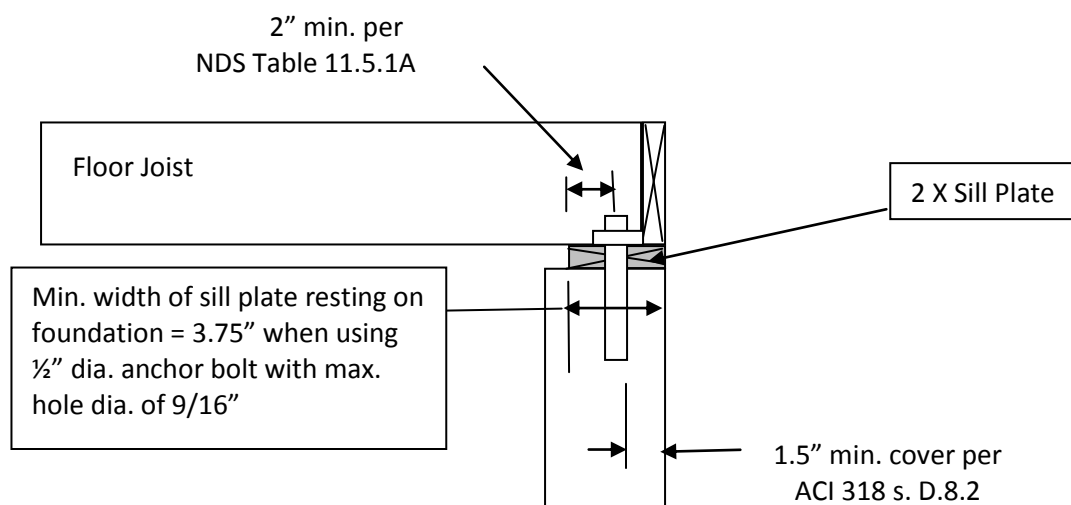

Question: I wish to place more insulation on the exterior of my foundation than my frame wall above. I do not want the foundation insulation to protrude beyond the siding. How may I project my frame construction beyond the foundation wall to accomplish this?

Answer: Per s. 321.22(6), you may cantilever a joist that is **perpendicular to its supports** up to its depth beyond its support, or further with additional framing – see the commentary for that section for drawings. Otherwise per

s.322.22(10) and engineering mechanics, you may overhang a single sill plate $\frac{1}{2}$ of its nominal thickness, which for a 2X sawn lumber sill plate would allow a 1" overhang. This is based on loads flowing in a 45 degree path to the stiffest members. Likewise, this concept may be applied to other blocking members that are intended to bear floor loads, wall loads or both - see the figures below. Note that these examples are for uniform loading conditions. For 2x floor framing, concentrated loads produced by more than a doubled stud above may require additional blocking between the floor sheathing and sill plate. Also note that the examples are for solid sawn joists, except as noted for Options 1 & 2, which may be used with any supported floor system, however **any** non-uniform loads from above shall be per the manufacturer of any engineered floor system. Consult with manufacturers of engineered wood products to obtain other acceptable installations of their products. Also following are details for floor trusses supplied by the SBCA.

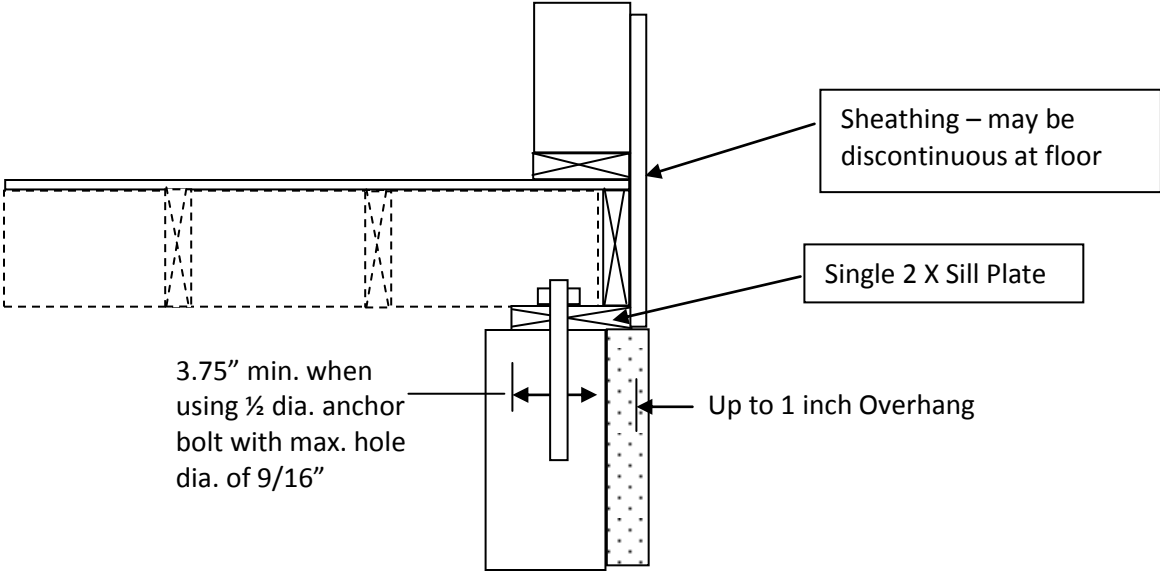

Option 1 - Single Sill Plate Overhang With Floor Framing Perpendicular or Parallel to Foundation

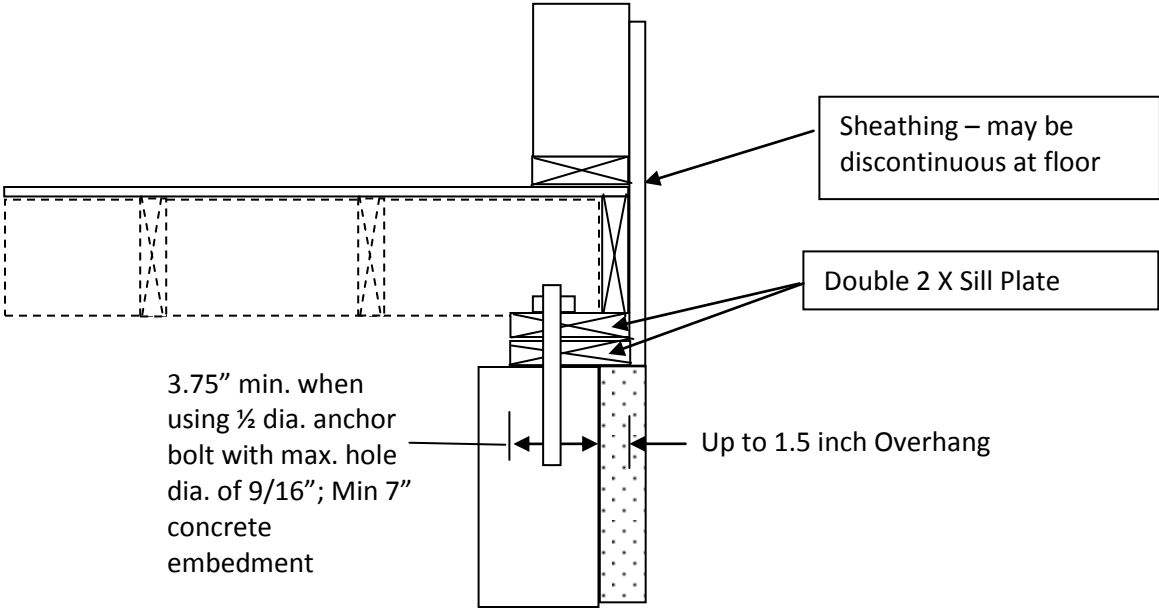

Option 2 – Double Sill Plate With Floor Framing Perpendicular or Parallel to Foundation

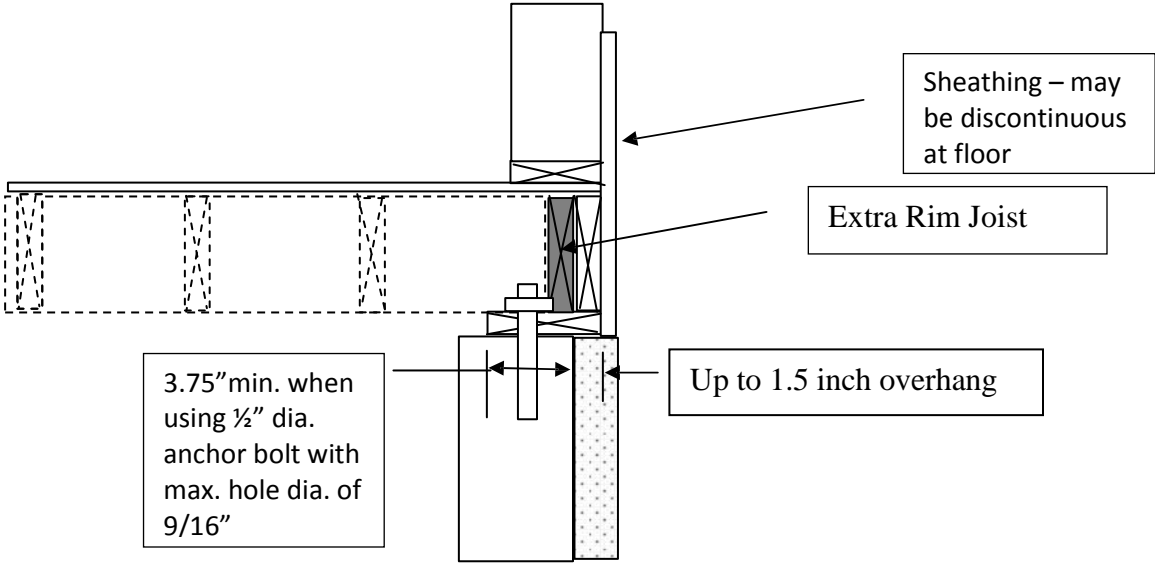

Option 3 – Double Rim Joist With 2X Framing Perpendicular or Parallel to Foundation Wall

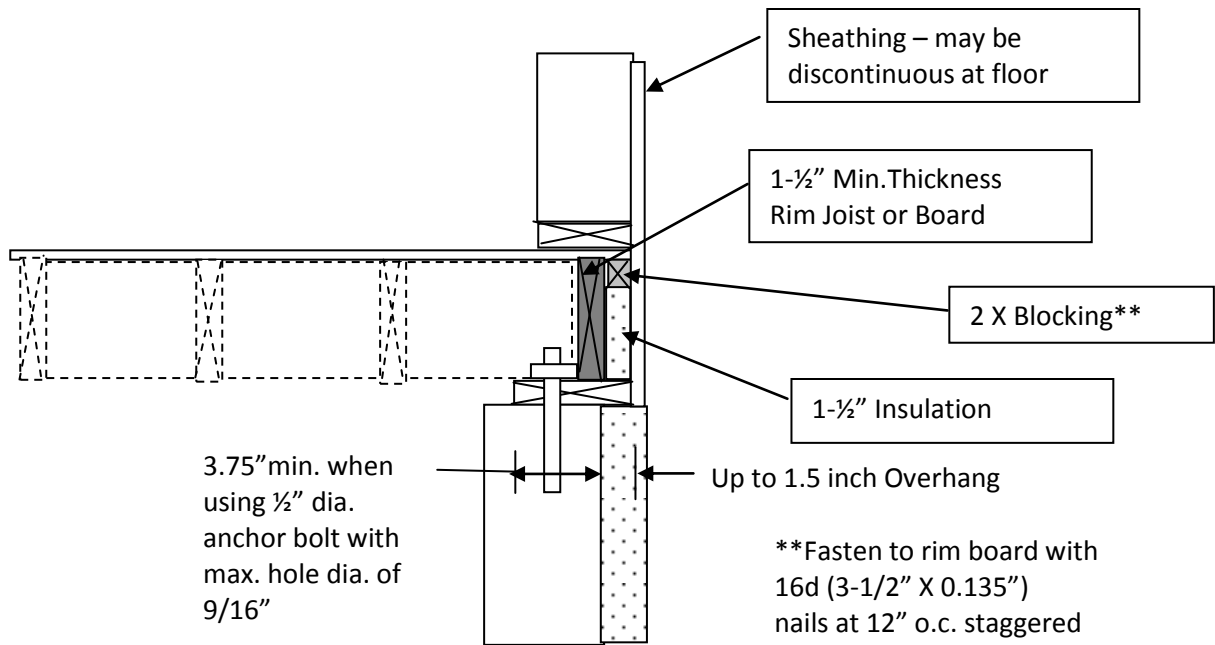

Option 4 – Double Rim Joist With 2X Framing Perpendicular or Parallel to Foundation Wall

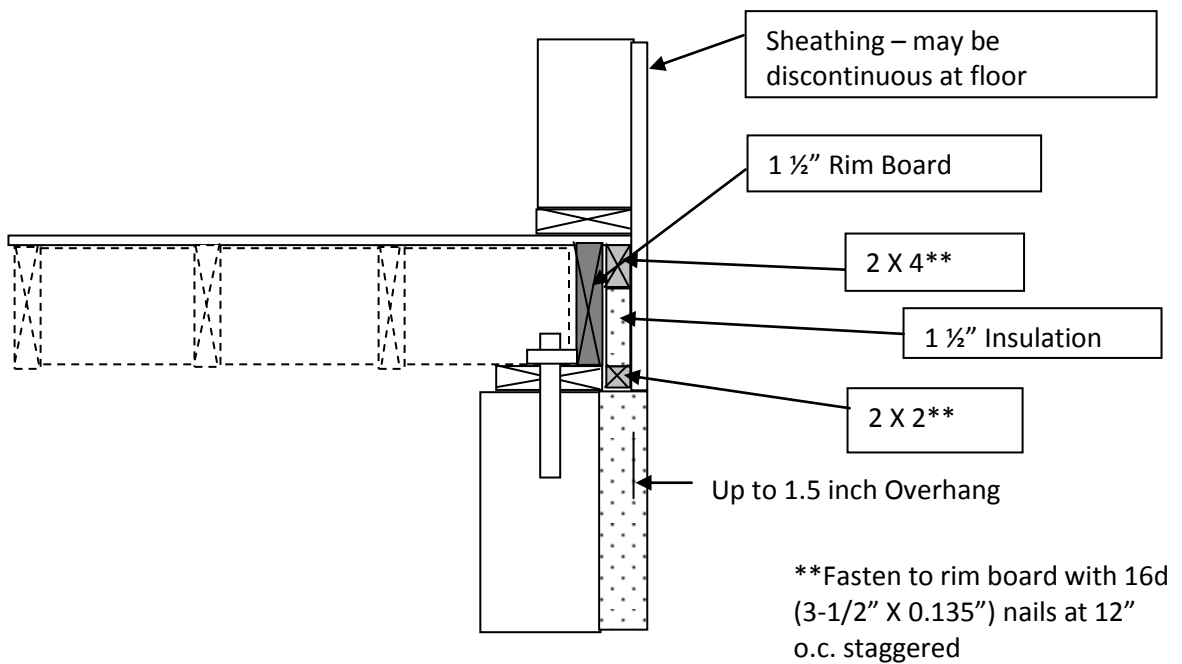

Option 5 – Double Rim Joist With 2X Framing Perpendicular or Parallel to Foundation Wall

321.22(4) Details for floor trusses manufactured by members of the Structural Building Components Association (courtesy of SBCA)

These detail address the issue of cantilevered sill plates supporting metal plate connected wood trusses installed parallel and perpendicular to the foundation walls where there is a potential for discontinuous planes between the exterior wall above the sill plate and the foundation insulation planes. The example below is based on the following assumptions:

- Exterior wall sheathing is any thickness to align the exterior face of the sheathing with the exterior face of the sheathing below.
- Basement continuous insulation is installed on the exterior of the foundation and does not exceed 2".
- Floor system is bottom chord bearing metal plate connected wood trusses.
- The sill plate does not overhang the foundation by more than 1-9/16".

It is important that all structural, energy, and durability requirements be taken into account.

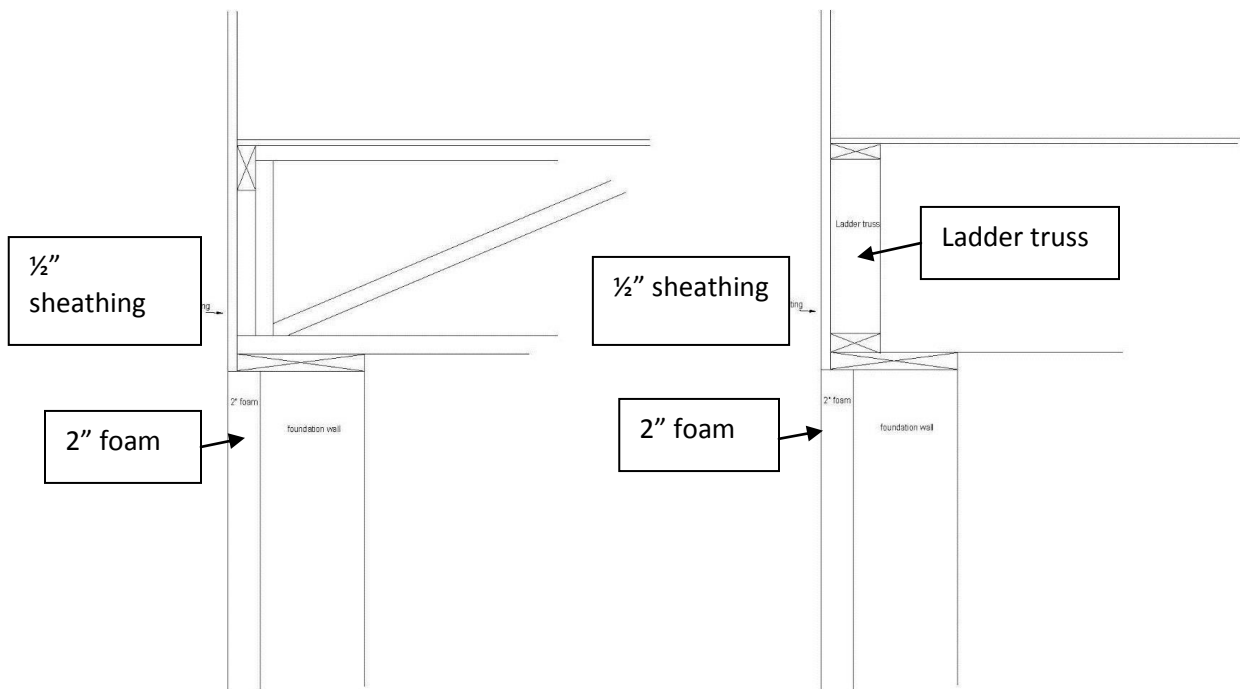

321.225 Decks

Decks are the location of many occupant deaths and injuries, many due to structural deficiencies such as inadequate connections of ledger boards, guards and posts. This code provides various prescriptive, or cookbook, methods of complying with the code requirements, that are typically conservative because of the unknown, specific project conditions. It also allows for individually engineered designs that take advantage of all specific project conditions, as well as alternate generic designs that are based on the UDC loads, materials and methods of design. These generic methods can include tables, calculators, guides and other tools. Their limitations must also be followed. In some cases, these limitations will be more restrictive than that UDC, but are necessary for the overall designs. With proper documentation, conservative substitutions may be allowed. In other cases, these alternate generic designs may differ from the UDC for issues that are not related to the need for the overall design to work. In such cases, per SPS 320.01, the UDC provisions would be the minimum and maximum enforced provisions.

Appendix B provides an acceptable method of designing a deck, at the owner's option. It is mainly based on the 2012 American Wood Council standard Design for Code Acceptance 6 (DCA-6) – Prescriptive Residential Wood Deck Construction Guide. Note that DCA-6 is based on the 2012 International Residential Code. Appendix C of the UDC provides supplementary acceptable methods of designing a deck. See Appendices B and C of this Commentary for additional discussion of those documents. Designs based on DCA-6 would also be acceptable.

When using UDC ch. 321 to design a deck, the designer needs to also address the seasonal wetting and drying cycles and UDC-adopted NDS requirements for such decks, including:

- Fastener creep or pullout, including that caused by excessive member deflection
- Wood member splitting
- Tension perpendicular to grain that may limit side bolting of wood bending members
- NDS wet service factors
- Lateral support of deck joists by other means if decking is not rigidly connected to the joists

Appendix B and other available deck design tools often require lateral bracing by means of knee braces, diagonal decking, tension-ties at the ledger board or hold-down tension devices into the dwelling floor system to address various lateral loads from seismic, wind and dynamic occupant loads. These will typically more than satisfy the UDC required lateral wind loads of 20psf of s.321.02. A designer may show compliance with other lesser methods as well. However, note that additional lateral bracing may be prudent to address the significant swaying loads that human occupancy of a deck may create. An economical and simple method of increasing lateral load resistance of a deck system is to use screws rather than nails to fasten joist hangers to the ledger board.

321.24 Water-Resistive Covering Installed Prior to Insulating

Note that this requirement includes uninsulated gable and dormer walls that are above insulated assemblies.

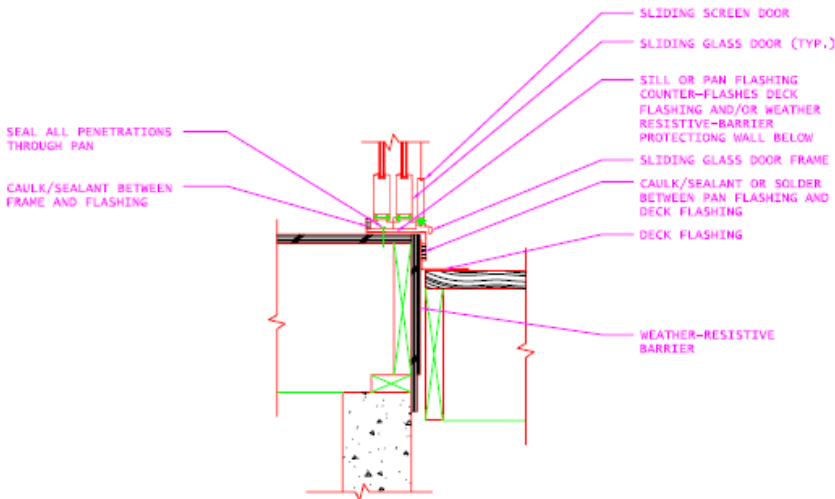
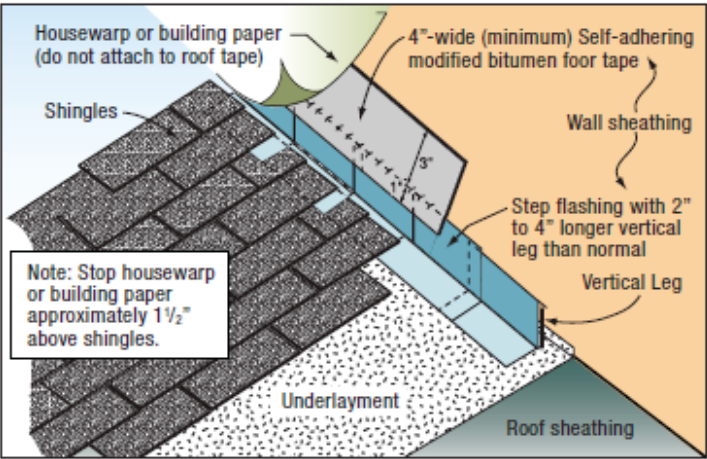
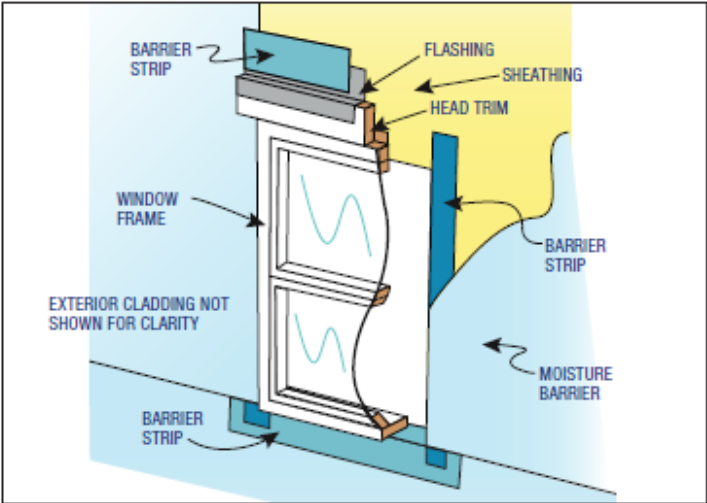

SILL FLASHING AT SLIDING GLASS DOOR

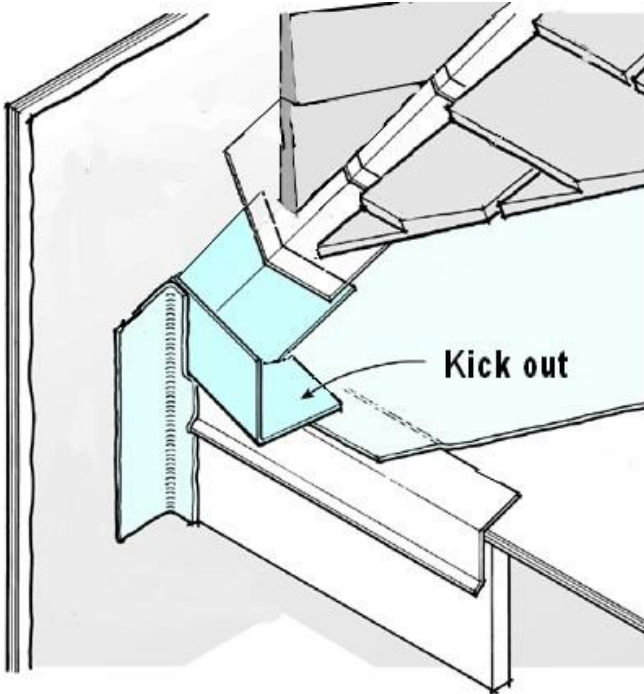
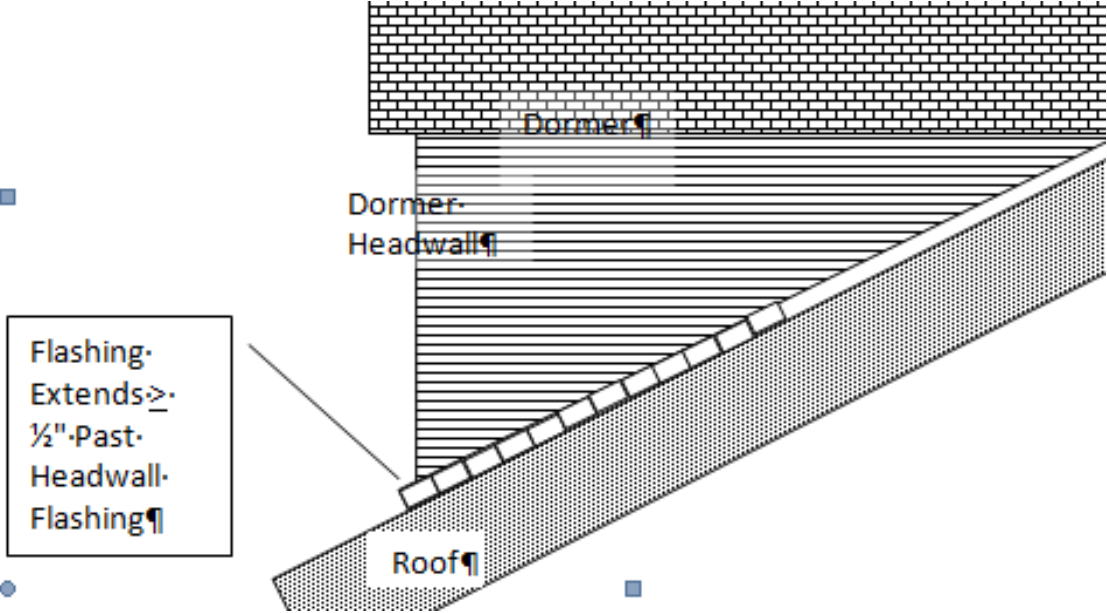

321.24(3) Flashing Details

321.25(1) Stud Configuration at Vaulted or Cathedral Ceilings

Per footnote a. to Table 321.25-A, allowable stud heights are measured between points of lateral support, typically provided by foundation anchors, floor/ceiling assemblies and roof/ceiling

assemblies. If there is no rigid ceiling finish, additional diagonal bracing from the gable end into the ceiling or roof framing or both may be required. If roof trusses are being used, this bracing needs to be coordinated with the design and permanent bracing of the trusses. In the case of vaulted or cathedral ceilings, the studs shall be continuous to the ceiling.

321.25(2m) Allowable Bottom Plate Overhangs

The code allows the single bottom plate of a wall to overhang the foundation by one inch. This is based on loads flowing in a 45 degree path to the stiffest members. In order to accommodate greater thicknesses of exterior foundation insulation, this same concept may be applied to multiple plate thicknesses as shown below. These overhangs are also acceptable with point loads produced by multiple studs or a column.

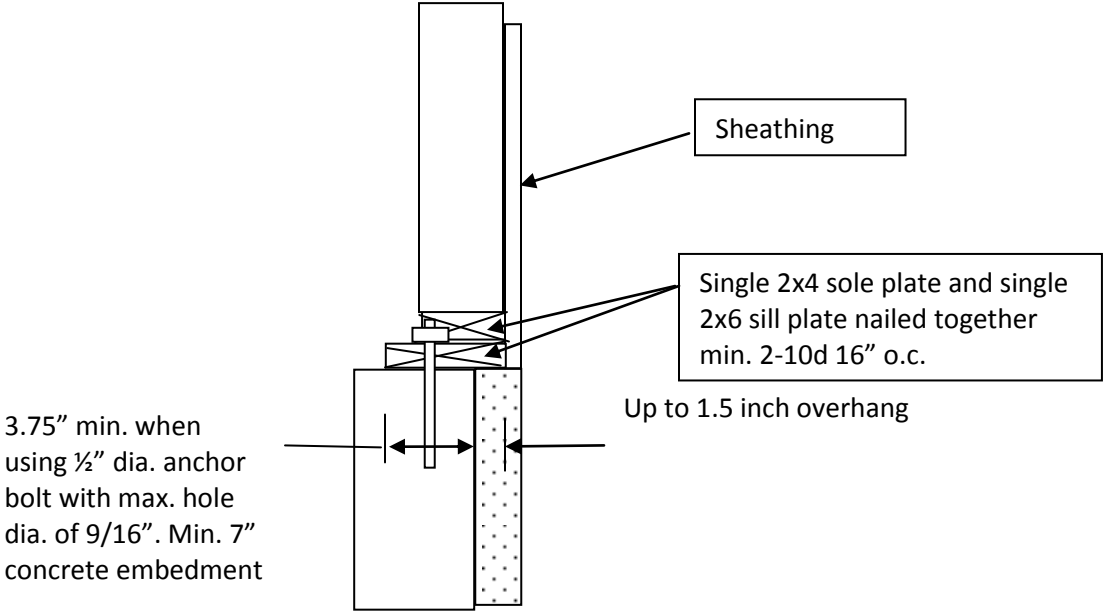
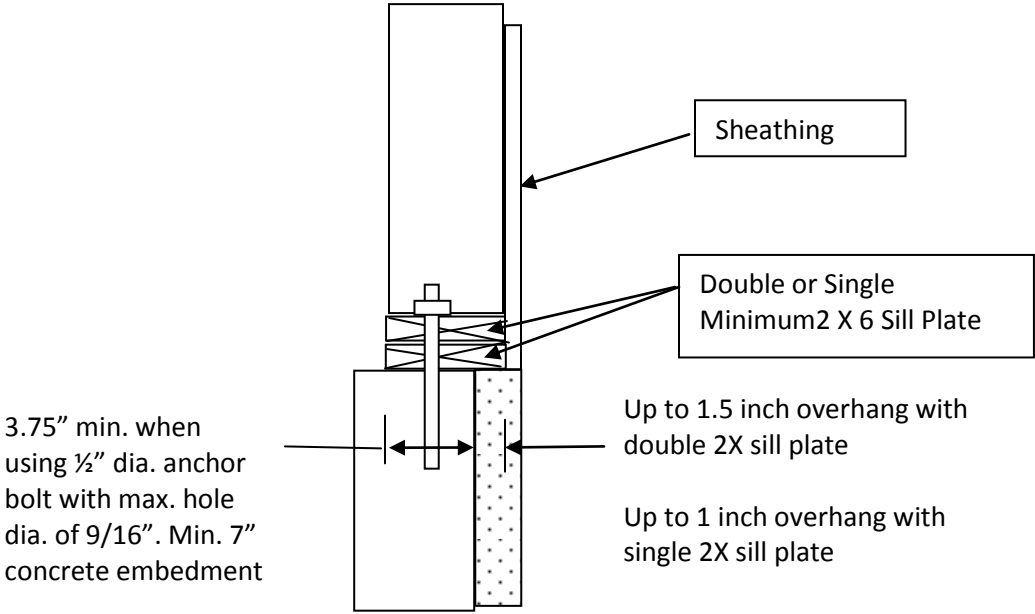

321.25(3) Wall Opening Framing

Wall Header spans greater than shown by the UDC header tables are acceptable using other tables and calculators based on the NDS standard adopted by the UDC.

SPS 321.25(3)(b) prescribes header support minimum standards. The following diagrams are intended to clarify the text. Remember that the “span” is the clear span plus 1/2 the required bearing area of the header at each end.

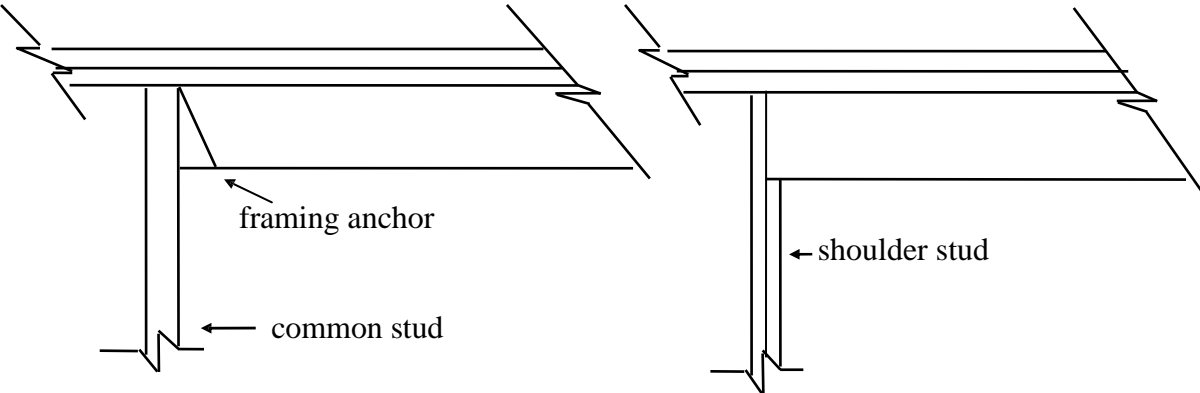

Either option for up to a 3-foot span.

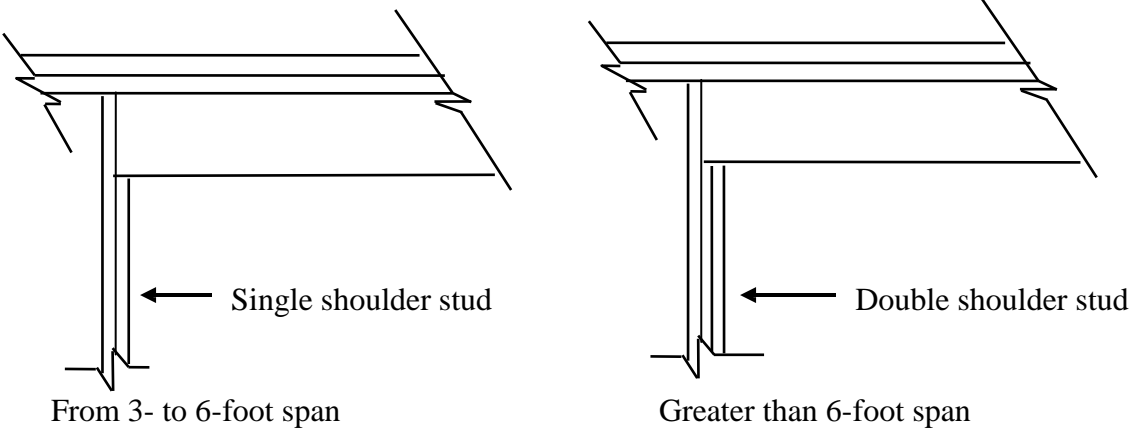

From 3- to 6-foot span

Greater than 6-foot span

321.25(6) Telescoping Columns

Question: Are telescoping or expandable jacks or columns allowed in the construction of one- and two-family dwellings?

Answer: The use of the telescoping jack post (adjustable height columns) to support beams is not prohibited by the UDC provided they are capable of supporting the imposed loading per SPS 321.25(6)(c)1. The installation shall comply with the manufacturer's installation instructions for spacing, load capacity, maximum height adjustment, beam or footing anchorage and proper method to secure the adjustment device while in service. The adjustable jack should

be stamped or bear a sticker which indicates its allowable load. They must be secured at both the top and bottom of the column the same as any other column. Caution should be used on the limitations of screw adjustment permitted for a particular load and even which end is up must follow listing.

321.25(7) Foundation Cripple Walls

This section addresses the potential hinge and racking action allowed by a wood-frame wall placed on a partial-height masonry or concrete foundation wall, typically of a ground floor or walk-out basement. There is limited lateral support for the top of the foundation wall to resist any soil loads as compared to that provided by a floor system. Foundations for cripple walls shall have anchor bolts per SPS 321.18(1)(c) and SPS 321.22(2m) as well.

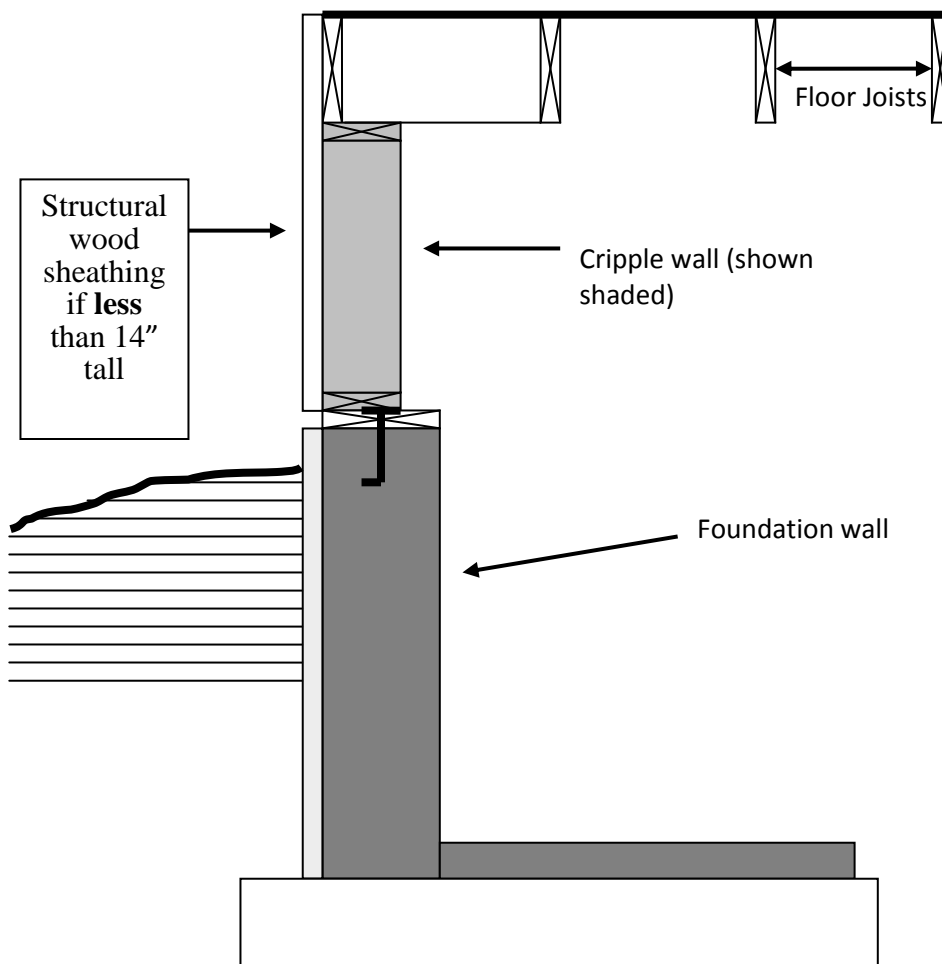

321.25(7) & (8) Wall Bracing

Since the first edition of the Uniform Dwelling Code (UDC) that became effective June 1, 1980, the UDC has required construction that resists lateral wind loads of 20 pounds per square foot of external wall area. These changes in the rules for wall bracing in recent years

incorporate more design and construction specifications in an effort to assure the long-standing performance requirement is met.

The current provisions are generally based on the 2012 IRC Simplified Wall Bracing Provisions. The prescriptive code tables provide the number of braced wall panels required on a rectangle side (intermittent sheathing method) OR the total length of braced wall panels required on a rectangle side (continuously sheathed method) in wood frame walls parallel to the wind direction being considered.

Major Assumptions/Defaults, Unless Adjustments Are Made Per Table Footnotes:

- Interior side of exterior walls are sheathed with ½" gypsum board
- Maximum 10' wall heights
- Wind Exposure category B
- For the intermittent bracing method roof eave (top of wall) to ridge height is 10'

Starting with the topmost floor level ...

STEP 1: Define the rectangle sides by circumscribing the outermost extents of the building at each floor level with a rectangle. The maximum length of any side of the rectangle is 75' for intermittent bracing and 80' for continuously sheathed bracing. For either method, the maximum length to width ratio of the rectangle is 3:1. If the length of the rectangle side exceeds the prescriptive limit of the respective table or the length to width ratio exceeds 3:1 the building must be circumscribed or divided with more than one rectangle or designed by engineering analysis. See - Figure 321.25-B in the UDC.

STEP 2: Select the wall bracing method (intermittent or continuous), materials, and panel width (intermittent method) from Table 321.25-G. If using intermittent braced wall panels, in general most of the bracing methods are considered equivalent and the method simply tells you the NUMBER of panels required on a rectangle side. For continuously sheathed bracing, the method yields the total full-height braced LENGTH wall required on a rectangle side.

STEP 3: DETERMINE NUMBER OF PANELS OR REQUIRED TOTAL LENGTH OF BRACING REQUIRED USING ONE OF THE FOLLOWING METHODS

- A) Intermittent braced wall panels. Determine the NUMBER of braced panels required on each rectangle side using Table 321.25-I based on the length of the **perpendicular** side. NOTE a minimum of 2 braced wall panels is required on each rectangle side.

OR

- B) Continuously Sheathed braced walls. Determine the TOTAL LENGTH of braced full-height wall panels on each rectangle side using Table 321.25-J based on the length of the **perpendicular** side.

STEP 4: If required, apply any adjustment factors (adjustments may decrease or increase the required bracing amount) per the footnotes to the respective Table for the method used

(intermittent or continuous). For example wall heights taller than 10' and wind exposure category C or D would both increase the bracing amount. Absence of interior ½" gypsum board sheathing increases the required bracing amount.

STEP 5: Repeat steps 2 through 4 considering wind in the perpendicular direction.

STEP 6: Determine the minimum required width of braced wall panels. For intermittent bracing method the minimum length of braced wall panel is given in Table 321.25-G. For continuously sheathed bracing method, the minimum width is determined using Table 321.25-H dependent on the maximum opening height adjacent to the panel and the wall height.

PF (Portal Frame) Method: Portal Frame narrow panel bracing may be used with either the intermittent or continuously sheathed bracing methods. For Intermittent bracing, per Table 321.25-I footnote 'h', each PF panel (16-24" wide per Figure 321.25-A) counts as ½ of a braced wall panel when determining compliance with Table 321.25-I. For Continuously Sheathed bracing, the actual length of each PF panel (16-24" wide per Figure 321.15-A) in feet, counts toward the required total length of bracing required.

STEP 7: Check that the location of braced wall panels meets Figure 321.25-C. A braced wall panel must start within 12-½' from the end of the rectangle side and braced panels must be spaced a maximum of 21' edge to edge along the rectangle side. For intermittent or continuous methods, each PF panel meeting the minimum required width of Fig. 321.25-A counts as a braced wall panel when evaluating compliance with Fig. 321.25-C.

The following Wall Bracing Compliance Worksheet and indicated plan details may be used to show compliance.

Wall Bracing Compliance Worksheet

Complete this worksheet or provide equivalent information on the plans submitted with the permit application.

Sketch and dimension the building plan and the wall bracing rectangle(s) per 321.25(8)(c)1. and Figure 321.25-B. Provide and label additional sketches if the building plan/rectangles change at different floor levels.

Indicate applicable Wall Bracing Method for each level (see Table 321.25-G), each labeled rectangle if more than one [see 321.25(8)(c)], and amount of bracing (# of braced panels or length of braced wall required) per the respective table (provide additional worksheets for additional rectangles as needed):

Rectangle: _____ Wall Ht. = _____ Eave to Ridge Ht. = _____ Max. Opening Ht. = _____ Wind Exp. = _____

Walls Supporting:	Intermittent method (LIB, DWB, WSP, SFB, GB, PCP) and # of panels per Table 321.25-I Min. panel width (Table 321.25-G) = _____		Continuous method (CS-WSP, CS-SFB) and total length required per Table 321.25-J Min. panel width (Table 321.25-H) = _____		PF Method (see Figure 321.25-A). Indicate number of PF panels 16-24" wide provided. Min. PF width (Fig. 321.25-A) = _____	
	Long side	Short side	Long side	Short side	Long side	Short side
Roof and ceiling only						
One floor, roof and ceiling						
Two floors, roof and ceiling						

Rectangle: _____ Wall Ht. = _____ Eave to Ridge Ht. = _____ Max. Opening Ht. = _____ Wind Exp. = _____

Walls Supporting:	Intermittent method (LIB, DWB, WSP, SFB, GB, PCP) and # of panels per Table 321.25-I Min. panel width (Table 321.25-G) = _____		Continuous method (CS-WSP, CS-SFB) and total length required per Table 321.25-H Min. panel width (Table 321.25-H) = _____		PF Method (see Figure 321.25-A). Indicate number of PF panels 16-24" wide provided. Min. PF width (Fig. 321.25-A) = _____	
	Long side	Short side	Long side	Short Side	Long side	Short side
Roof and ceiling only						
One floor, roof and ceiling						
Two floors, roof and ceiling						

PF Method: For Intermittent bracing, per Table 321.25-I footnote 'h', each PF panel (16-24" wide per Figure 321.25-A) counts as 1/2 of a braced wall panel when determining compliance with Table 321.25-I. For Continuously Sheathed bracing, the actual length of each PF panel (16-24" wide per Figure 321.25-A) in feet counts toward the required total length of bracing required. For intermittent or continuous methods, each PF panel meeting min. required width of Fig. 321.25-A counts as a braced wall panel when evaluating panel spacing per Fig. 321.25-C.

Indicate the location and construction details of required braced wall panels determined above on each rectangle side as required by Figure 321.25-C on the floor plans submitted with the permit application.

Question: Section 321.25(8)(a) and Figure 321.25-B. How do the wall bracing provisions apply to methods of construction other than 'stick built' such as post frame, log homes, structural insulated panels (SIP's), insulated concrete forms (ICF's), etc.? How do you apply the wall bracing provision to a home with a walk out basement where some of the walls are concrete and other walls or portions thereof are wood-framed?

Answer SPS 321.25 (8) WALL BRACING. (a) General. Dwellings using wood-framed walls shall be braced in accordance with this section. Where a building, or a portion thereof does not comply with one or more of the bracing requirements in this section, those portions shall be designed and constructed in accordance with accepted engineering practice. The code language above indicates the requirements only apply to wood-framed walls, i.e., stick built with studs max 24" o.c. Therefore other methods of construction must be designed per applicable adopted standards and accepted engineering practice.

Question Table 321.25-G. Can bracing materials and methods be mixed & matched on the same floor level or from one floor level to the next?

Answer Yes, bracing materials can be mixed on any given rectangle side, within a story or from one story to the next. In addition, bracing methods either intermittent or continuous can be mixed within a story or from one story to the next. However, on any given rectangle side you cannot mix intermittent and continuously sheathed methods.

Question Table 321.25-G footnote 'a', Table 321.25-I footnote 'e', and Table 321.25-J footnote 'd'. Are braced wall panels on a gable end wall required to be sheathed full height on the interior with ½" gypsum board where the wall extends above the ceiling and faces normally unfinished attic space on the interior of the dwelling?

Answer Yes, unless the required amount of bracing on the rectangle side is increased by the applicable 1.4 adjustment factor per Table 321.25-I footnote 'e' or Table 321.25-J footnote 'd'.

Question When using Tables 321.25-I and J, how is the top-of-wall-to-ridge height measured on gable ends?

Answer The intent is measure the "sail area" that a roof face exposes to the wind (regardless of how it is internally framed), so it measured from the eave elevation of the non-gable walls to the ridge.

Question Figure 321.25-A. Does the portal frame design require 7/16" OSB or plywood on all sheathable surfaces?

Answer It depends on the bracing method being used for that rectangle side. If using

the intermittent method - No. If using the Continuously Sheathed method - Yes.

Question Figure 321.25–A. the first 2 lines under the heading indicate, depending on the extent of the header with double or single portal frame, that the portal frame may have one or two portal frame panels (depending on width). Table 321.25-I footnote ‘g’ states the following braced wall panel conditions shall be permitted to be counted as one-half a braced wall panel toward meeting the required number of panels: (5) one PF panel complying with Figure 321.25-A. How do you count portal frame panels when determining how much bracing they provide towards meeting the minimum required amount?

Answer Intermittent bracing method: Per Table 321.25-I footnote ‘g’ a single narrow portal frame panel at one side of the opening counts as one-half a braced wall panel. A narrow portal frame panel at each side of the opening would count as one full braced panel.

Continuously Sheathed bracing method: Table 321.25-J indicates the minimum required total length of continuously sheathed panels and Figure 321.25-A indicates the minimum required width of a narrow portal frame panel dependent upon the total wall height. The actual width of the portal frame panel in feet (16-24” per the figure) counts towards the minimum required total length of continuously sheathed panels determined from Table 321.25-J.

Question 321.25(8)(c)6. This section allows balloon frame walls up to two floors in height but Tables 321.25-I and J do not permit extrapolation beyond 12’ wall height. Are braced wall panels allowed on a two floor balloon frame wall and if so how wide must the panels be?

Answer: Extrapolation is prohibited in Tables 321.25-I and J so the provisions may not be used on a building of an overall larger size and height than indicated in the bracing amount tables. Per SPS 321.25(8)(c)6. Balloon frame walls should be viewed as an exception for a portion of the overall structure not the whole building. If braced wall panels must be located on the balloon frame portion they shall have a maximum height to width ratio of 2.5:1.

Question Figure 321.25-B footnote ‘b’. Can you define what is meant by enclosed plan offsets and projections? Is a screen porch classified or defined as enclosed?

Answer There are definitions currently in the UDC that provide guidance on this topic:

SPS 320.07(59m) definition of a “Porch” means an unenclosed exterior structure at or near grade attached or adjacent to the exterior wall of any

building, and having a roof and floor.

SPS 320.07(10t) definition of a “Carport” means a structure used for storing motorized vehicles that is attached to a dwelling and has at least 2 sides completely unenclosed. Carports are specifically exempted as are open structures such as decks. A deck is a porch without a roof. A screen porch with no enclosing walls of any height and no other construction other than the structural members necessary to support the roof and the screen itself will be considered an open structure that can be excluded from the rectangle.

- Question Figure 321.25-B. Do rectangles have to abut at a wall line? Can it be a 100% interior wall line? How do you draw rectangles for homes with segments constructed at an angle or an attached garage at an angle to the dwelling? Generally speaking, yes, you want adjacent rectangles to abut at a common wall line which will be at least partially or may be entirely an interior wall line. It is permissible for rectangles to overlap but this may result in more bracing being required than if the rectangles did not overlap.
- Answer The code includes diagrams of homes with portions of the home constructed at an angle and provide a method for calculating the amount of bracing which can be attributed to a rectangle side by an angled wall segment.
- Question Tables 321.25-H, I and J. If a dwelling has varying wall heights, wind exposure categories, opening heights, etc. on each rectangle side how are the requirements and Tables to be applied? Are the most restrictive requirements applied to the entire building, to each rectangle, each rectangle side or to each braced wall panel?
- Answer It depends on the requirement being considered. The prescriptive requirements are a simplified method which attempt to strike a balance between practicality, simplicity and ease of use versus specificity and complexity.

Tables 321.25-I and J Bracing Amounts:

When applying these tables you must use the most restrictive variables for wall height and floor levels for the rectangle being considered. If the wall heights and number of floor levels vary an alternative would be to draw the rectangles differently so that each rectangle encompasses constant conditions.

For wind exposure category you could have and use different wind exposure categories for each wind direction or use the most restrictive or worst case wind exposure when evaluating the required bracing in both orthogonal (perpendicular) directions.

For eave to ridge height it should be determined using the roof structure

located on the portion of the building with the greatest number of floor levels (i.e. highest walls).

Table 321.25-H:

For braced panels located in walls of differing heights and with openings of differing heights the braced wall panel limitations are based on the context of its location and immediately surrounding conditions. So the minimum width of a braced wall panel may be determined based on the wall height and opening height where it is located.

- Question Tables 321.25-I and J. On a dwelling with varying number of stories, roof bearing elevations and roof heights, what eave to ridge distance must I use when applying the bracing amount tables?
- Answer Generally, the most restrictive variables for the entire rectangle must be used when applying Tables 321.25-I and J to determine the required bracing amounts. The eave to ridge height of the roof with the highest roof bearing elevation and greatest number of floor levels must be utilized when applying the bracing tables. An alternative would be to draw additional rectangles for portions of the dwelling with fewer floor levels and lesser eave to ridge height.
- Question Tables 321.25-I and J. Are bonus rooms considered another floor level when applying the bracing amount tables? Do the walls associated with roof dormers create an additional floor level when applying the tables?
- Answer No, a bonus room contained wholly within an attic truss does not create an additional floor level when applying the bracing amount tables if limited per Footnotes J to Tables I and J to a maximum 20' top of wall to ridge height and maximum 48" wall opening height as created by a dormer.
- Question Table 321.25-J, Eave-to-Ridge Height (feet) column. Should the numbers read, "0- 10, 10-15, 15-20" or do you have to interpolate values for, say a 12-foot roof or an 18-foot roof?
- Answer Per table footnote 'a' interpolation shall be permitted when using the table but is not required. If interpolation is not used, then if the eave to ridge height falls between two of the rows, the next highest value/row for eave to ridge height must be used. For example, if the eave to ridge height is 12', the row for eave to ridge height of 15' must be used to determine the required length of bracing.
- Question Figure 321.25-C. Where does the 21-foot spacing begin and end with a portal frame?
- Answer Per Figure 321.25-A, a portal frame, whether consisting of one or two narrow panels, has a maximum opening dimension of 18' and therefore will

automatically comply with the 21' spacing requirement. If only one side of the opening has a narrow panel, the opposite side is required to be either a wood structural panel (WSP), if using the intermittent method, or a continuously sheathed wood structural panel (CS-WSP), if using the continuous method. Then, at the outer extent of the portal frame figure, whether it is a narrow panel or standard braced wall panel, you measure the 21' away from portal frame from the outside edge of the panel in the figure to the outside edge of the next nearest panel.

321.25(8)(b) Allowable Holes in Braced Wall Panels

Footnote e to Table 321.25-G allows a hole in a panel as follows. Holes are not allowed in the hatched areas:

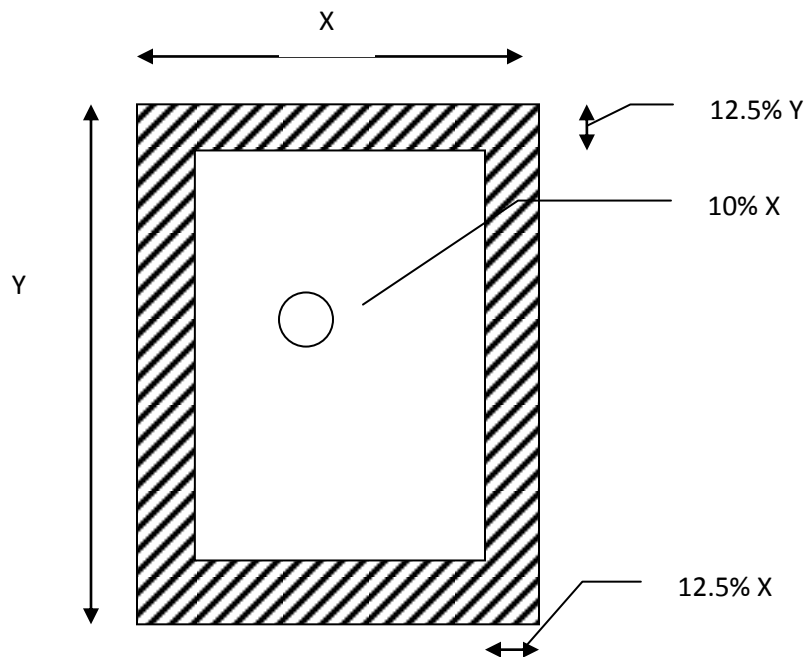

321.26(8) Flashing of Masonry Walls

Note that s. 321.24(3)(d)3. requires masonry sills to be flashed.

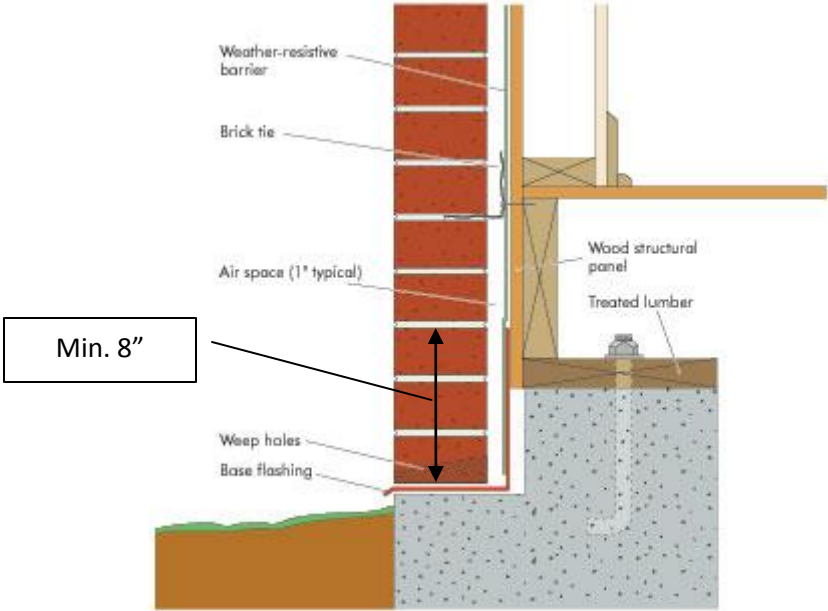
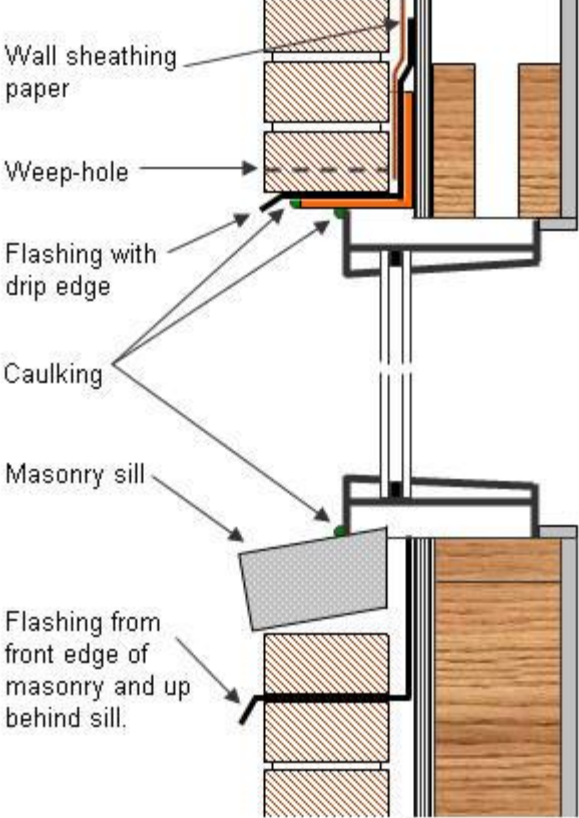

Subchapter VIII—Roof and Ceilings

321.27(1)(c) Sloped Roof Snow Loads

This section allows reduction of snow loads on roofs sloped more than 30 degrees. This means a reduction may be taken on roofs with greater than a 7:12 slope. This reduced design snow load may be transmitted down through the structure including any headers or beams. (See table below for examples.)

However, it must be remembered that s. SPS 320.02 also requires a 20 PSF wind load acting on the vertical roof projection.

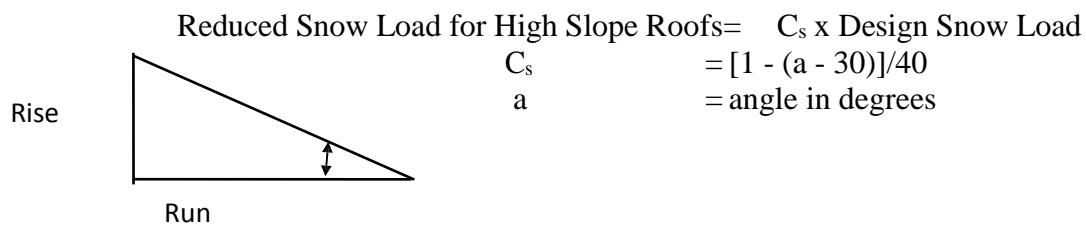

$$\text{Rise/Run} = \text{Slope} = \tan a$$

$$\text{Arctan}(\text{slope}) = a$$

Slope	a (degrees)	Zone 1 PSF	Zone 2 PSF
7/12	30	40	30
10/12	40	30	22.5
12/12	45	25	18.8
14/12	50	20	15

321.27(2) Resistance to Horizontal Wall Thrust from Rafters

Sloping roof rafters will push their supporting walls outward unless this force is properly resisted. Collar ties, which are required in the upper one-third of the rafter, provide some fixity of in the joining of the upper rafter ends, but do not provide much resistance to outward wall thrust. Typically the horizontal wall thrust needs to be resisted by wall ties or ceiling joists or by a ridge beam sized to carry half of the rafter loads.

321.28(6) Reroofing

Question: Can re-roofing be done without removing the existing layers of roofing?

Answer: The subject of the number of layers of roofing materials that can be placed now onto an existing roof system is now addressed in the dwelling code specifically and limited to

321.28(6)

two [one new layer on top of one existing layer]. However, the design loads of the roof rafter or trusses should not be exceeded. The span tables in the UDC assume dead loads that will typically allow a total of two lightweight roof layers. Additionally, the installation of the roof covering materials would have to be in accordance with the installation requirements.

321.28(7) Flashing of Chimneys

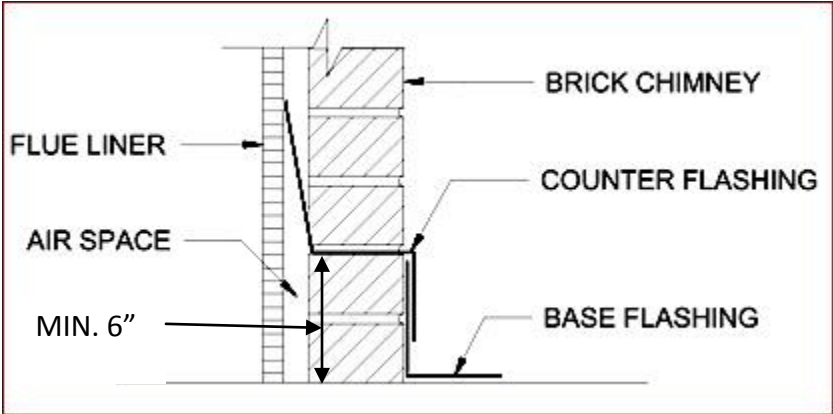

321.28(7) Chimney Cricket

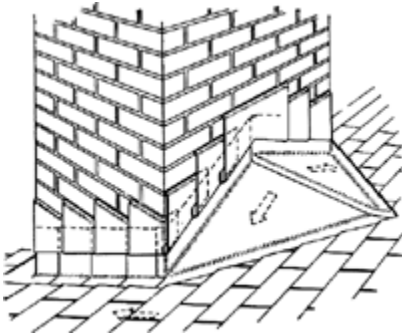

Subchapter IX — Fireplace Requirements

321.29 Masonry Fireplaces

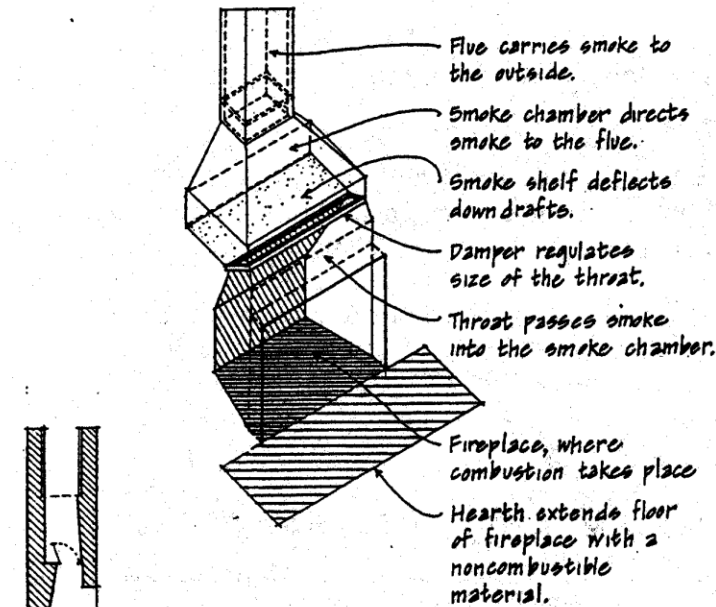

- A fireplace should be designed and constructed to:
- Sustain the combustion of the fuel
 - Draw properly to carry smoke and other combustible by-products to the outside
 - Radiate the maximum amount of heat comfortably into the room
 - Ensure proper distances from combustible materials.

Thus the dimensions and proportions of a fireplace and its flue, and the arrangement of its components, are subject to the laws of nature and the requirements of the building and mechanical codes.

The table below provides typical dimensions for three types of fireplaces.

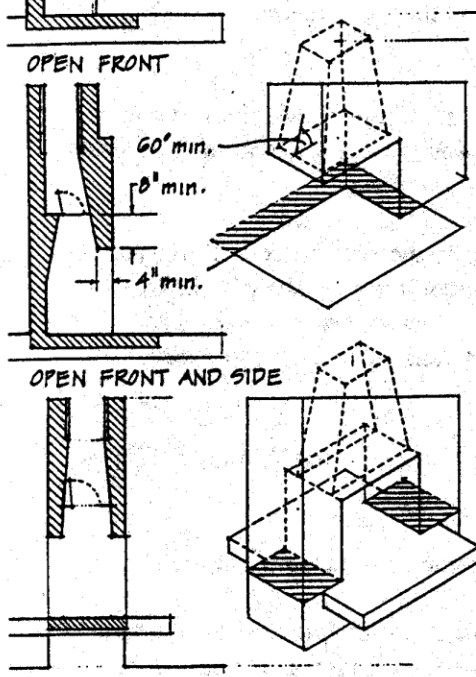

TYPICAL FIREPLACE DIMENSIONS (inches)

Width (A)	Height (B)	Depth (C)	Back width (D)	Vertical back (E)	Smoke chamber (F)	Damper width (G)	Flue size *
OPEN FRONT							
24	24	16	11	14	19	32	8 x 12
28	24	16	15	14	21	36	8 x 12
32	29	16	19	14	24	40	12 x 12
36	29	16	23	14	27	44	12 x 12
42	32	16	29	14	32	50	16 x 16
48	32	18	33	14	37	56	16 x 16
54	37	20	37	16	45	60	16 x 16
60	40	22	42	16	45	72	16 x 20
72	40	22	54	16	56	84	20 x 20
OPEN FRONT AND SIDE							
28	24	16	/				12 x 12
32	28	18					12 x 16
36	30	20					12 x 16
48	32	22					16 x 16
OPEN FRONT AND BACK							
28	24	16	/				12 x 12
32	28	16					12 x 16
36	30	17					12 x 16
48	32	19					16 x 16

OPEN FRONT AND BACK
Multifaced fireplaces are especially susceptible to drafts in a room; avoid placing their openings opposite an exterior door.

*Flue sizes exceed code minimums of SPS 321.29(1), which control.

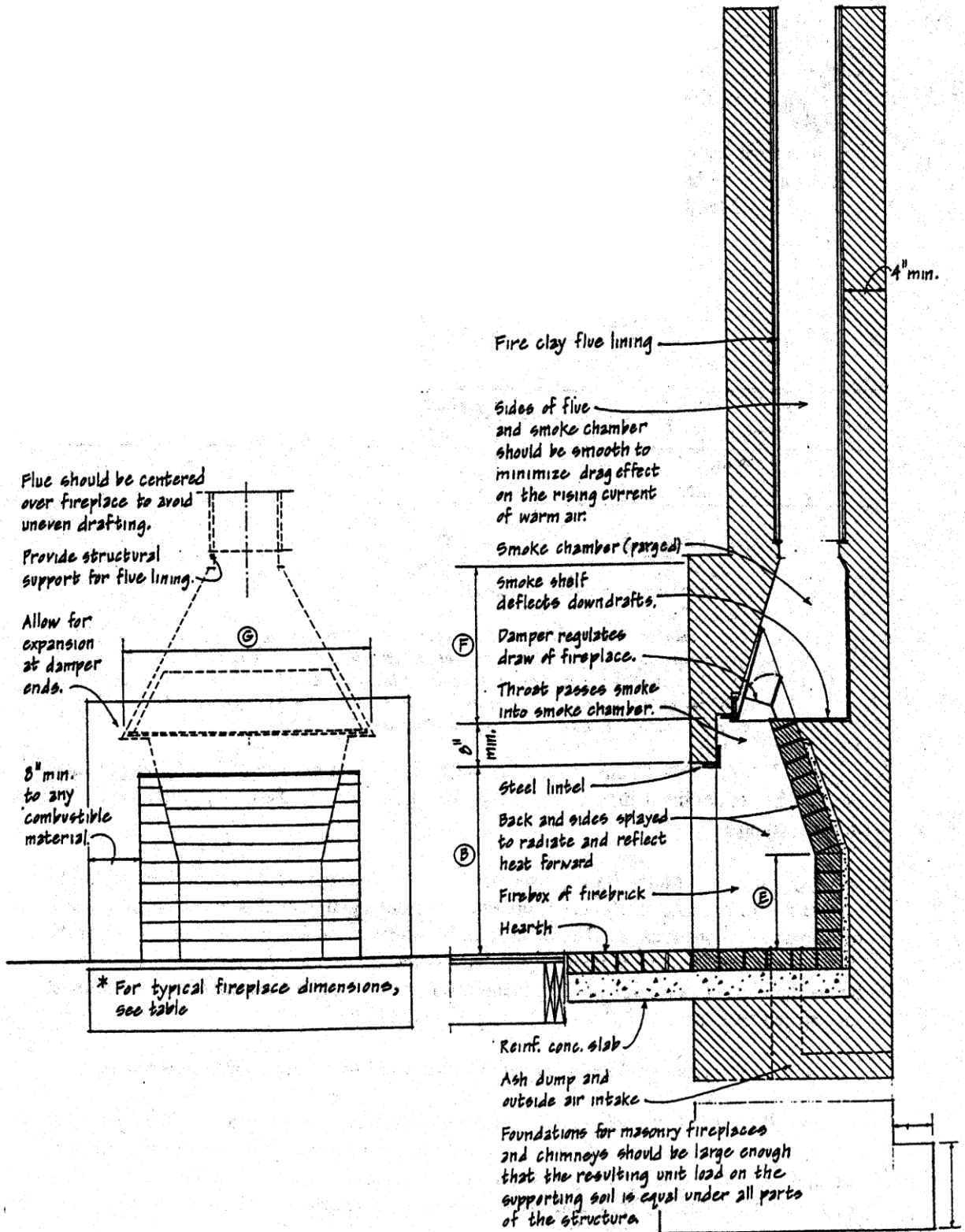

321.29(6) Hearth Extension

Question: How is the hearth extension measured?

Answer: The hearth or hearth extension is measured from the face of the fireplace opening and not from the front of the firebox, spark screen, or glass doors. The face of the fireplace includes any trim materials provided on the front of the fireplace. Earlier editions of the UDC permitted measurement from the firebox, but as of the 1989 Edition, the measurement is to be taken from the face of the fireplace opening.

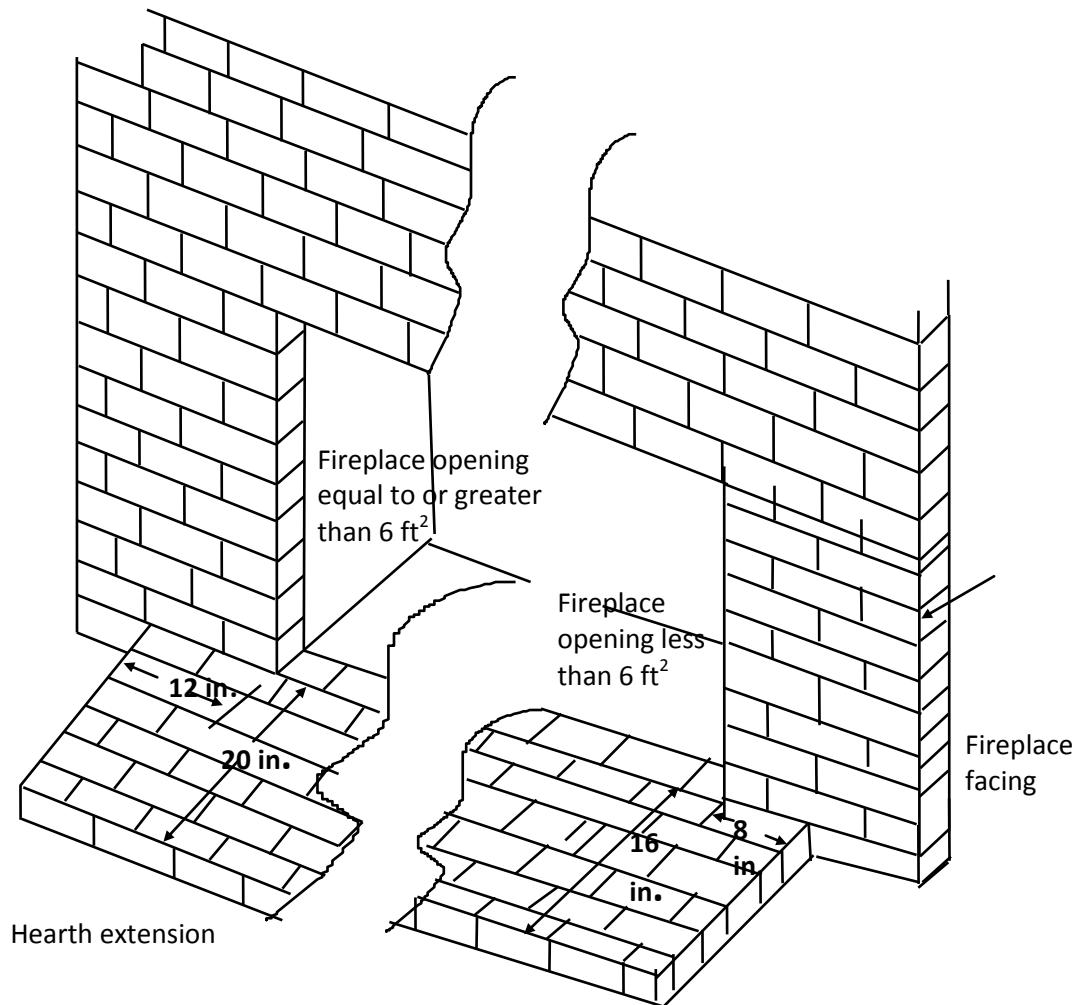

Fireplace hearth extension requirements

321.29(12) Framing Around Fireplaces

Question: This section refers to 321.30(9) which requires 2-inch clearances from fireplace masonry to combustibles. In some cases, the block and brick may cover an entire wall. In such a case, is it necessary to maintain the 2-inch clearance from the entire wall?

Answer: Because of the expected heat dissipation in such an installation, the department will accept the ends of the beams and headers to be placed without a 2-inch clearance if at least 12 inches of solid masonry is also provided between the member and the firebox or chimney flue. If the wood structural member is supported in the masonry, it must be fire cut or a self-releasing device must be used as required by s. SPS 321.26(9)(c).

Note the requirement for clearances to a fireplace applies only to framing. Other combustible elements such as mantles, trim, and flooring would need to comply with the s. SPS 321.29(11), as well as the hearth requirements of s. SPS 321.29(6).

321.30(7) Flue Liners

Question: If a stainless steel flue liner is used, what gauge stainless steel may be used to line a masonry chimney?

Answer: Stainless steel of 22 gauge or thicker is acceptable.

321.30(9) Fireblocking of Chimneys

Question: The Uniform Dwelling Code requires 2 inches of clearance between combustible headers, beams, rafters, joists and studs and the outside face of an interior chimney (1 inch for an exterior chimney). Does subs. SPS 321.085(1) on fire separation also apply where this rule states "holes around ducts and pipes shall also be fireblocked"?

Answer: Yes. It is the intent for SPS 321.085(1) and 321.30(9)(a) to apply to the 2-inch or 1-inch clearance between the chimney and the structural members. Noncombustible fire blocking material must be used

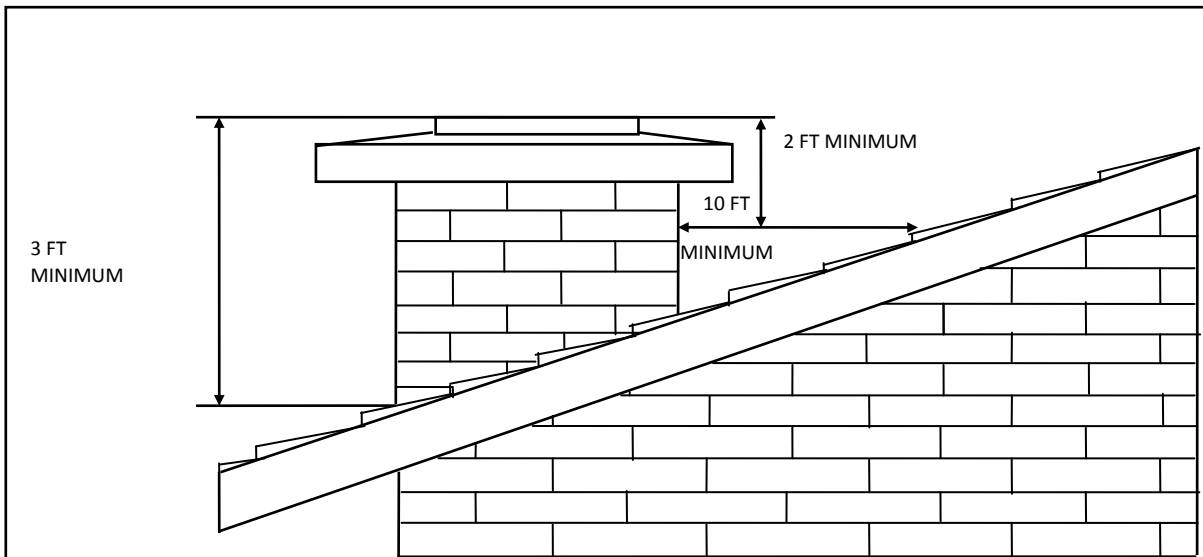

323.11(2)(a) Masonry Chimney Termination

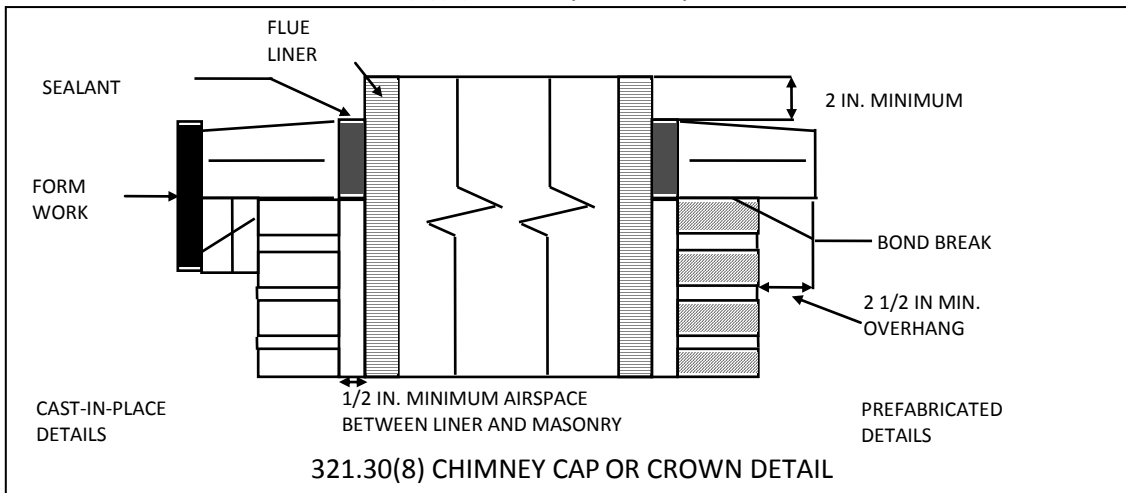

321.30(8) CHIMNEY CAP OR CROWN DETAIL

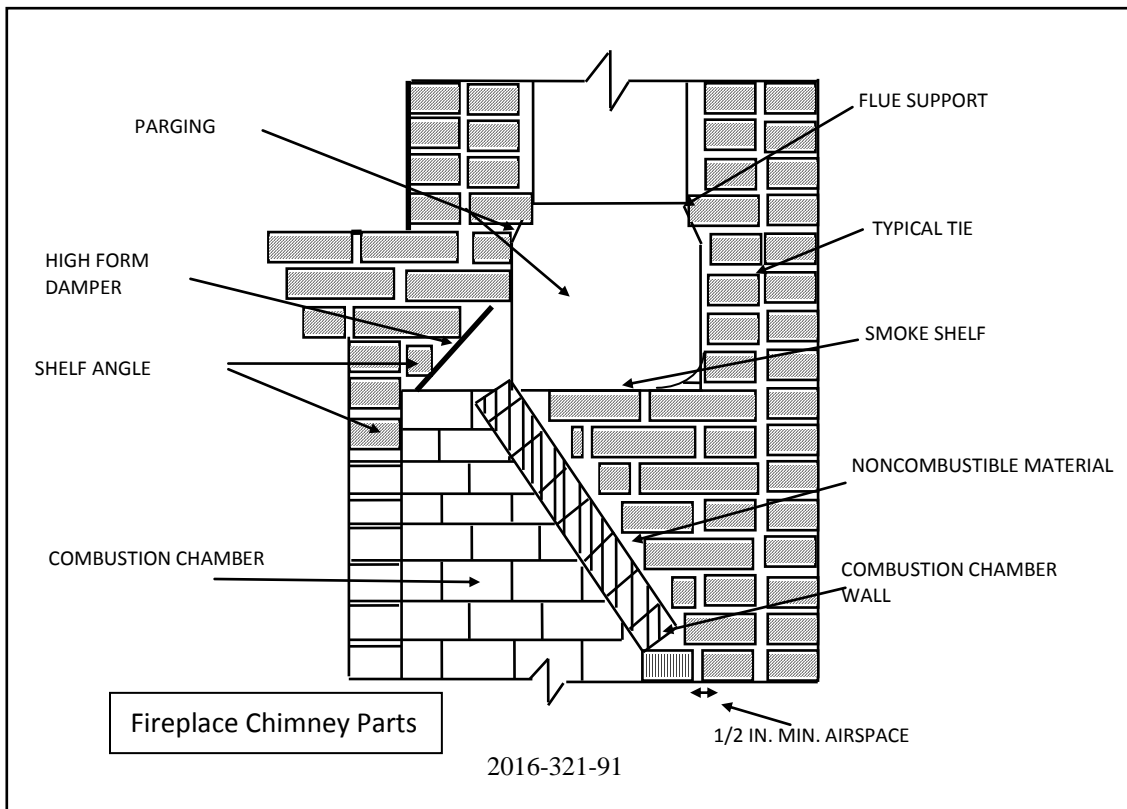

321.32 Factory-Built Fireplaces

Factory-built fireplaces (which use solid fuel) and their specified chimneys shall be tested and listed by a nationally recognized testing laboratory. Furthermore, the fireplace assembly and chimney shall be erected and maintained in accordance with the conditions of the listing. Currently acceptable testing and listing laboratories for this and other purposes are listed below. Not all will test all classes of appliances.

- Underwriter's Laboratories (UL)
- Electrical Testing Labs of New York (ETL-NY)
- Energy Testing Labs of Maine (ETL-MAINE)
- Canadian Standards Association (CSA)
- Product Fabrication Service (PFS)
- Warnock Hersey

Specific emphasis should be placed on inspection of the construction gap between the front of the fireplace unit and the finish material or fascia. Most, if not all, manufacturers require the gap be filled with noncombustible caulk or equivalent. The fear, although not specifically verified by our investigation, is that hot gases or sparks can migrate out of the fire box through such an opening and eventually cause ignition of the unprotected combustibles behind the fascia. Improper drafting could increase the likelihood of such an occurrence.

Typically the crack between the fireplace and hearth must also be properly sealed against entry of sparks and coals if there is combustible flooring below.

The use of any add-on items should be closely checked as to whether they are listed for that particular fireplace. Be especially suspicious of retrofitted stoves or fireplace inserts which can cause severe problems if the fireplace was not designed for them.

Also, fireplace doors should be checked to verify that they are of a type made by the fireplace manufacturer and approved for installation on that model. Oversize doors could restrict combustion air supply, block air circulation vents or slots that cool the unit or even deflect heat or hot gases laterally into the construction gap between the front of the unit and the surrounding fascia as described above.

In conclusion, all manufacturer's installation requirements should be followed. An inspector is entitled to request a copy of manufacturer's installation instructions, per s. SPS 320.09(4)(b), in order to conduct proper inspections.

Question: Many pre-manufactured fireplace installation instructions require a noncombustible insulating material be placed between the hearth extension finish material and the combustible floor. Is this noncombustible insulating board required by the UDC?

Answer: Indirectly, yes. Section SPS 321.32(1) requires the entire fireplace installation be installed per the manufacturer's listing. The hearth extension design is part of the listing. The insulating board specifications vary between fireplace manufacturers. For example, some require that the material should be equal to 3/4-inch thick

noncombustible insulating material with a thermal conductivity of $k = 0.55$ (Btu)(in)/(hr)(sqft)(°F). As an alternative to k-value, a 3/4-inch noncombustible material with a thermal conductance $C = .73$ or thermal resistance $R = 1.36$ is acceptable.

321.32 Gas Fireplaces

Question: Are gas-only fireplaces required to have a hearth extension per the UDC?

Answer: No. Gas-only fireplaces are covered by s. SPS 323.04 as a gas appliance and need to be installed per their listing, which typically may not require a hearth extension.

321.32 Factory-Built Fireplace Chimneys

Question: Does the requirement of s. 323.045(3)(a)1., that factory-built chimneys be tested to 2,100°F ("high-temperature" rated) if connected to a solid-fuel appliance, apply to a factory-built fireplace?

Answer: No. Section 323.045 applies to solid-fuel appliances other than those covered by other sections of the code such as masonry and factory-built fireplaces (ss. SPS 321.29 through 321.32). The proper chimney for a factory-built fireplace is the one it was tested and listed with and is normally shipped with the unit. It is possible that such listed fireplace assemblies will have a lower temperature chimney.

Subchapter X – Construction in Floodplains

This is the only place in the UDC that licensed architect or professional engineer can be required by code language to verify code is met [all other code compliance calculations may be accepted from non-licensed persons, but for this it must be from licensed persons].

Subchapter XI—Installation of Manufactured Homes

321.40 Manufactured Homes

The manufacture date of the manufactured home is key to the installation standards that it must follow, as well as the edition of the electrical code and other codes governing the interior of that home. However any site-constructed additions or foundations to such homes are covered by the current UDC, as noted in SPS 320.04(5)(b) that would require the new home placed on an existing foundation to have that foundation need to be UDC inspected and brought up to current UDC code minimums.

For older manufactured homes being installed on a new site and foundation, SPS 321.40(2) gives two options. First they can install it per the requirements in effect at the time the manufactured home was produced - this is per the manufacturer's installation instructions that are typically similar to the post April 1, 2007 homes method. The second option is to install on piers per the 17 minimum requirements of SPS 321.40(2)(b).

321.40

Decks and stoops serving manufactured homes may be designed per the requirements of the UDC itself or per the Appendices B & C methods. Per 321.15(2), small structures such as stoops, that provide a door landing, may be supported by properly designed means other than frost-depth footings, if isolated from the manufactured home. This could include grade level concrete blocks of at least 3-1/2" thickness, as allowed in Appendix B for short deck stair stringers. Per SPS 321.15(3)(b), all organic soil shall be removed below the block and replaced with compacted granular material. A drop, not exceeding 8" per SPS 321.04, from the home to the landing is suggested to avoid blockage of the doorway if there were frost heave of the landing. Note that attachment of adjacent structures to a manufactured home is only acceptable per the home manufacturer's acceptance.

Manufactured Home Foundation Requirements

Manufactured Home Production Date	Home on Piers (supported by individual footings or a slab)	Home on Basement or Crawlspace	Additions to Home
Pre June 1, 1980	s. SPS 321.40(2) <ul style="list-style-type: none"> • No anchorage required • No footings below frost depth or frost protection required 	Per any municipal requirements relating to basements or crawlspaces for a pre-June 1, 1980 dwelling	Per any municipal requirements relating to additions to a pre-June 1, 1980 dwelling
June 1, 1980 through March 31, 2007	s. SPS 321.40(2) <ul style="list-style-type: none"> • No anchorage required • No footings below frost depth or frost protection required 	Per UDC general requirements: <ul style="list-style-type: none"> • Anchorage of home to basement or crawlspace required • Footings of basement or crawlspace below frost depth or frost protected 	Per UDC general requirements: <ul style="list-style-type: none"> • Anchorage of addition to its foundation required • Footings of addition below frost depth or frost protected (see s. SPS 321.15(1)(e) regarding "floating" structure if home is not supported on frost-protected
On or after April 1, 2007	s. SPS 321.40(1) <ul style="list-style-type: none"> • Including anchorage • Footings & foundations – Per: <ul style="list-style-type: none"> • 24 CFR Part 3285 • Or UDC with 48" minimum depth • Or WHA Manufactured Home Frost-Protected Foundation Design – WI DSPS Approval# FN 20129031 	Per UDC general requirements: <ul style="list-style-type: none"> • Anchorage required • Footings below frost depth or frost protected 	Per UDC general requirements: <ul style="list-style-type: none"> • Anchorage required • Footings below frost depth or frost-protected