

FOR CONSTRUCTION

Owner: Renovation Wranglers  
 102 E 26th St  
 Bryan, TX 77803  
 kate@renovationpros.com | 979.450.9969

ARCHITECTURE  
 Architect of Record: LKB Architecture  
 2929 Allen Pkwy Suite 200  
 Houston, TX 77019  
 isa@lkbarchitecture.com | 713.425.3076

STRUCTURAL: Dudley  
 Firm # 18677  
 6102 Imperial Loop Drive  
 College Station, TX 77845  
 Bunes, TX 78611  
 oolika@dudleyeng.com | (979) 777-0720

MEP: AMC Engineers  
 Texas Firm #9441  
 508 E Jackson St # 552  
 Burnet, TX 78611  
 info@amcengineers.com | 512.535.6427

48  
S0.1  
STRUCTURAL - FOUNDATION  
1/4" = 1'-0"

SHEARWALL HOLDDOWN AT FOUNDATION						
TYPE MARK	TYPE	HARDWARE	END POST	ATTACHMENT TO END POST	ANCHORAGE TO FOUNDATION	CAPACITY
HD2	POST-INSTALLED HOLDDOWN	SIMPSON HTS	(2)-2X	(26) 0.148 X 3 NAILS	5/8" DIA. GR.36 ALL-THREAD WITH 8" EMBEDMENT WITH NUT AND WASHER	SEE SHEET S4.3 FOR DETAILS 4670
HD3	POST-INSTALLED HOLDDOWN	SIMPSON HDU8-SDS2.5	(3)-2X	(20) 1/4" X 2 1/2" SDS SCREWS	7/8" DIA. GR.36 ALL-THREAD WITH 17 1/2" EMBEDMENT WITH NUT AND WASHER	SEE SHEET S4.3 FOR DETAILS 6200
HD4	CAST IN PLACE	SIMPSON HDU14-SDS2.5	6X6	(36) 1/4" X 2 1/2" SDS SCREWS	1" DIA. GR.36 ANCHOR ROD WITH 18" EMBEDMENT	SEE SHEET S4.3 FOR DETAILS 10000

- STRUCTURAL CONNECTION NOTES:**
- MINIMUM EDGE DISTANCE TO CENTERLINE OF BOLT IS 3". AT CORNERS, THE OPPOSING EDGE DISTANCE MUST BE ≥ 6".
  - MINIMUM #4X36" LONG REINFORCING BAR LOCATED 3'-5" BELOW THE TOP OF THE SLAB IS REQUIRED TO BE CENTERED ON THE HOLDDOWN. AT CORNER, BEND THE BAR 90° AT THE CENTER.
  - REFERENCE MECHANICALLY LAMINATED BUILT-UP COLUMN FOR NAILING REQUIREMENTS FOR END POST.
  - SIMPSON ATR (REQUIRED Ø) WITH SIMPSON SET-3G IS AN ACCEPTABLE OPTION.

FOOTING SCHEDULE						
TYPE MARK	NAME	COUNT	WIDTH	LENGTH	DEPTH	TYPE COMMENTS
F1	CONCRETE STEEL COLUMN FOOTING - 4' X 4' X 2'-6"	9	4'-0"	4'-0"	2'-6"	SEE DETAIL 2B/S3.1 SEE DETAIL 2B/S3.1
F2	CONCRETE STEEL COLUMN FOOTING 5.5' X 5.5' X 2.5'	7	5'-6"	5'-6"	2'-6"	SEE DETAIL 2B/S3.1 SEE DETAIL 2B/S3.1

PTI PARAMETERS	
E <sub>m</sub> - CENTER	4.8'
E <sub>m</sub> - EDGE	2.0'
Y <sub>m</sub> - CENTER	1.0"
Y <sub>m</sub> - EDGE	1.25"
EFFECTIVE PLASTICITY INDEX	35
ALLOW. BEARING (PSF)	1,800 PSF
MIN. BEAM EMBEDMENT BELOW FINAL GRADE	18"
MIN PERIMETER BEAM EMBEDMENT BELOW FINAL GRADE	52"

SLAB GEOMETRY	
AREA (SF)	5711 SF
PERIMETER (FT)	394 FT
SHAPE FACTOR (PERIMETER <sup>2</sup> /AREA)	27.5

FOUNDATION SCHEDULE							
BEAM ID	DESCRIPTION	WIDTH	DEPTH	TOP BARS	BOTTOM BARS	STIRRUPS	COMMENTS
GB1	GRADE BEAM - INTERIOR - 14"	14"	30"	(3) - #6	(3) - #6	#3 @24" OC	
GB2	VERTICAL MOISTURE BARRIER	14"	30"	(3) - #6	(3) - #6	#3 @24" OC	
GB3	GRADE BEAM - INTERIOR - 28"	28"	30"	DOUBLE GB1	DOUBLE GB1	DOUBLE #3	(2) GB1 STIRRUP CAGES SIDE/SIDE - SEE DETAIL 2A/S3.0
GB4	8" CONCRETE FOUNDATION	8"	36"				SEE 6A/S3.1
GB5	TURNDOWN THICKENED SLAB	12"	12"	N/R	(2) - #4	N/R	SEE DETAIL 2C/S3.1
W1	8" CONCRETE (ARCHITECTURE FINISH) WALL	8"					SEE 1D/S3.1 FOR REINFORCING AND SIZE

**FOUNDATION NOTES**

FOUNDATION TYPE: BRAB TYPE III - STIFFENED NON-STRUCTURAL SLAB-ON-GROUND  
 SLAB THICKNESS: 5"  
 SLAB REINFORCEMENT: #4 @ 16" OC EACH WAY - REF DETAIL  
 DESIGN METHOD: ACI 318  
 VAPOR RETARDER: MINIMUM 15 MIL (UNLESS THICKER REQ'D BY ARCHITECT)

- NOTES:**
- BEAMS ARE TYPE B1 UNO.
  - LOCATE THE FIRST STIRRUP A MAXIMUM OF 3" FROM FACE OF SUPPORT.
  - BEAM DEPTH INDICATED IN THE SCHEDULE IS A STRUCTURAL MINIMUM THAT THE BEAM REINFORCEMENT CAGE MAY BE BASED UPON. REFERENCE GEOTECHNICAL REPORT FOR MINIMUM GRADE BEAM EMBEDMENT BELOW ADJACENT FINAL GRADE OR FLATWORK/PAVEMENT.
  - N/R = NOT REQUIRED

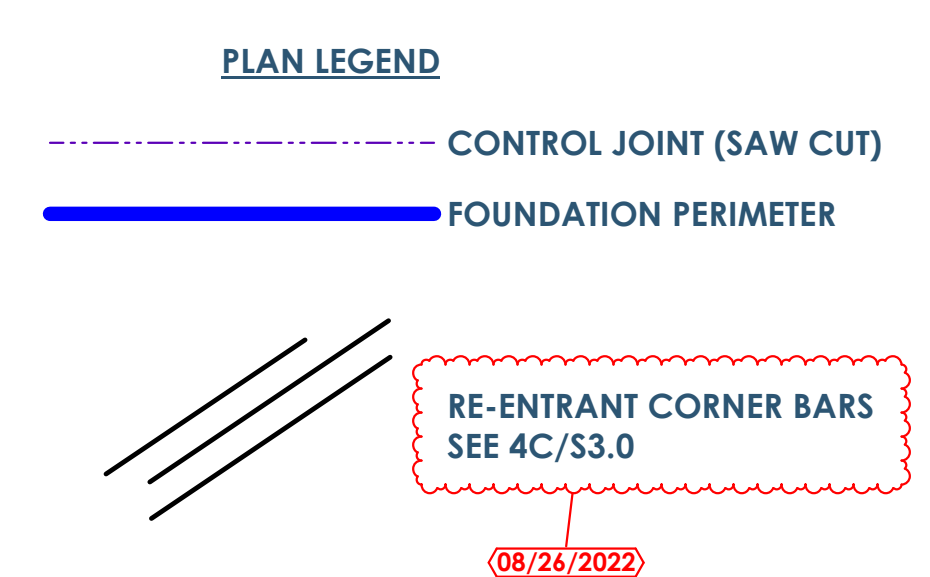

- PLAN NOTES**
- VERIFY ALL EDGE OF FOUNDATION DIMENSIONS WITH FINAL ARCHITECTURE FLOOR PLANS.
  - FORM DIMENSIONS, SLAB DROPS, SLOPES, ETC. SHOWN AS AN AID TO CONTRACTOR ONLY. VERIFY EXACT DIMENSIONS AND LOCATIONS WITH ARCHITECT.
  - DIMENSIONS ARE TO OF GRADE BEAMS OR EDGE OF SLAB UNLESS NOTED OTHERWISE.
  - CONTROL JOINTS (SAW-CUTS) ARE RECOMMENDED TO REDUCE CRACKS IN THE SLAB, BUT ARE NOT REQUIRED FOR STRUCTURAL REQUIREMENTS. FOR THE RECOMMENDED MAXIMUM JOINT SPACING, REFERENCE DETAIL.
  - FOR FLATWORK OR PAVEMENT ABUTTING THE BUILDING FOUNDATION REFERENCE DETAIL.
  - CONCRETE IS ASSUMED TO RECEIVE A STEEL TROWEL FINISH UNLESS NOTED OTHERWISE. NOTIFY ENGINEER IF ARCHITECTUALLY EXPOSED CONCRETE (STAINED, POLISHED, ETC.) IS PLANNED FOR ADDITIONAL SHRINKAGE CRACKING MITIGATION METHODS.

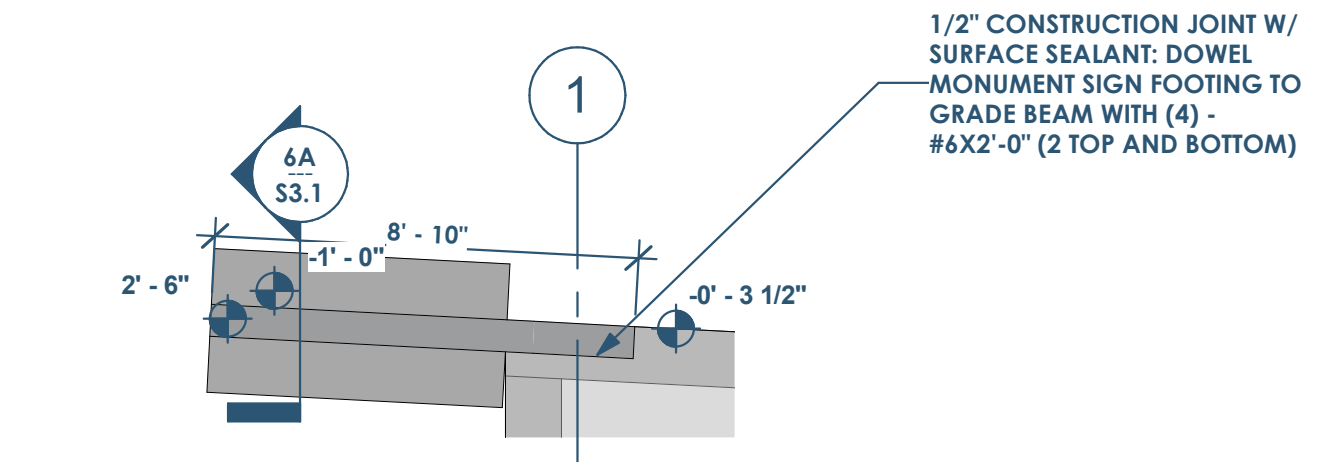

6A  
S0.1  
STRUCTURAL - FOUNDATION - SIGN AREA  
1/4" = 1'-0"

This project, like most OpeningDesign's projects, is open source (Attribution-ShareAlike 4.0 International-CC BY-SA 4.0)-freely available to any party for future use, assuming the terms such as Attribution and ShareAlike are honored.