

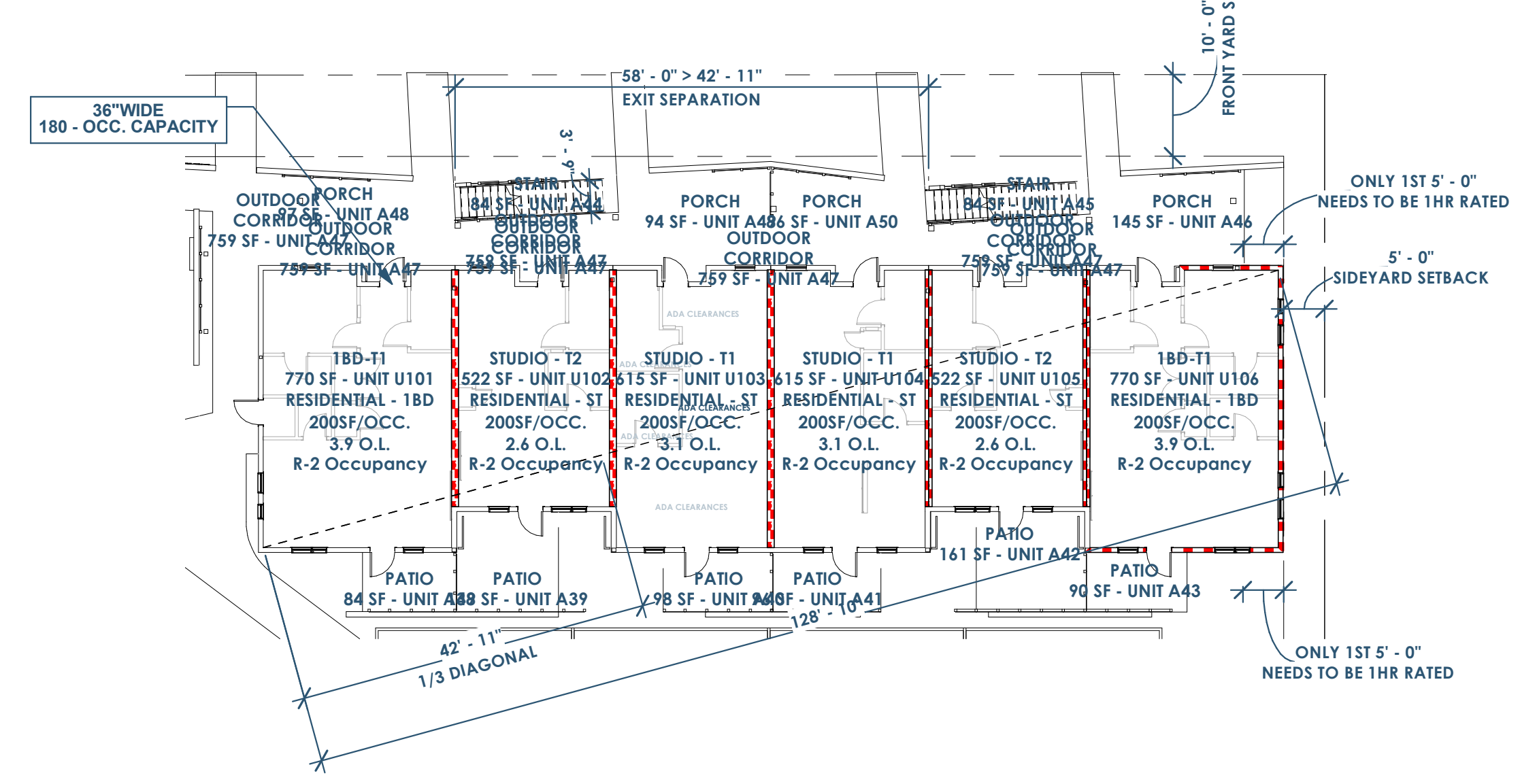

OCCUPANT LOAD (BASED ON TABLE 1004.1.2)						
Level	Name	Occupancy	Area	Function of Space	Area Allowance Per Occupant	Occupant Load
3RD FLOOR	OUTDOOR CORRIDOR	R-2	635 SF	CIRCULATION	200	3.2
3RD FLOOR	STAIR	R-2	84 SF	CIRCULATION	200	0.4
3RD FLOOR	STAIR	R-2	81 SF	CIRCULATION	200	0.4
3RD FLOOR	BALCONY	R-2	123 SF	RESIDENTIAL	200	0.6
3RD FLOOR	BALCONY	R-2	123 SF	RESIDENTIAL	200	0.6
3RD FLOOR	PORCH	R-2	224 SF	RESIDENTIAL	200	1.1
3RD FLOOR	PORCH	R-2	107 SF	RESIDENTIAL	200	0.5
3RD FLOOR	PORCH	R-2	101 SF	RESIDENTIAL	200	0.5
3RD FLOOR	PORCH	R-2	142 SF	RESIDENTIAL	200	0.7
3RD FLOOR	1BD-T1	R-2	770 SF	RESIDENTIAL - 1BD	200	3.9
3RD FLOOR	1BD-T1	R-2	770 SF	RESIDENTIAL - 1BD	200	3.9
3RD FLOOR	STUDIO - T1	R-2	618 SF	RESIDENTIAL - ST	200	3.1
3RD FLOOR	STUDIO - T1	R-2	618 SF	RESIDENTIAL - ST	200	3.1
3RD FLOOR	STUDIO - T2	R-2	525 SF	RESIDENTIAL - ST	200	2.6
3RD FLOOR	STUDIO - T2	R-2	525 SF	RESIDENTIAL - ST	200	2.6
3RD FLOOR: 15			5447 SF			27.2
2ND FLOOR	OUTDOOR CORRIDOR	R-2	613 SF	CIRCULATION	200	3.1
2ND FLOOR	STAIR	R-2	84 SF	CIRCULATION	200	0.4
2ND FLOOR	STAIR	R-2	84 SF	CIRCULATION	200	0.4
2ND FLOOR	BALCONY	R-2	123 SF	RESIDENTIAL	200	0.6
2ND FLOOR	BALCONY	R-2	123 SF	RESIDENTIAL	200	0.6
2ND FLOOR	PORCH	R-2	334 SF	RESIDENTIAL	200	1.7
2ND FLOOR	PORCH	R-2	107 SF	RESIDENTIAL	200	0.5
2ND FLOOR	PORCH	R-2	101 SF	RESIDENTIAL	200	0.5
2ND FLOOR	PORCH	R-2	142 SF	RESIDENTIAL	200	0.7
2ND FLOOR	1BD-T1	R-2	770 SF	RESIDENTIAL - 1BD	200	3.9
2ND FLOOR	1BD-T1	R-2	770 SF	RESIDENTIAL - 1BD	200	3.9
2ND FLOOR	STUDIO - T1	R-2	617 SF	RESIDENTIAL - ST	200	3.1
2ND FLOOR	STUDIO - T1	R-2	617 SF	RESIDENTIAL - ST	200	3.1
2ND FLOOR	STUDIO - T2	R-2	525 SF	RESIDENTIAL - ST	200	2.6
2ND FLOOR	STUDIO - T2	R-2	525 SF	RESIDENTIAL - ST	200	2.6
2ND FLOOR: 15			5537 SF			27.7
1ST FLOOR	OUTDOOR CORRIDOR	R-2	759 SF	CIRCULATION	200	3.8
1ST FLOOR	STAIR	R-2	84 SF	CIRCULATION	200	0.4
1ST FLOOR	STAIR	R-2	84 SF	CIRCULATION	200	0.4
1ST FLOOR	PATIO	R-2	84 SF	RESIDENTIAL	200	0.4
1ST FLOOR	PATIO	R-2	149 SF	RESIDENTIAL	200	0.7
1ST FLOOR	PATIO	R-2	98 SF	RESIDENTIAL	200	0.5
1ST FLOOR	PATIO	R-2	96 SF	RESIDENTIAL	200	0.5
1ST FLOOR	PATIO	R-2	141 SF	RESIDENTIAL	200	0.8
1ST FLOOR	PATIO	R-2	90 SF	RESIDENTIAL	200	0.4
1ST FLOOR	PORCH	R-2	145 SF	RESIDENTIAL	200	0.7
1ST FLOOR	PORCH	R-2	97 SF	RESIDENTIAL	200	0.5
1ST FLOOR	PORCH	R-2	94 SF	RESIDENTIAL	200	0.5
1ST FLOOR	PORCH	R-2	86 SF	RESIDENTIAL	200	0.4
1ST FLOOR	1BD-T1	R-2	770 SF	RESIDENTIAL - 1BD	200	3.9
1ST FLOOR	1BD-T1	R-2	770 SF	RESIDENTIAL - 1BD	200	3.9
1ST FLOOR	STUDIO - T1	R-2	615 SF	RESIDENTIAL - ST	200	3.1
1ST FLOOR	STUDIO - T1	R-2	615 SF	RESIDENTIAL - ST	200	3.1
1ST FLOOR	STUDIO - T2	R-2	522 SF	RESIDENTIAL - ST	200	2.6
1ST FLOOR	STUDIO - T2	R-2	522 SF	RESIDENTIAL - ST	200	2.6
1ST FLOOR: 19			5842 SF			29.2
Grand total: 49			18262 SF			84.1

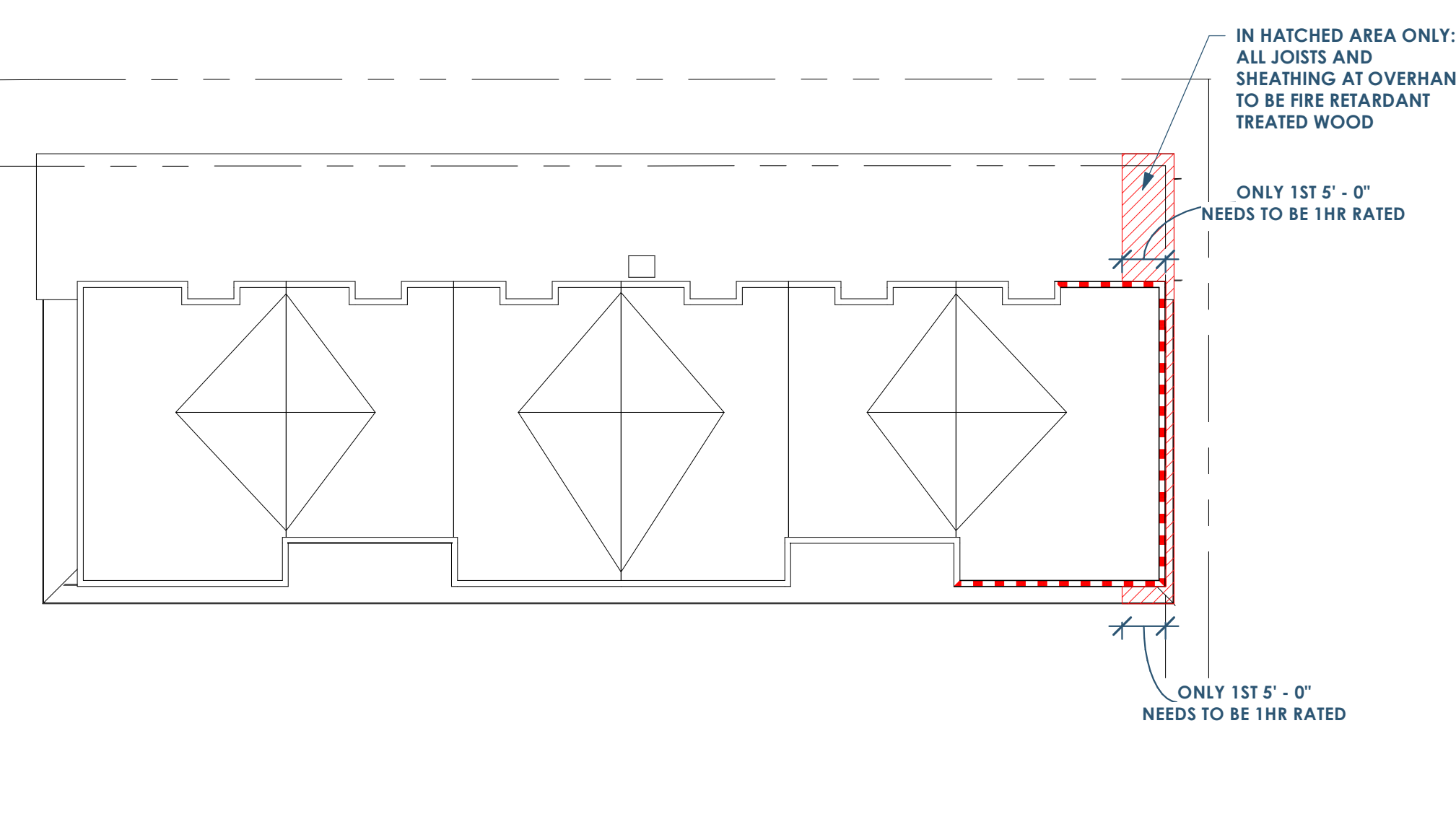

4B A001 LIFE SAFETY - 1ST FLOOR  
1/16" = 1'-0"



5 A001 LIFE SAFETY - ROOF  
1/16" = 1'-0"

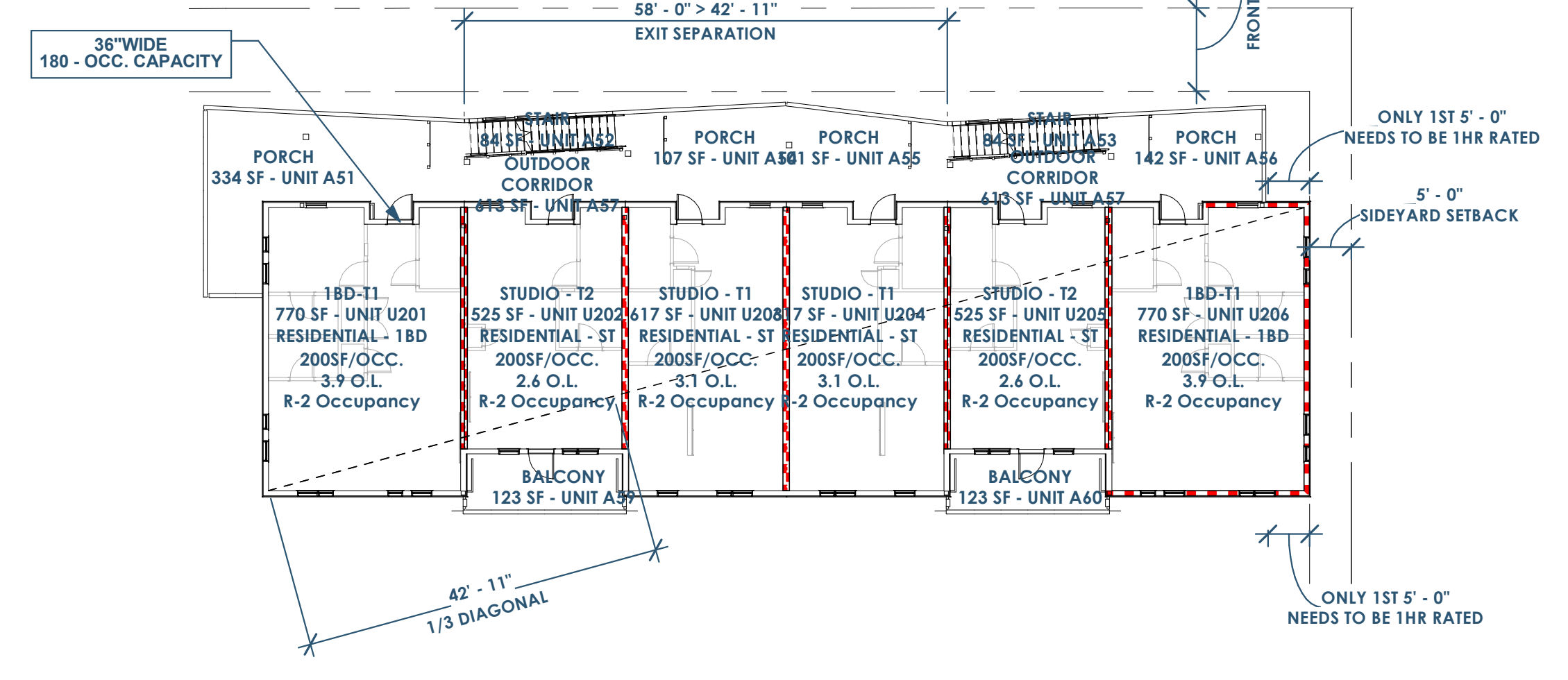

6C A001 LIFE SAFETY - 2ND FLOOR  
1/16" = 1'-0"

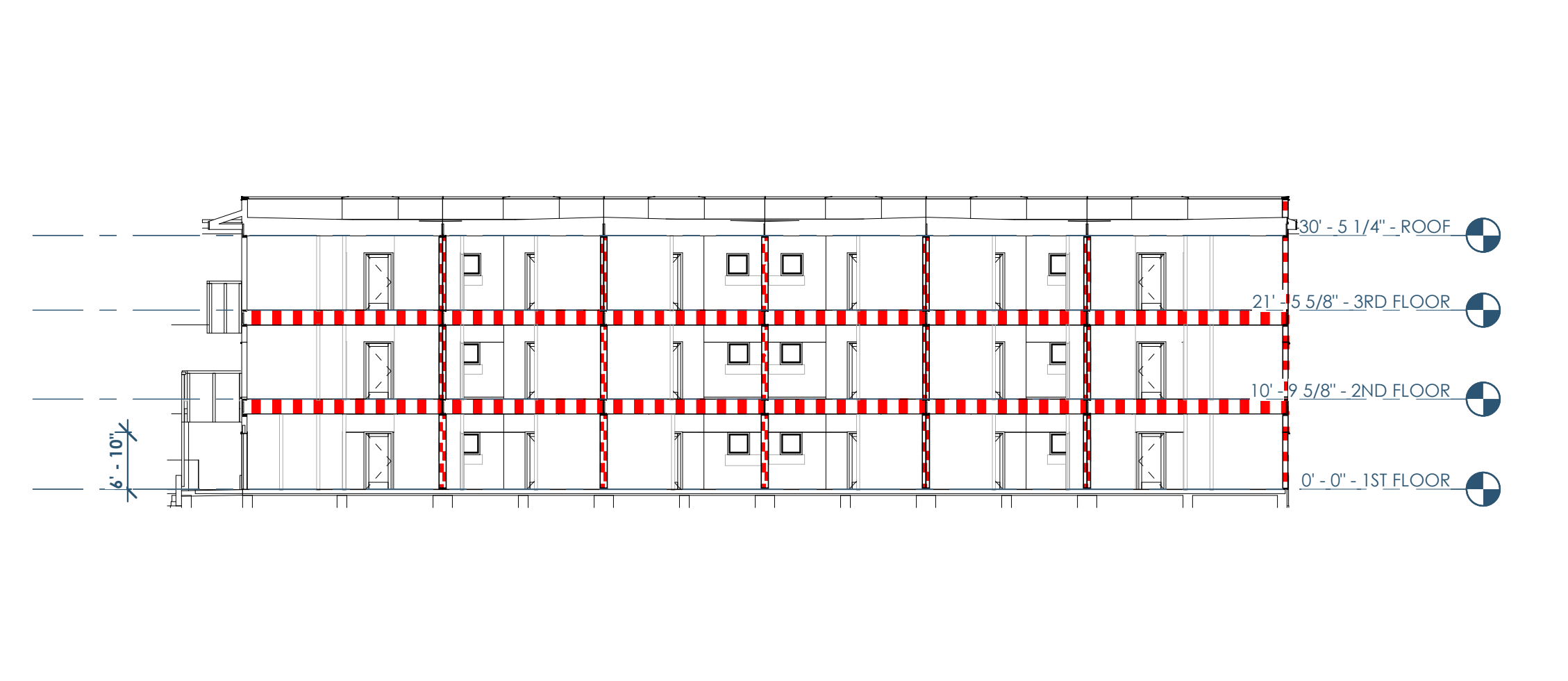

1 A001 LIFE SAFETY SECTION - EAST/WEST  
1/16" = 1'-0"

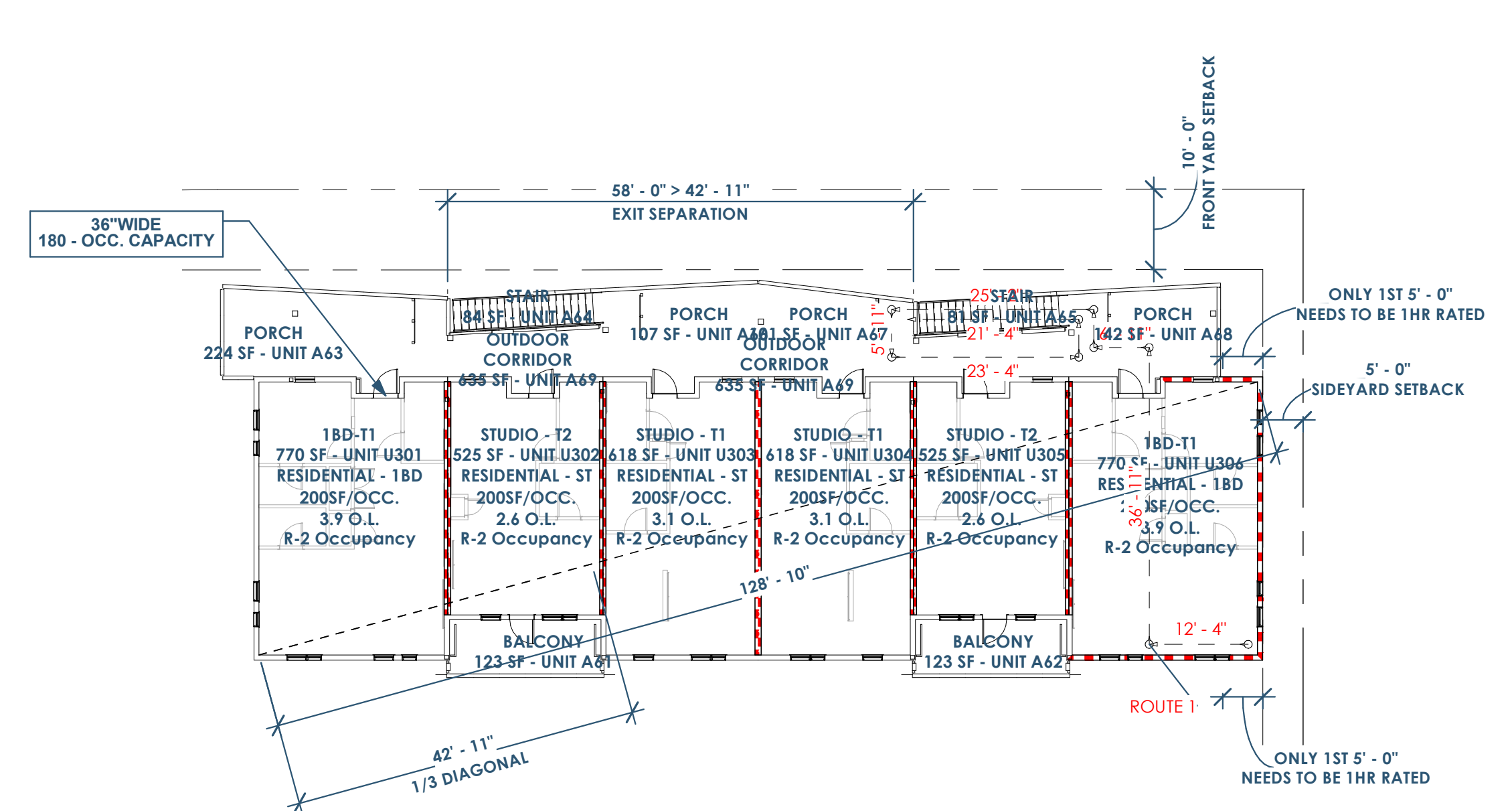

6A A001 LIFE SAFETY - 3RD FLOOR  
1/16" = 1'-0"

**RATED WALLS/FLOORS LEGEND**

- RATED - 4 HR
- RATED - 3 HR
- RATED - 2 HR
- RATED - 1.5 HR
- RATED - 1 HR
- RATED - 0.5 HR

**EGRESS DATA**

EXIT ROUTE	DISTANCE
ROUTE 1	141' - 4"

RENOVATION Wranglers  
Owner: Renovation Wranglers  
102 E 26th St  
Bryan, TX 77803  
Katherine@wranglers.com | 979.450.9969

ARCHITECTURE  
Architect of Record: UKB Architecture  
2929 Allen Pkwy Suite 200  
Houston, TX 77019  
isa@ukbarchitecture.com | 713.425.3076

MEP: AMC Engineers  
508 E Jackson St # 552  
Burnet, TX 78611  
info@amcengineers.com

This project, like most OpeningDesign's projects, is open source (Attribution-ShareAlike 4.0 International-CC BY-SA 4.0)-freely available to any party for future use, assuming the terms such as Attribution and ShareAlike are honored.

Date	Description
05.19.2022	Progress Set

openingdesign  
Architect: OpeningDesign  
17 S Fairchild | FL 7  
Madison, WI 53703  
ryan@openingdesign.com | 773.425.6456

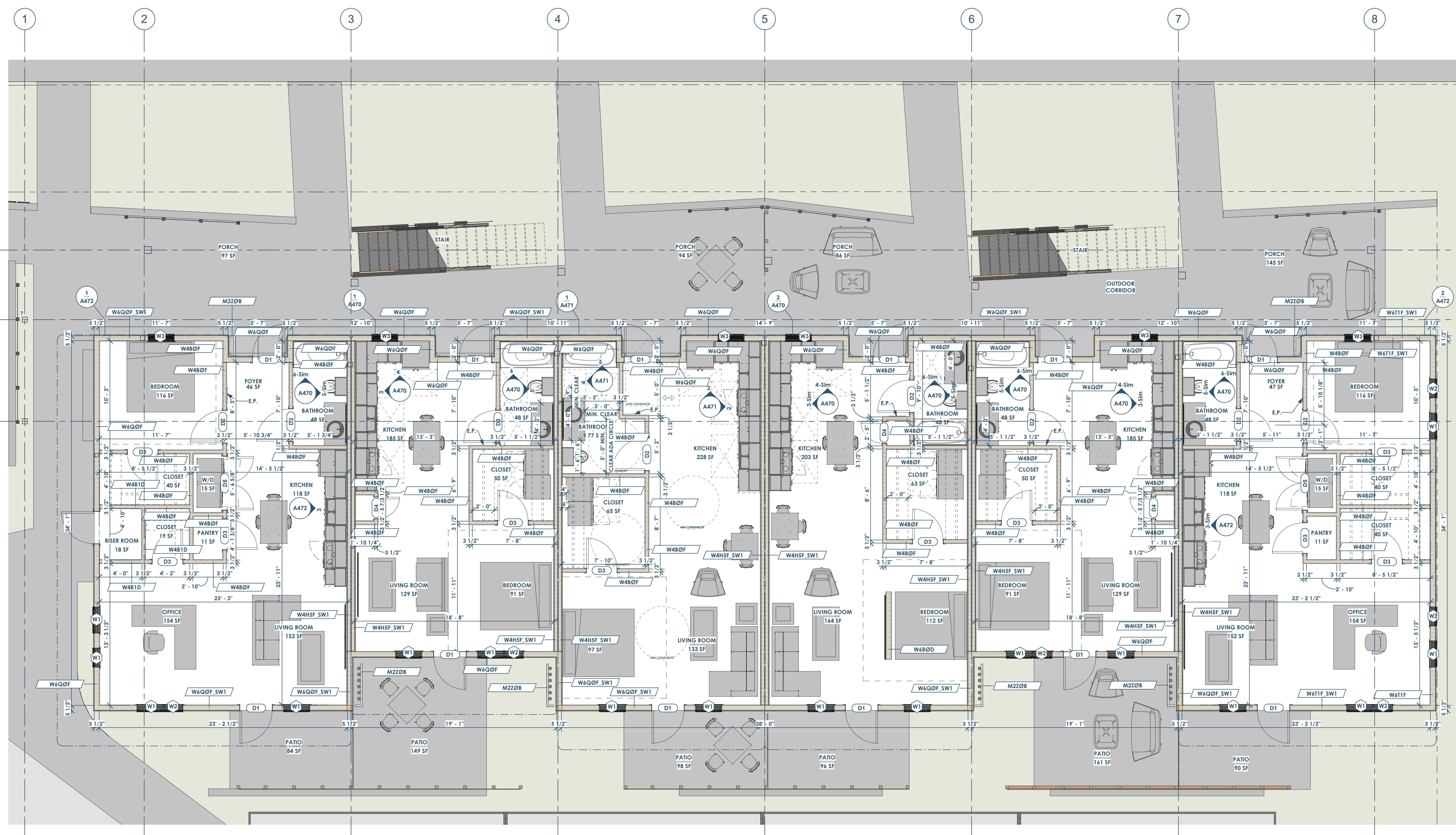

FLOOR PLAN - 1ST FLOOR  
1/4" = 1'-0"

This project, like most OpeningDesign's projects, is open source (Attribution-ShareAlike 4.0 International-CC BY-SA 4.0)-freely available to any party for future use, assuming the terms such as Attribution and ShareAlike are honored.

Date	Description
05.19.2022	Progress Set

RENOVATION  
Wranglers  
Owner: Renovation Wranglers  
102 E 26th St  
Bryan, TX 77803  
Katherine@wranglers.com | 979.450.9969

ARCHITECTURE  
Architect of Record: LKB Architecture  
2929 Allen Pkwy Suite 200  
Houston, TX 77019  
isa@lkbarchitecture.com | 713.425.3076

STRUCTURAL  
Structural: Dudley  
6102 Imperial Loop Drive  
College Station, TX 77845  
(979) 777-0720

MEP  
MEP: AMC Engineers  
508 E Jackson St # 552  
Burnet, TX 78611  
info@amcengineers.com

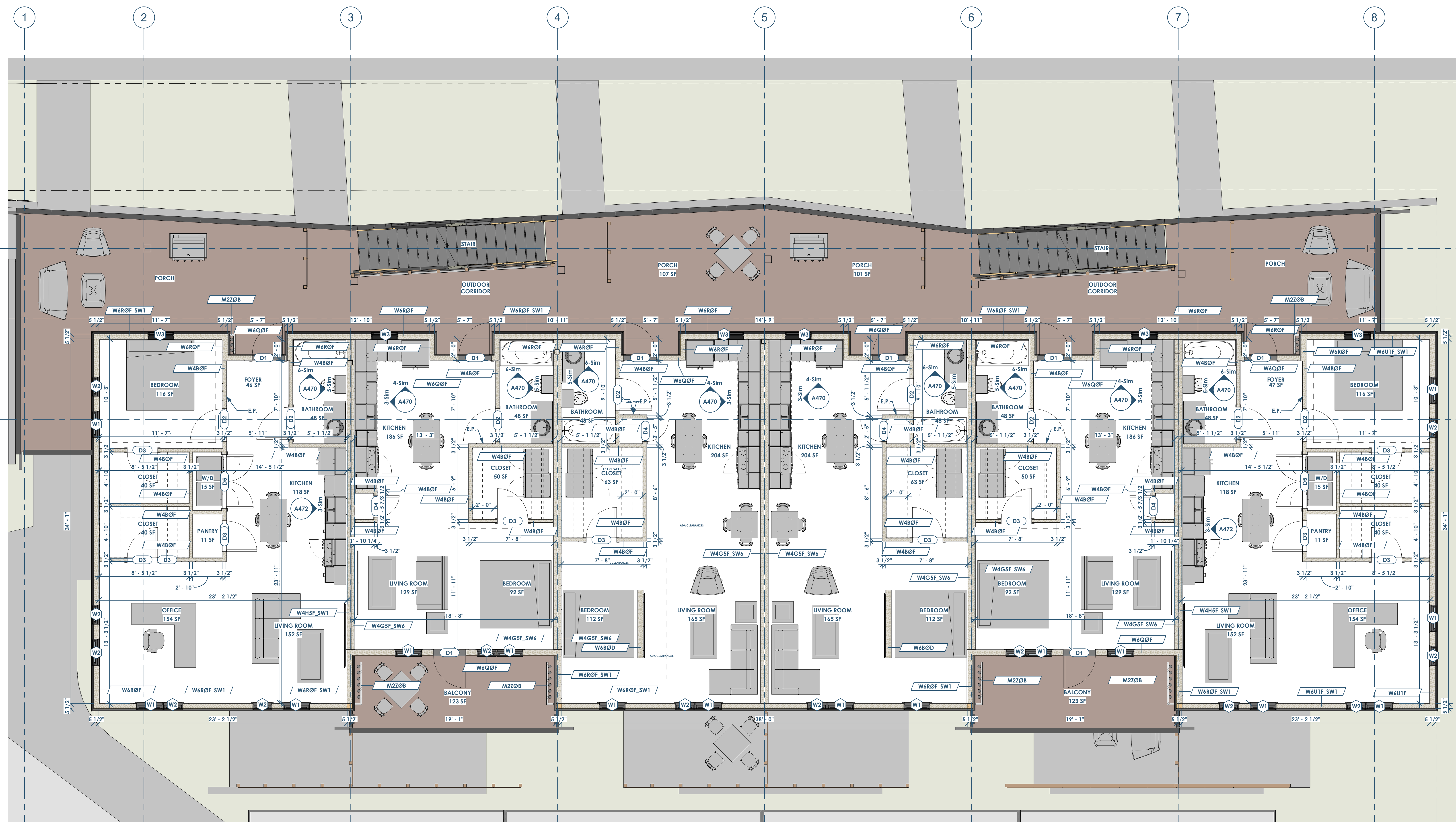

1  
A102 FLOOR PLAN - 2ND FLOOR  
1/4" = 1'-0"

This project, like most OpeningDesign's projects, is open source (Attribution-ShareAlike 4.0 International-CC BY-SA 4.0)-freely available to any party for future use, assuming the terms such as Attribution and ShareAlike are honored.

openingdesign  
Architect: OpeningDesign  
17 S Fairchild | FL 7  
Madison, WI 53703  
ryan@openingdesign.com | 773.425.6456

Date	Description
05.19.2022	Progress Set

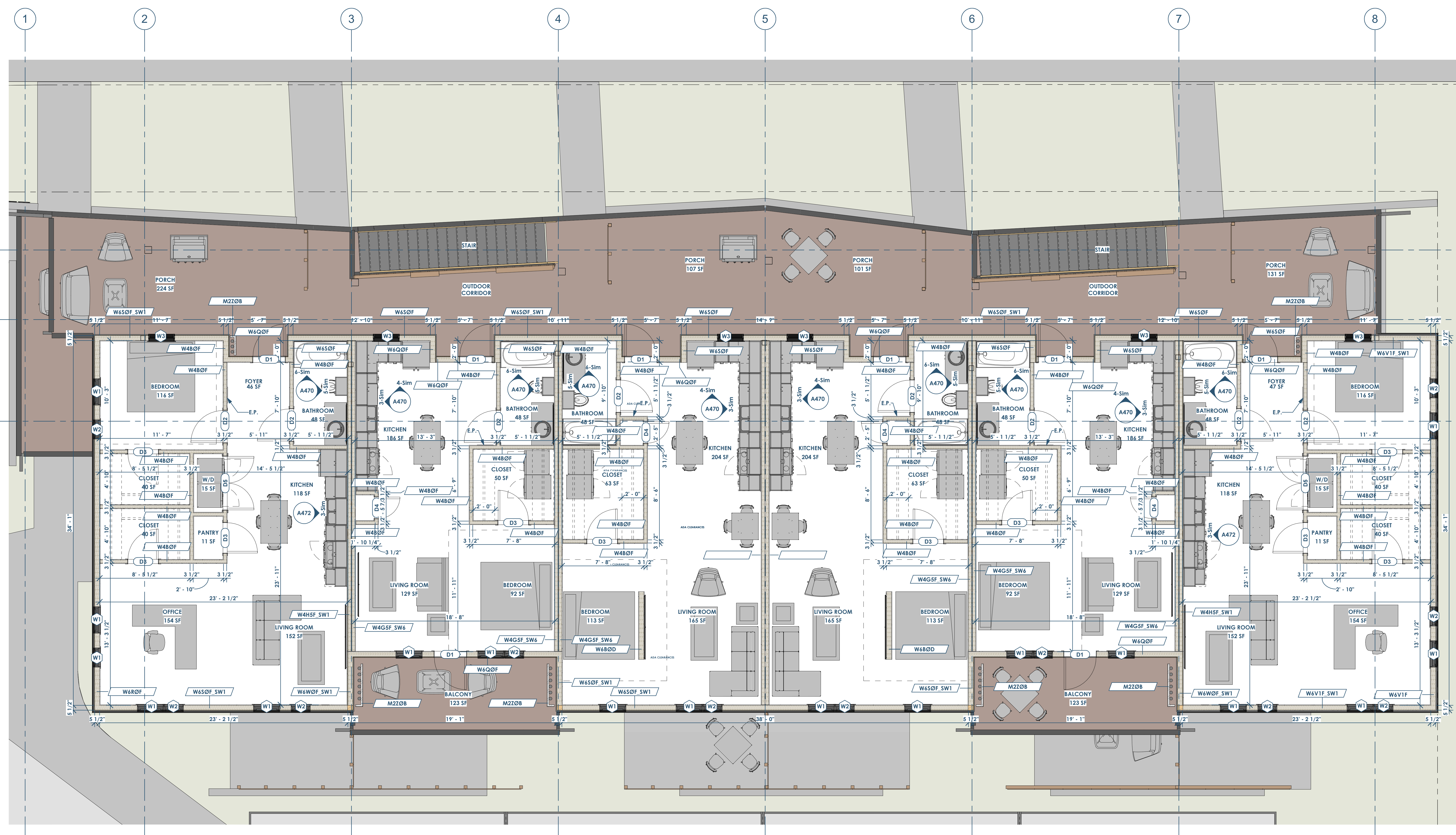

1 A103 FLOOR PLAN - 3RD FLOOR  
1/4" = 1'-0"

This project, like most OpeningDesign's projects, is open source (Attribution-ShareAlike 4.0 International-CC BY-SA 4.0)-freely available to any party for future use, assuming the terms such as Attribution and ShareAlike are honored.

Date	Description
05.19.2022	Progress Set











6C A201 BUILDING ELEVATION - SOUTH  
3/16" = 1'-0"

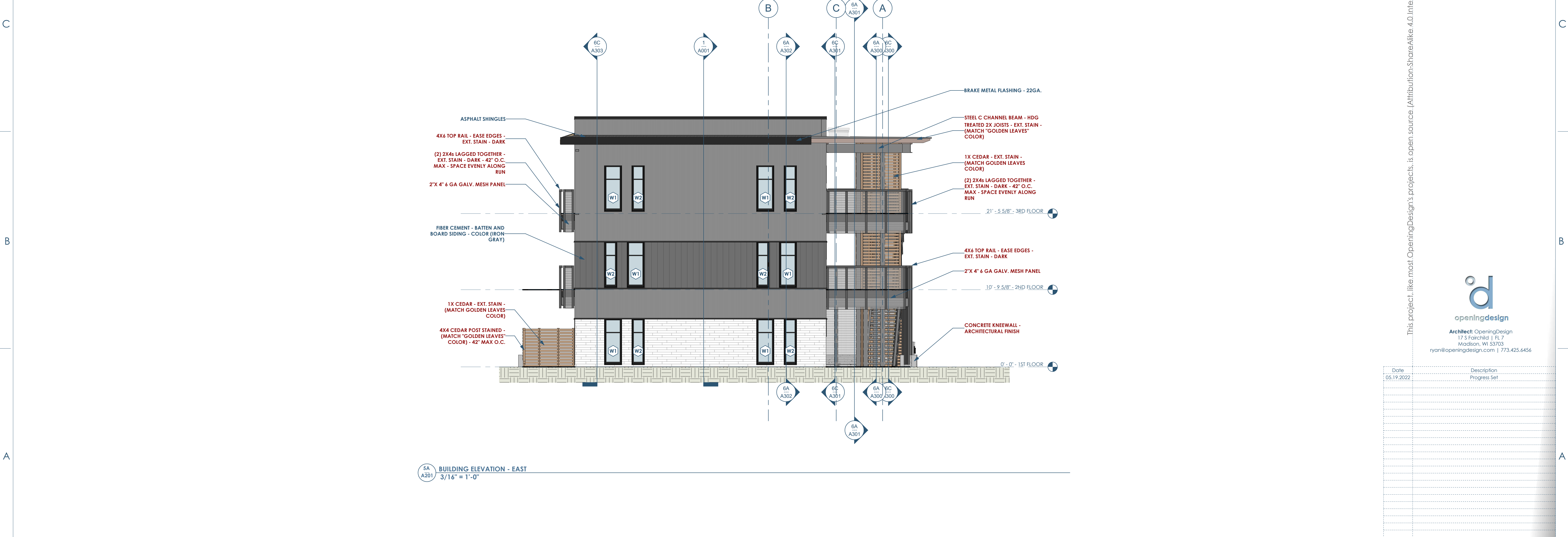

6A A201 BUILDING ELEVATION - EAST  
3/16" = 1'-0"

**RENOVATION**  
Wranglers  
Owner: Renovation Wranglers  
102 E 26th St  
Bryan, TX 77803  
Kateneason@wranglers.com | 979.450.9969

**LKB**  
ARCHITECTURE  
Architect of Record: LKB Architecture  
2929 Allen Pkwy Suite 200  
Houston, TX 77019  
isa@lkbarchitecture.com | 713.425.3076

**DUDDLEY**  
Structural: Dudley  
6102 Imperial Loop Drive  
College Station, TX 77845  
(979) 777-0720

**amc**  
ENGINEERS  
MEP: AMC Engineers  
508 E Jackson St # 552  
Burnet, TX 78611  
info@amcengineers.com

This project, like most OpeningDesign's projects, is open source (Attribution-ShareAlike 4.0 International-CC BY-SA 4.0)-freely available to any party for future use, assuming the terms such as Attribution and ShareAlike are honored.

**openingdesign**  
Architect: OpeningDesign  
17 S Fairchild | FL 7  
Madison, WI 53703  
ryan@openingdesign.com | 773.425.6456

Date	Description
05.19.2022	Progress Set



**RENOVATION**  
Wranglers  
Engineers

Owner: Renovation Wranglers  
102 E 26th St  
Bryan, TX 77803  
Kateneason@time.com | 979.450.9969

**LKB**  
ARCHITECTURE

Architect of Record: LKB Architecture  
2929 Allen Pkwy Suite 200  
Houston, TX 77019  
isa@lkbarchitecture.com | 713.425.3076

**DUDLEY**

Structural: Dudley  
6102 Imperial Loop Drive  
College Station, TX 77845  
(979) 777-0720

**amc**  
ENGINEERS

MEP: AMC Engineers  
508 E Jackson St # 552  
Burnet, TX 78611  
info@amcengineers.com

This project, like most OpeningDesign's projects, is open source (Attribution-ShareAlike 4.0 International-CC BY-SA 4.0)-freely available to any party for future use, assuming the terms such as Attribution and ShareAlike are honored.



4C A301 BUILDING SECTION - THRU BALCONY - LOOKING SOUTH  
3/16" = 1'-0"

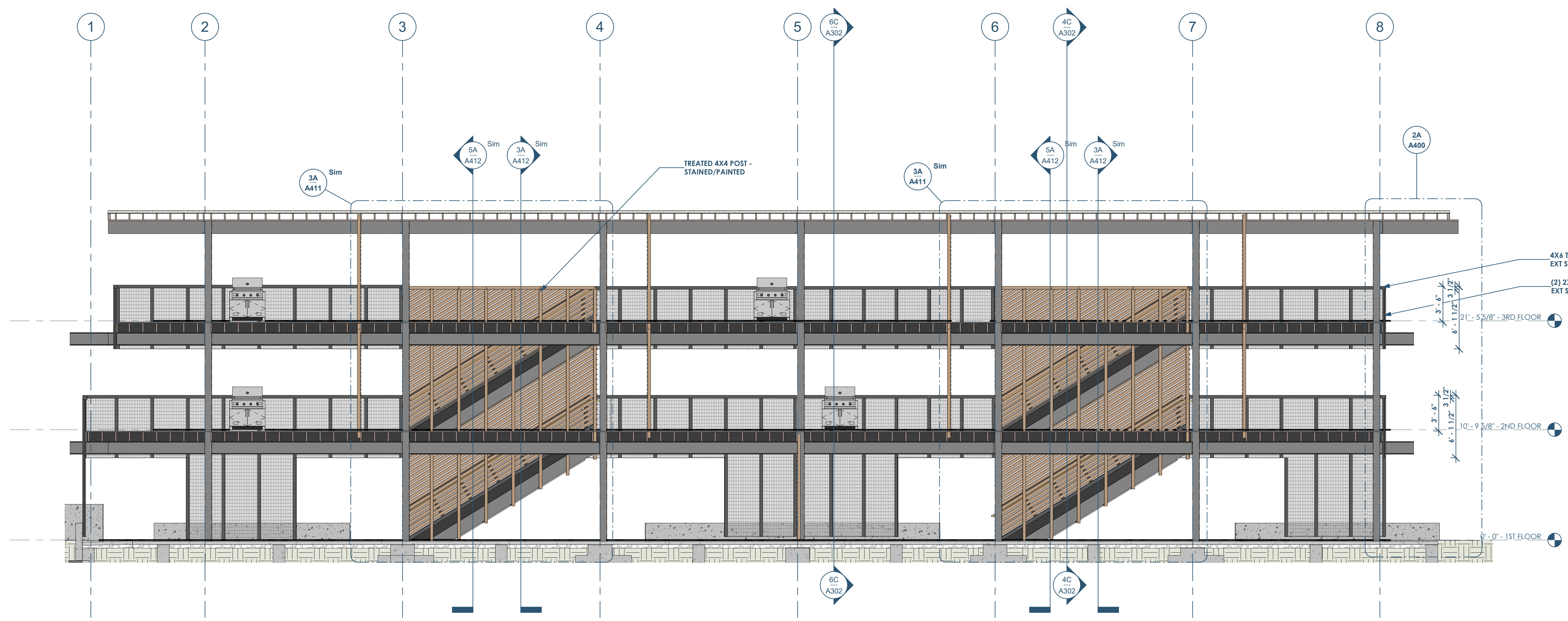

6A A301 BUILDING SECTION - THRU BALCONY - LOOKING NORTH  
3/16" = 1'-0"

**openingdesign**

Architect: OpeningDesign  
17 S Fairchild | FL 7  
Madison, WI 53703  
ryan@openingdesign.com | 773.425.6456

Date	Description
05.19.2022	Progress Set

**RENOVATION**  
Wranglers  
Engineers

Owner: Renovation Wranglers  
102 E 26th St  
Bryan, TX 77803  
Kateneason@time.com | 979.450.9969

**ARCHITECTURE**  
Architect of Record: LKB Architecture  
2929 Allen Pkwy Suite 200  
Houston, TX 77019  
isa@lkbarchitecture.com | 713.425.3076

**STRUCTURAL**  
Structural: Dudley  
4102 Imperial Loop Drive  
College Station, TX 77845  
(979) 777-0720

**MEP**  
MEP: AMC Engineers  
508 E Jackson St # 552  
Burnet, TX 78611  
info@amcengineers.com

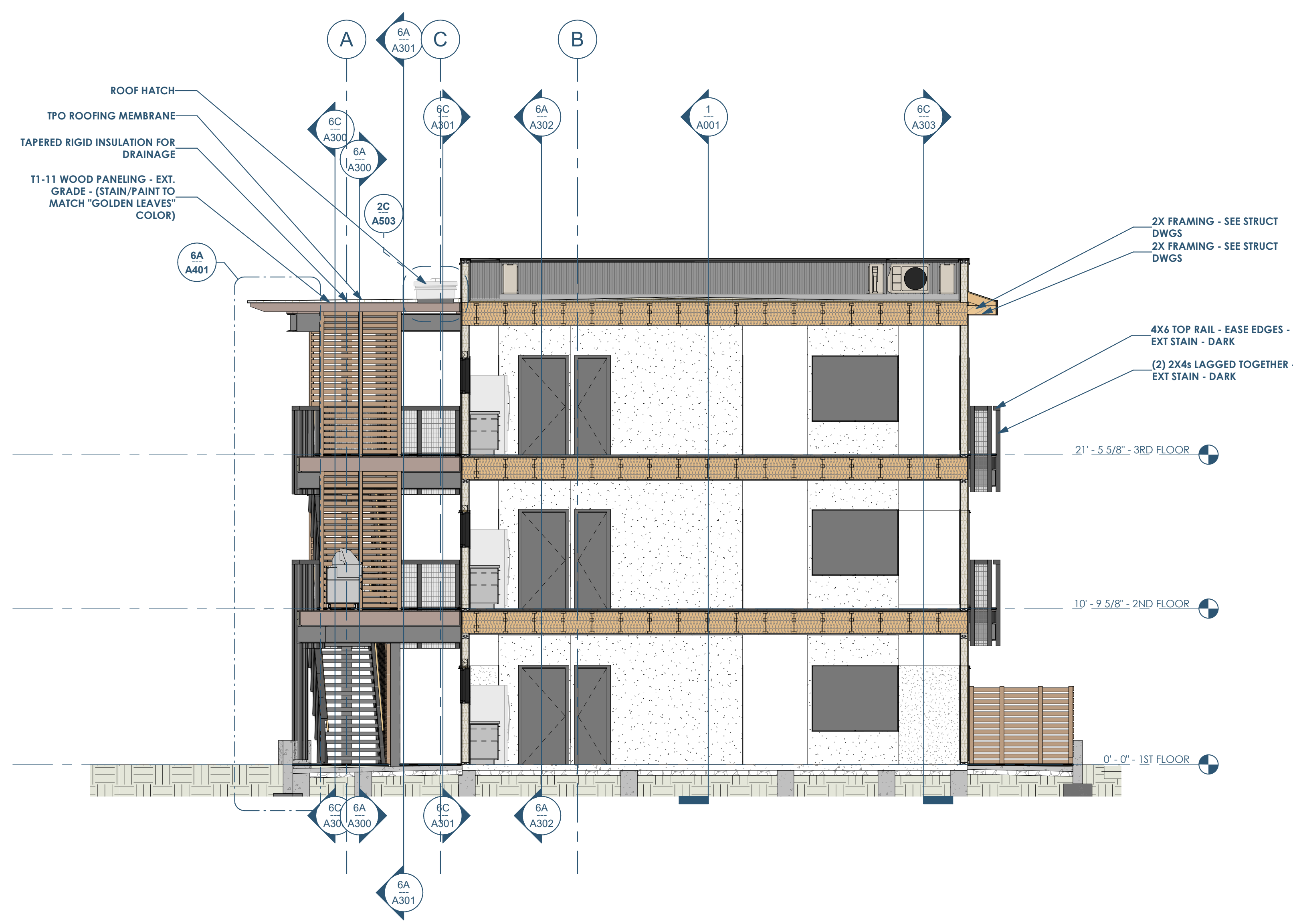

4C A302 BUILDING SECTION - THRU LARGE STUDIO - LOOKING EAST  
3/16" = 1'-0"

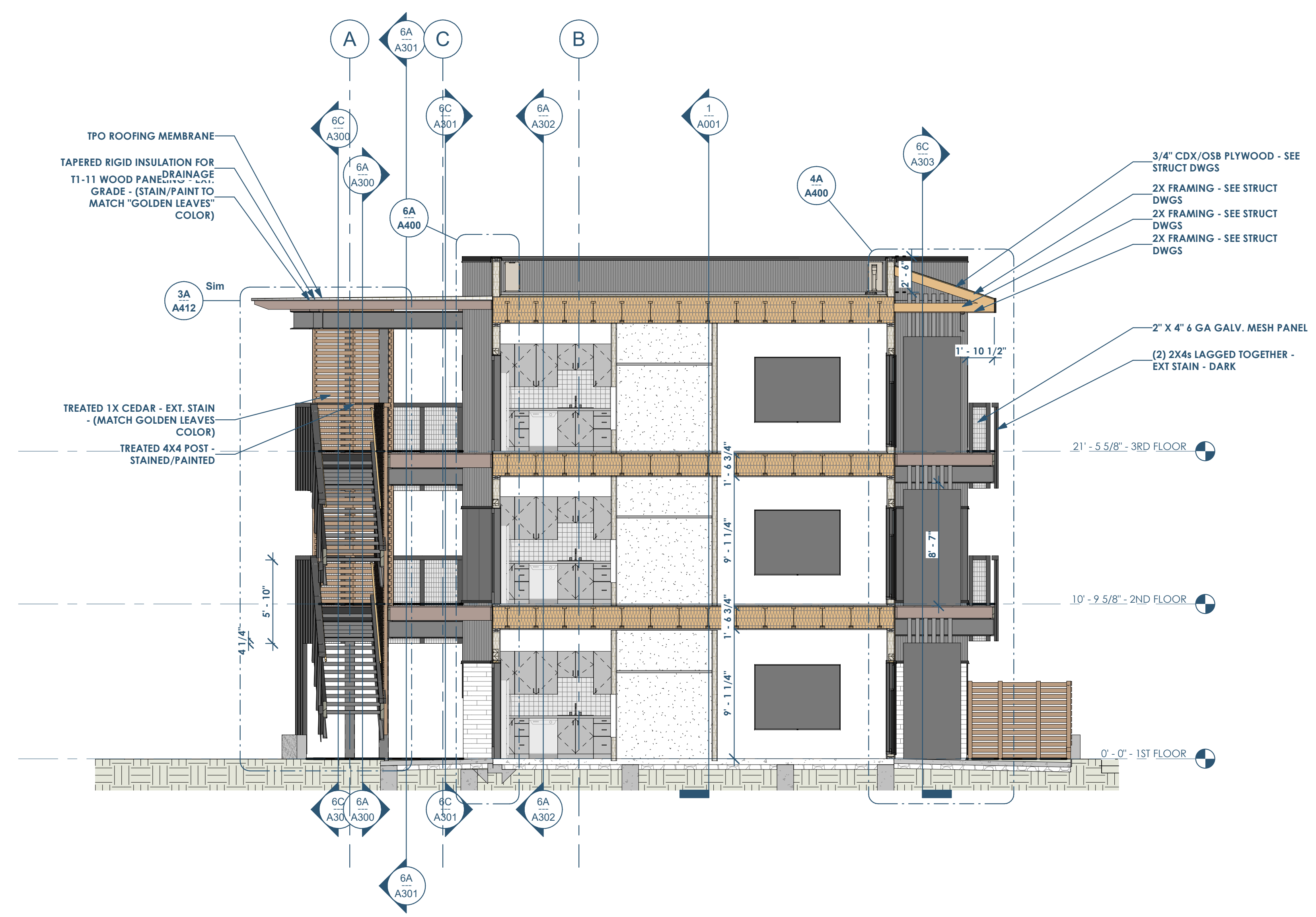

4C A302 BUILDING SECTION - THRU SMALL STUDIO - LOOKING EAST  
3/16" = 1'-0"



4A A302 BUILDING SECTION - EAST/WEST - LOOKING NORTH  
3/16" = 1'-0"

This project, like most OpeningDesign's projects, is open source (Attribution-ShareAlike 4.0 International-CC BY-SA 4.0)-freely available to any party for future use, assuming the terms such as Attribution and ShareAlike are honored.

**openingdesign**

Architect: OpeningDesign  
17 S Fairchild | FL 7  
Madison, WI 53703  
ryan@openingdesign.com | 773.425.6456

Date	Description
05.19.2022	Progress Set



This project, like most OpeningDesign's projects, is open source. (Attribution-ShareAlike 4.0 International-CC BY-SA 4.0)-freely available to any party for future use, assuming the terms such as Attribution and ShareAlike are honored.

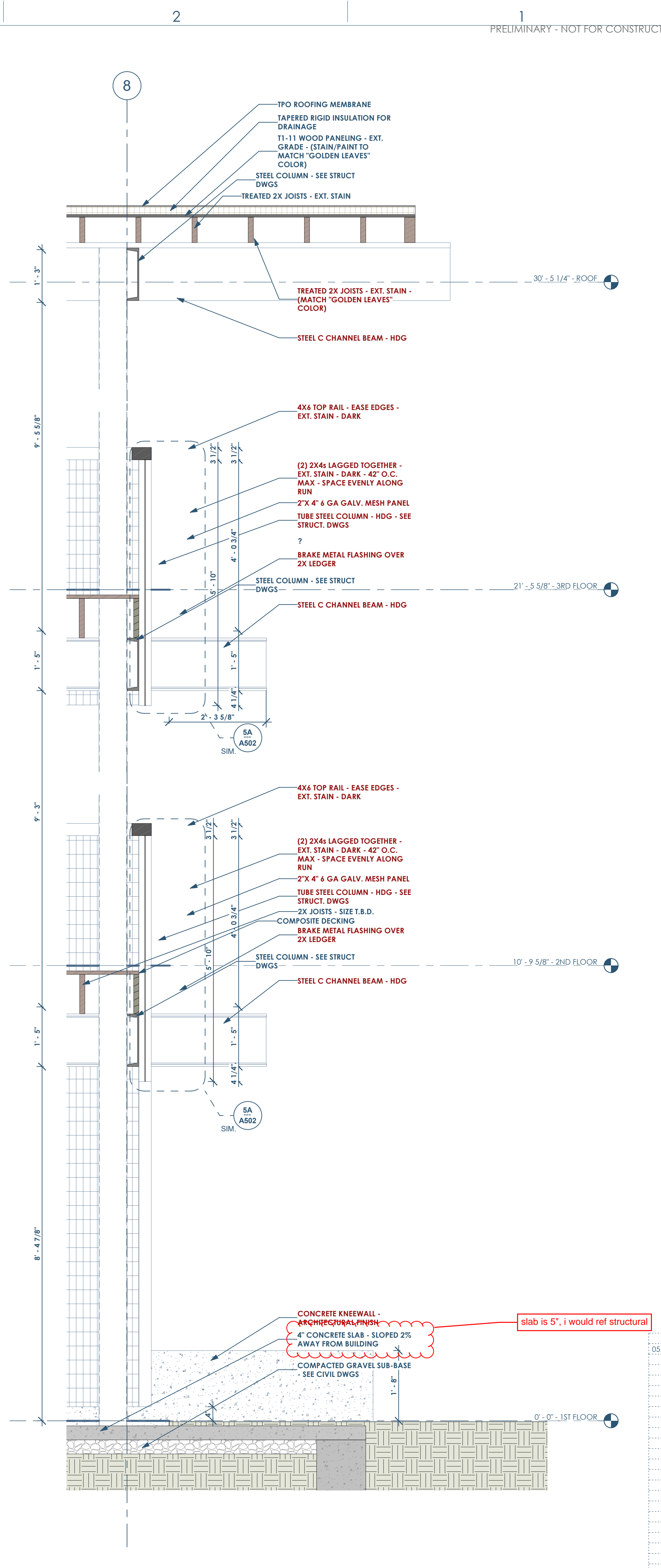
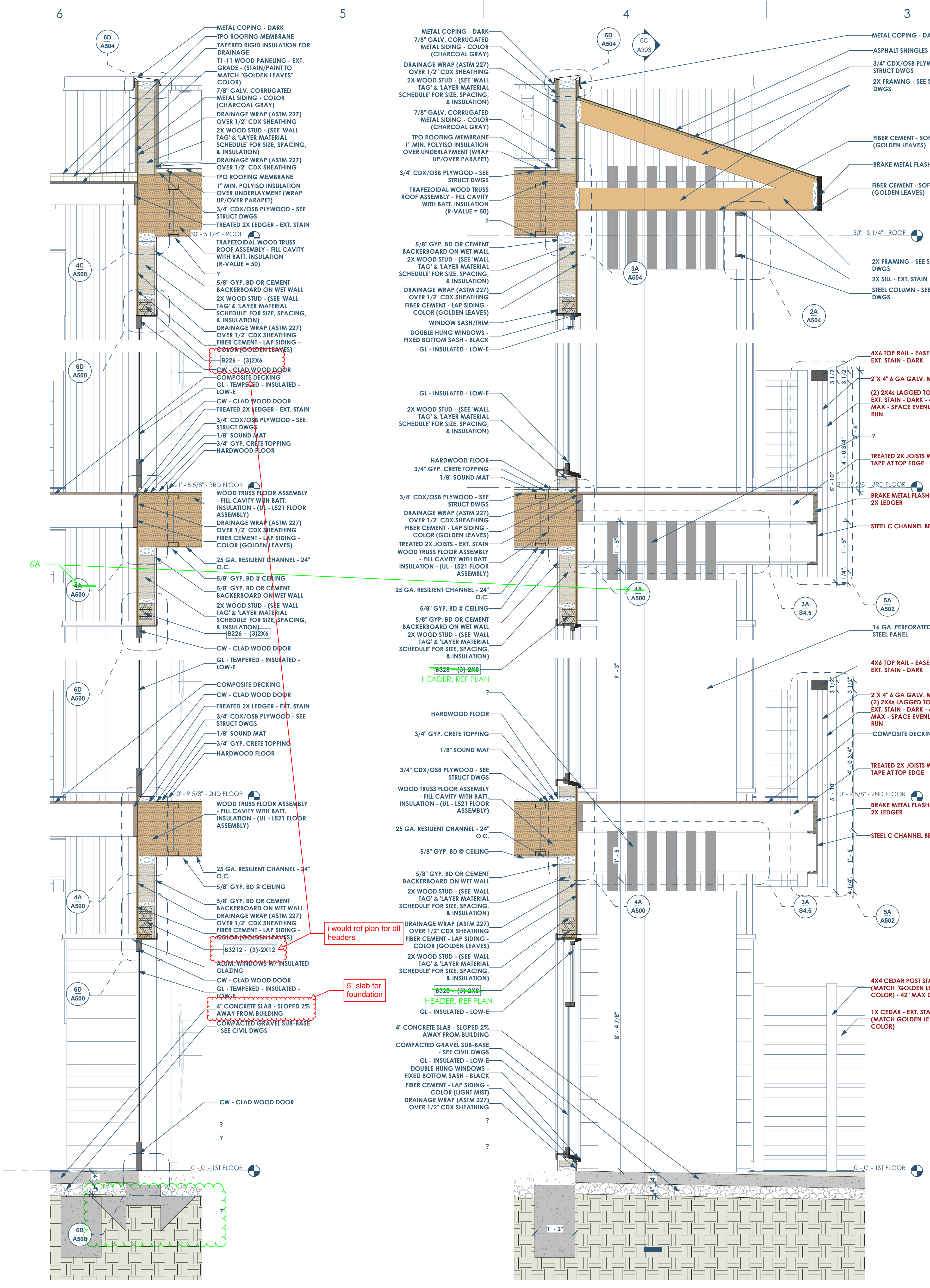

**RENOVATION**  
Architects

Owner: Revolutions Wranglers  
102 E 26th St  
Bryan, TX 77803  
Katherine@renovations.com | 979.450.9969

**ARCHITECTURE**  
Architect of Record: LKB Architecture  
2929 Allen Pkwy Suite 200  
Houston, TX 77019  
isa@lkbarchitecture.com | 713.425.3076

**DUDDLEY**  
Structural: Dudley  
6102 Imperial Loop Drive  
College Station, TX 77845  
(979) 777-0720

**amc**  
ENGINEERS  
MEP: AMC Engineers  
508 E Jackson St # 552  
Burnet, TX 78611  
info@amcengineers.com

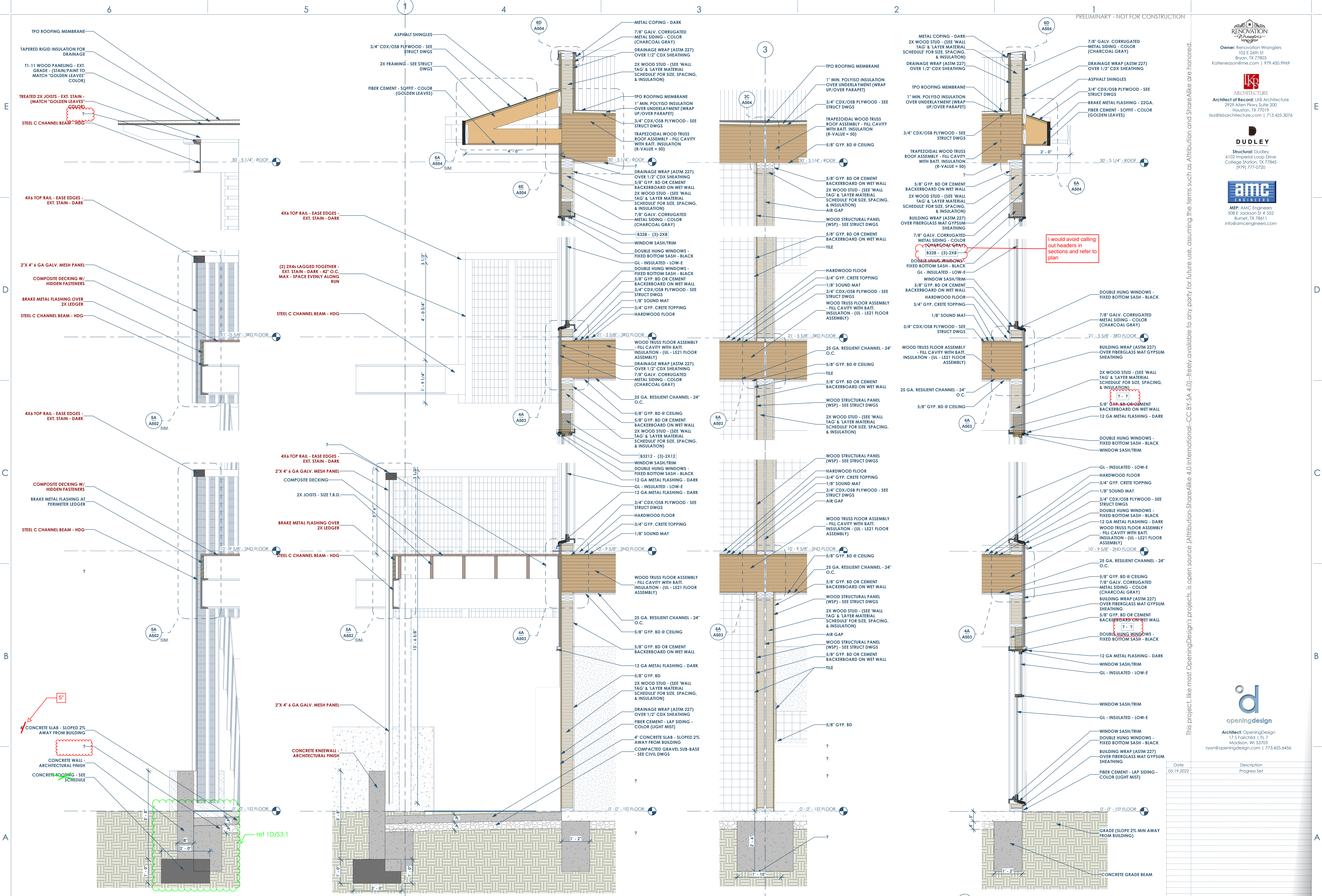

This project, like most OpeningDesign's projects, is open source. (Attribution-ShareAlike.4.0 International-CC BY-SA.4.0)-freely available to any party for future use, assuming the terms such as Attribution and ShareAlike are honored.

**openingdesign**

Architect: OpeningDesign  
17 S Fairchild | FL 7  
Madison, WI 53703  
ryan@openingdesign.com | 773.425.6456

Date	Description
05.19.2022	Progress Set

6A A401 BUILDING SECTION - THRU LARGE STUDIO - LOOKING EAST - DECO RAILING  
3/4" = 1'-0"

5A A401 WALL SECTION - EAST/WEST - BALCONY DECK  
3/4" = 1'-0"

3A A401 WALL SECTION - EAST/WEST2 - @ UNITS PARTITION WALL  
3/4" = 1'-0"

2A A401 BUILDING SECTION - EAST/WEST - LOOKING SOUTH - TRU WINDOWS  
3/4" = 1'-0"

WALL SECTIONS







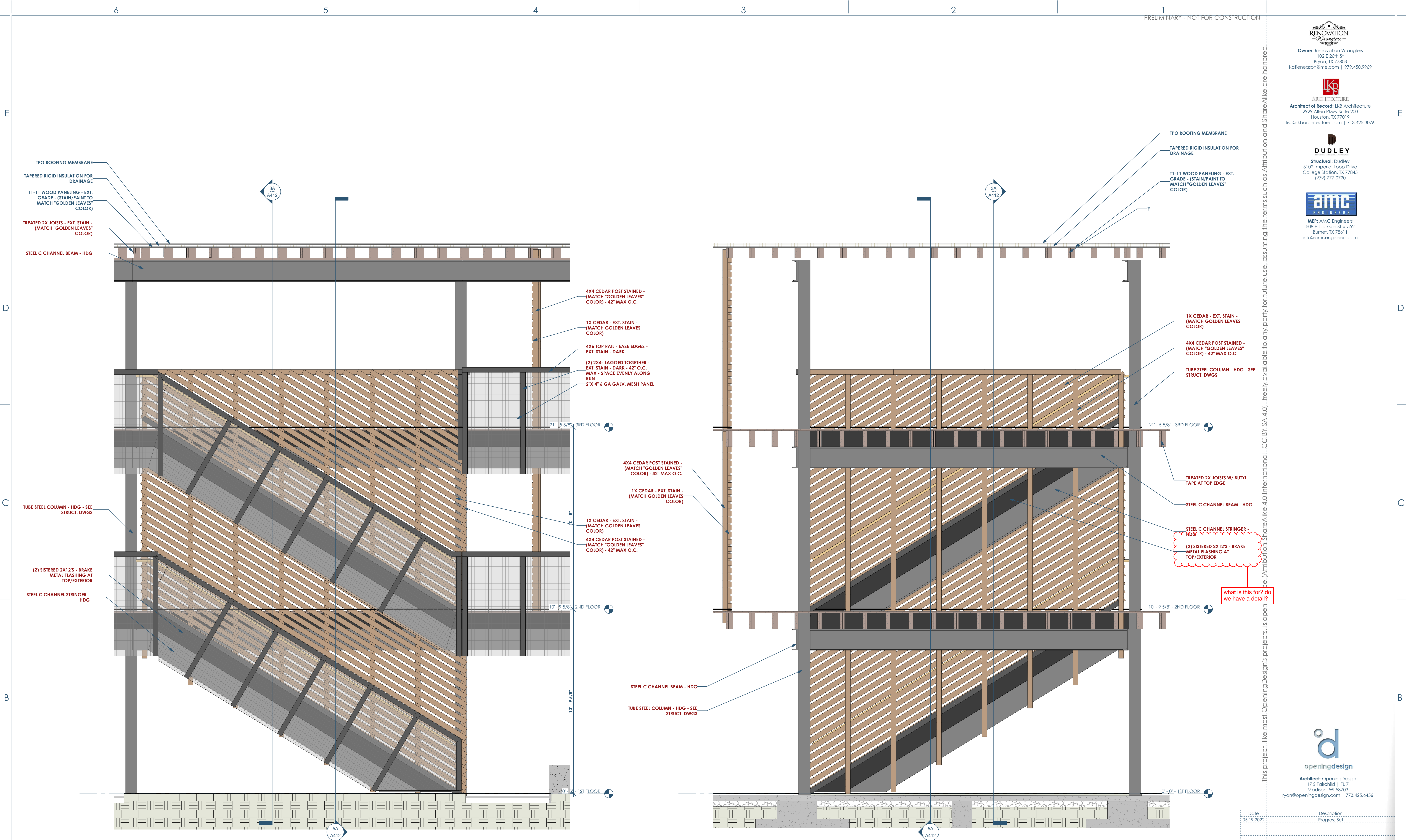

what is this for? do we have a detail?

This project, like most OpeningDesign's projects, is open source. (Attribution: ShareAlike 4.0 International - CC BY-SA 4.0) - freely available to any party for future use, assuming the terms such as Attribution and ShareAlike are honored.

Date	Description
05.19.2022	Progress Set



This project, like most OpeningDesign's projects, is open source (Attribution-ShareAlike 4.0 International-CC BY-SA 4.0)-freely available to any party for future use, assuming the terms such as Attribution and ShareAlike are honored.

Date	Description
05.19.2022	Progress Set

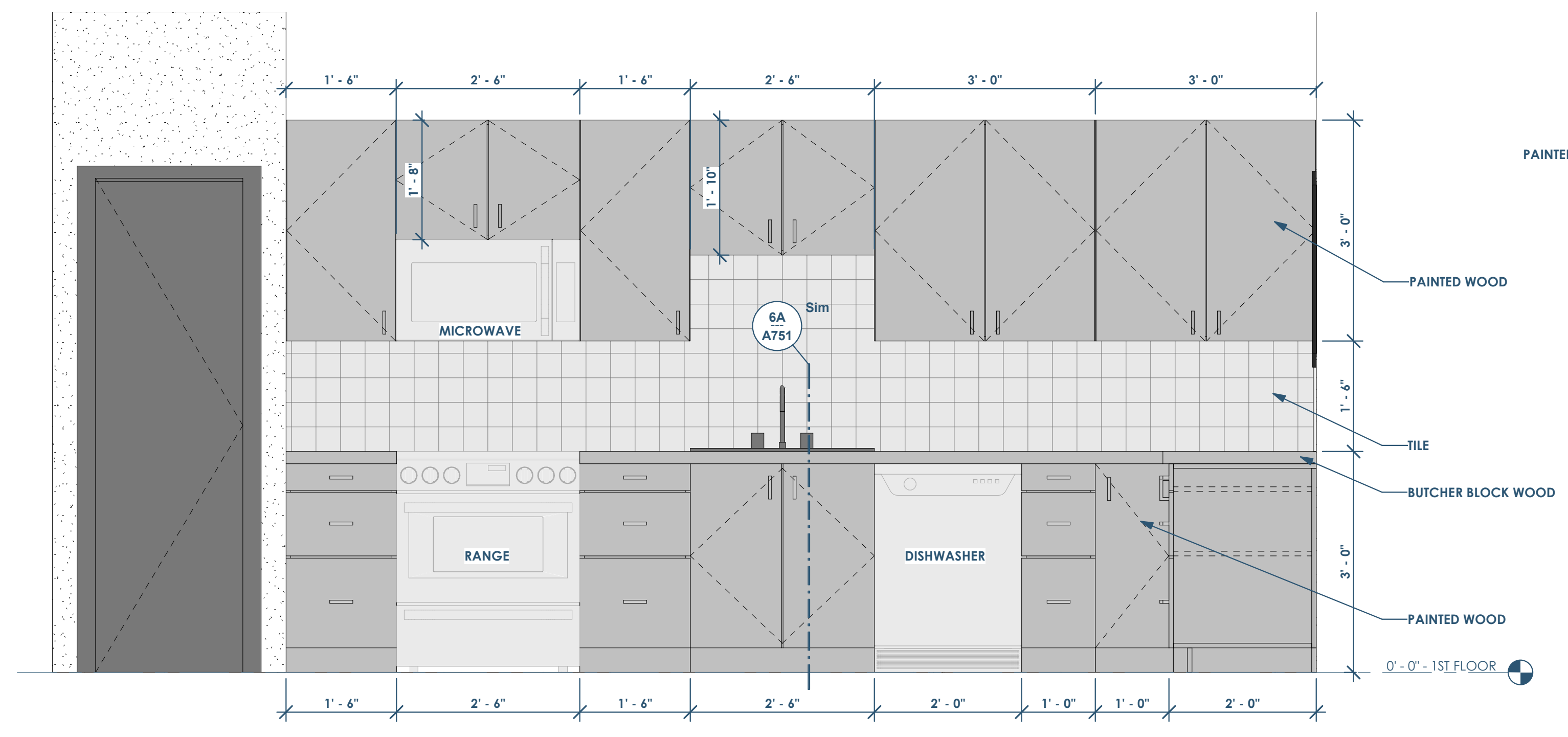

3 ELEVATION - 1 BD - KITCHEN  
3/4" = 1'-0"

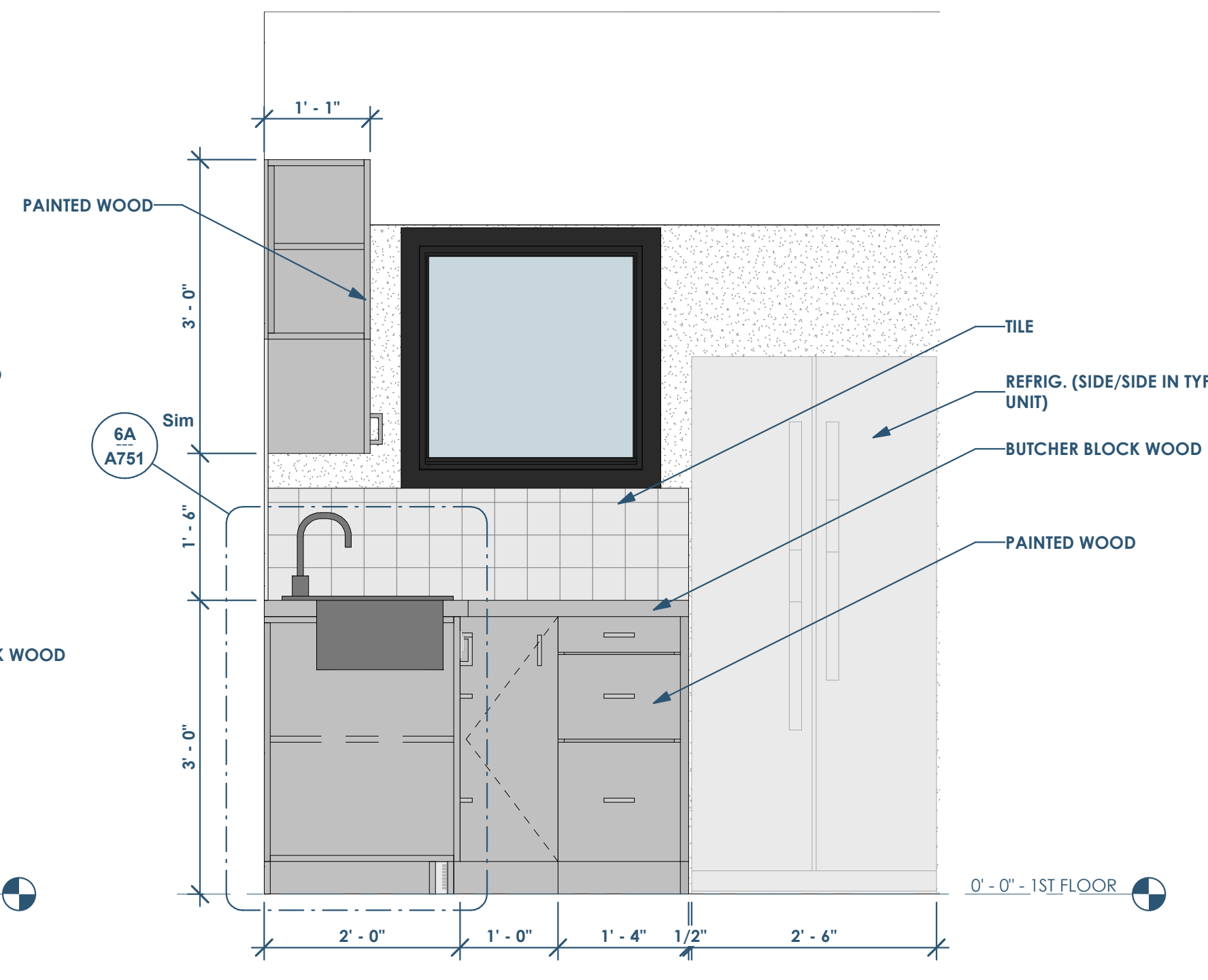

4 ELEVATION - 1 BD - KITCHEN - FRIDGE  
3/4" = 1'-0"

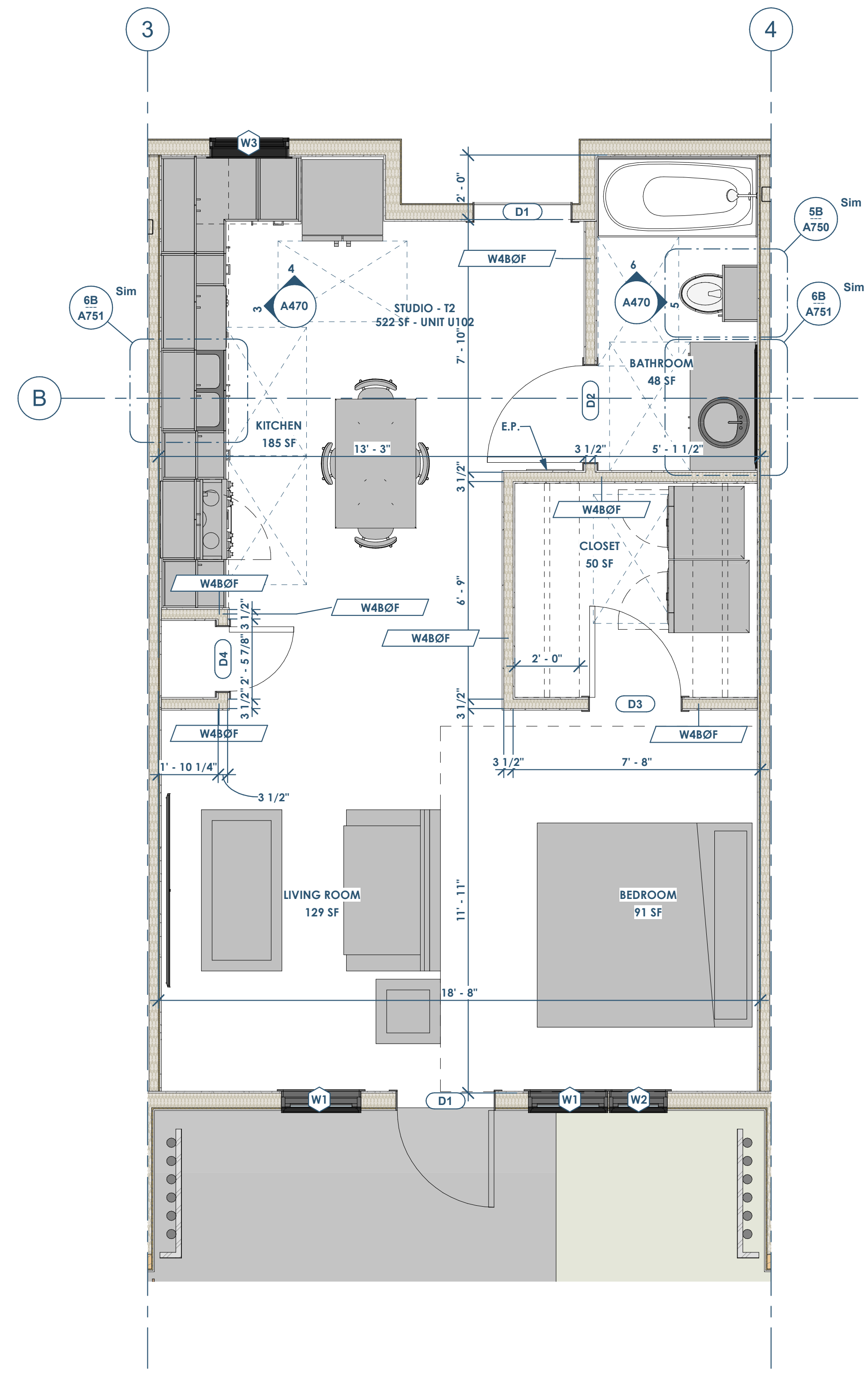

1 UNIT PLAN - 1BD SHORT (TYPE B ADA UNIT - 1ST FLOOR ONLY)  
3/8" = 1'-0"

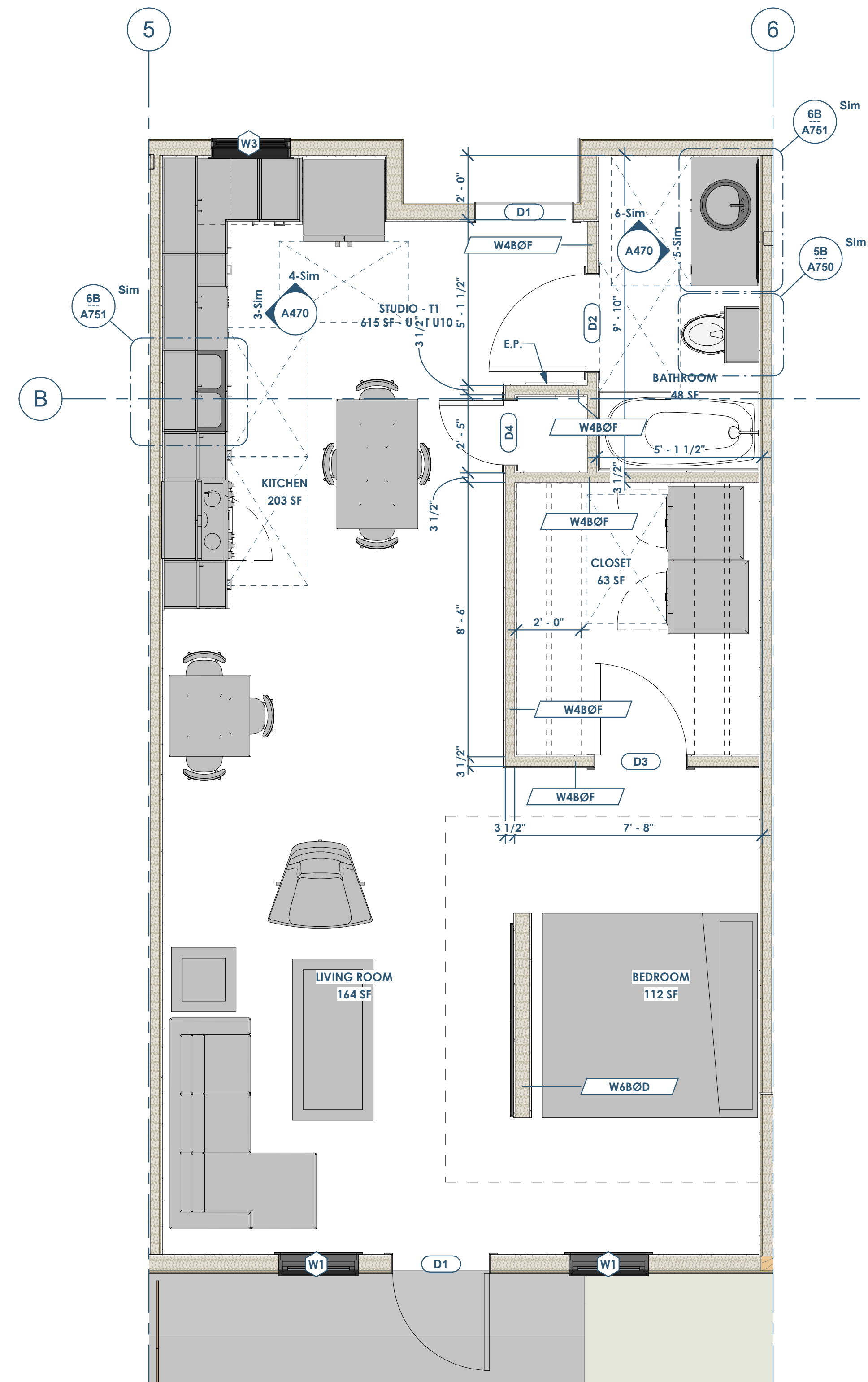

2 UNIT PLAN - 1BD LONG (TYPE B ADA UNIT - 1ST FLOOR ONLY)  
3/8" = 1'-0"

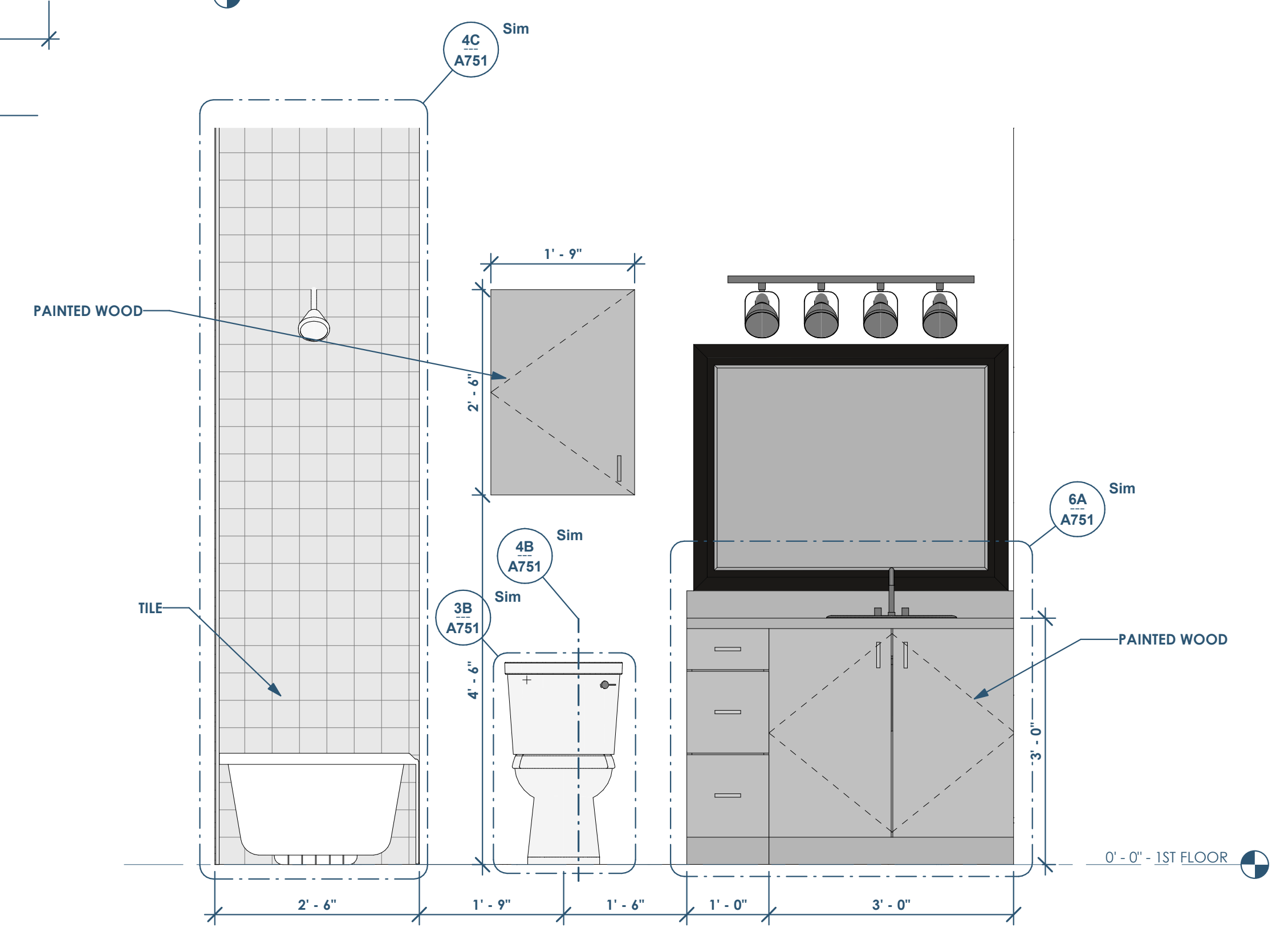

5 ELEVATION - BATH - LAV  
3/4" = 1'-0"

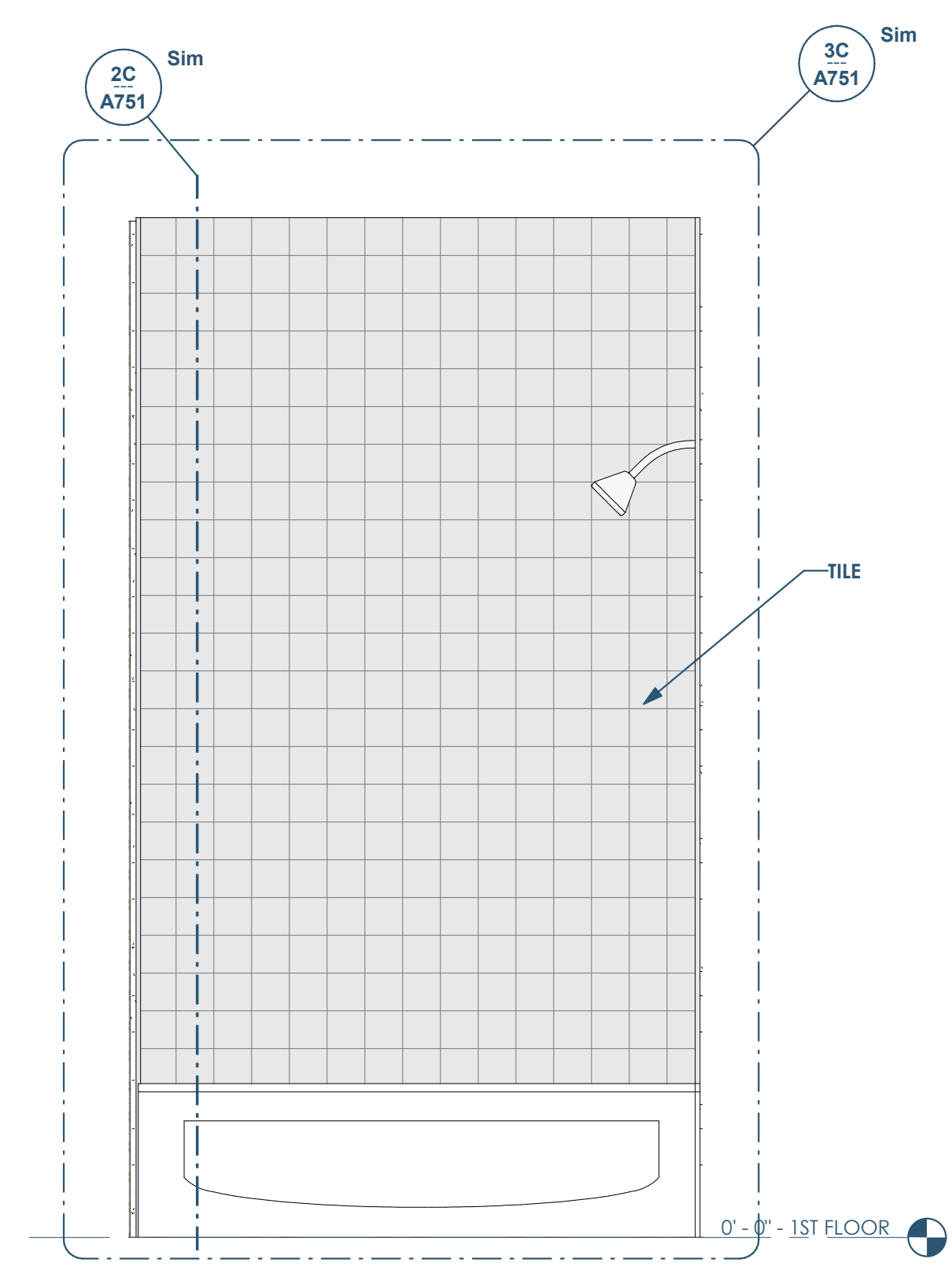

6 ELEVATION - BATH - SHOWER  
3/4" = 1'-0"

**RENOVATION**  
Wranglers  
Engineers

Owner: Renovation Wranglers  
102 E 26th St  
Bryan, TX 77803  
Kateneason@wranglers.com | 979.450.9969

**ARCHITECTURE**  
Architect of Record: LKB Architecture  
2929 Allen Pkwy Suite 200  
Houston, TX 77019  
isa@lkbarchitecture.com | 713.425.3076

**DUDDLEY**  
Structural: Dudley  
6102 Imperial Loop Drive  
College Station, TX 77845  
(979) 777-0720

**amc**  
ENGINEERS  
MEP: AMC Engineers  
508 E Jackson St # 552  
Burnet, TX 78611  
info@amcengineers.com

This project, like most OpeningDesign's projects, is open source (Attribution-ShareAlike 4.0 International-CC BY-SA 4.0)-freely available to any party for future use, assuming the terms such as Attribution and ShareAlike are honored.

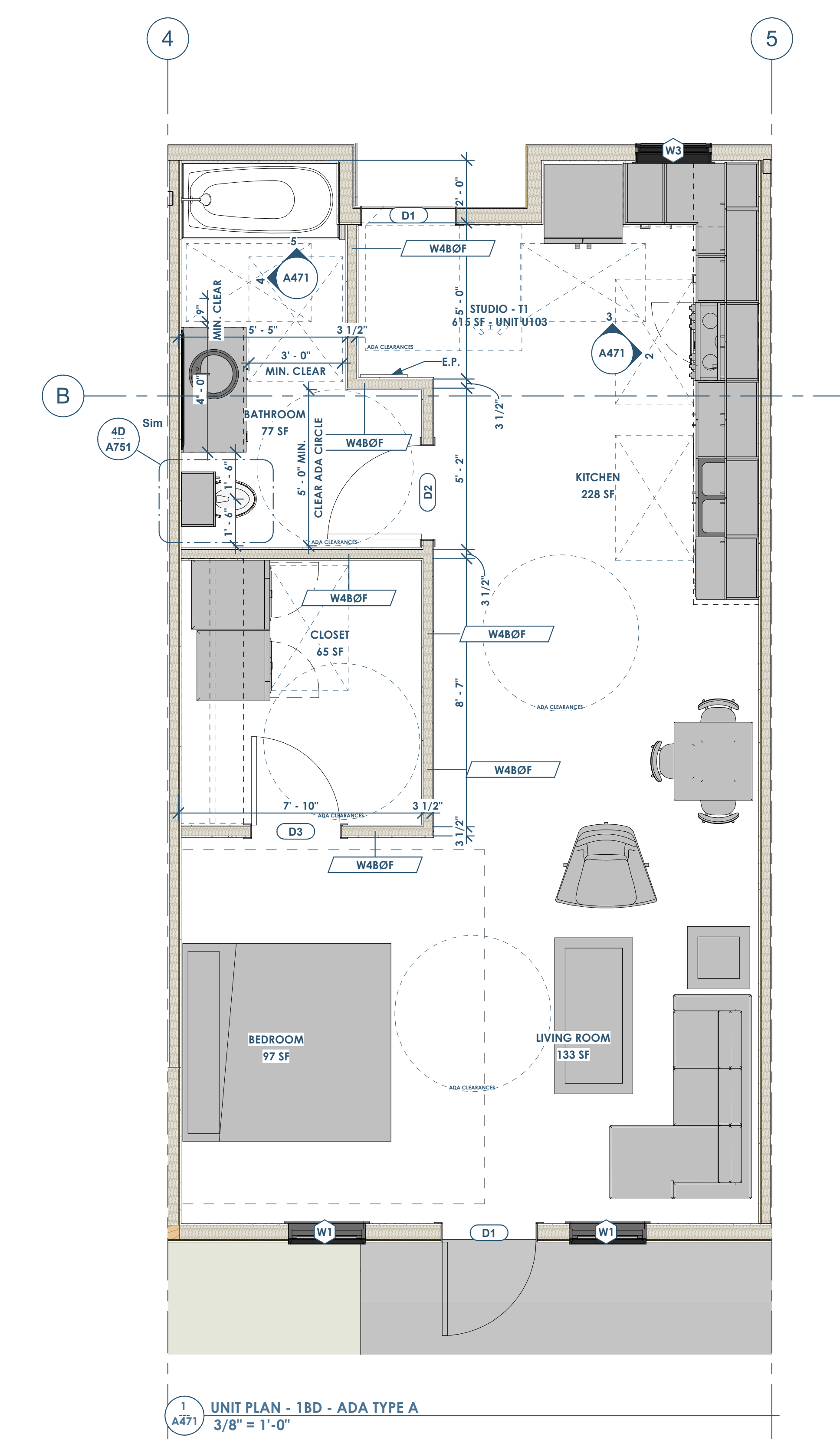
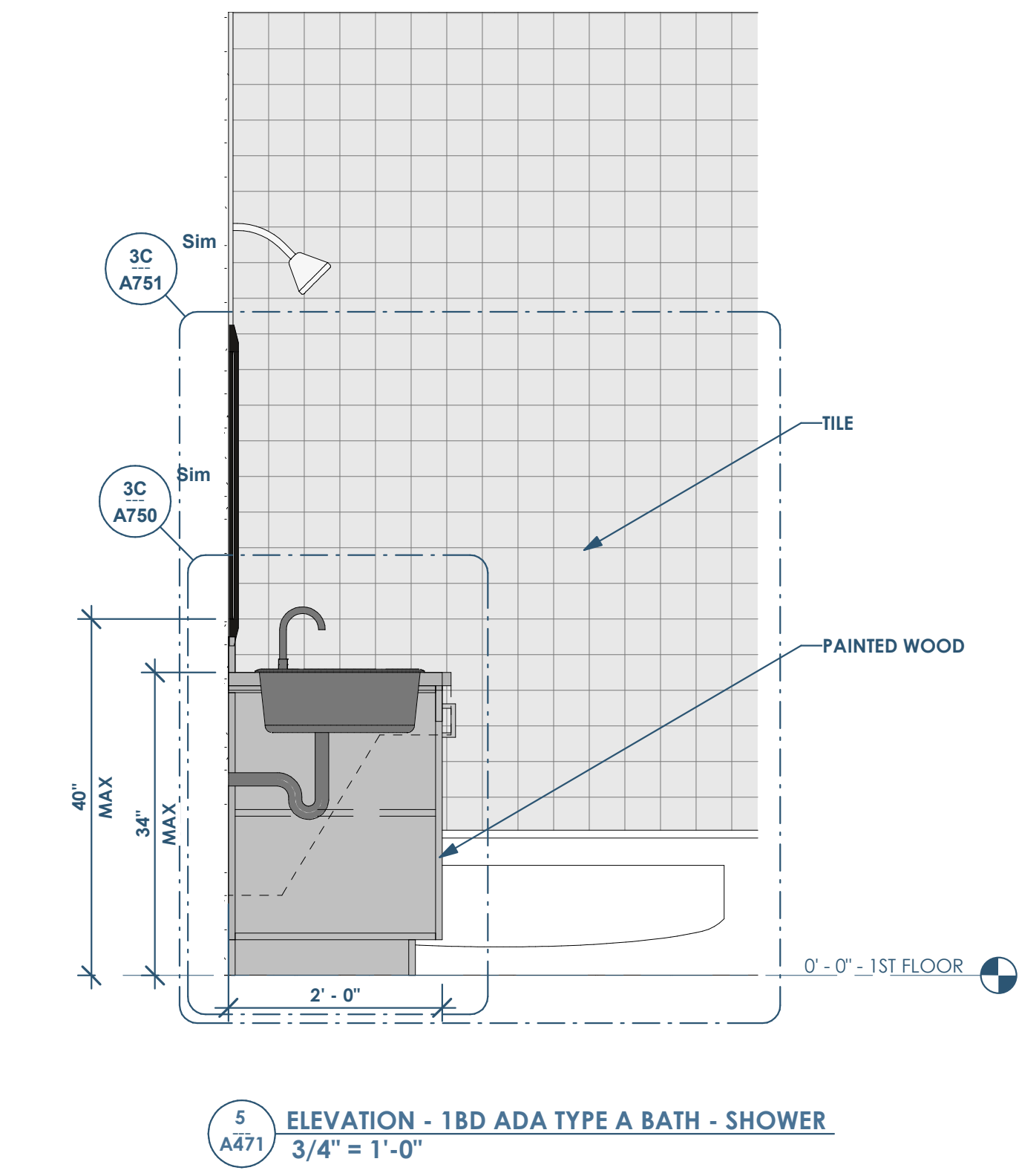
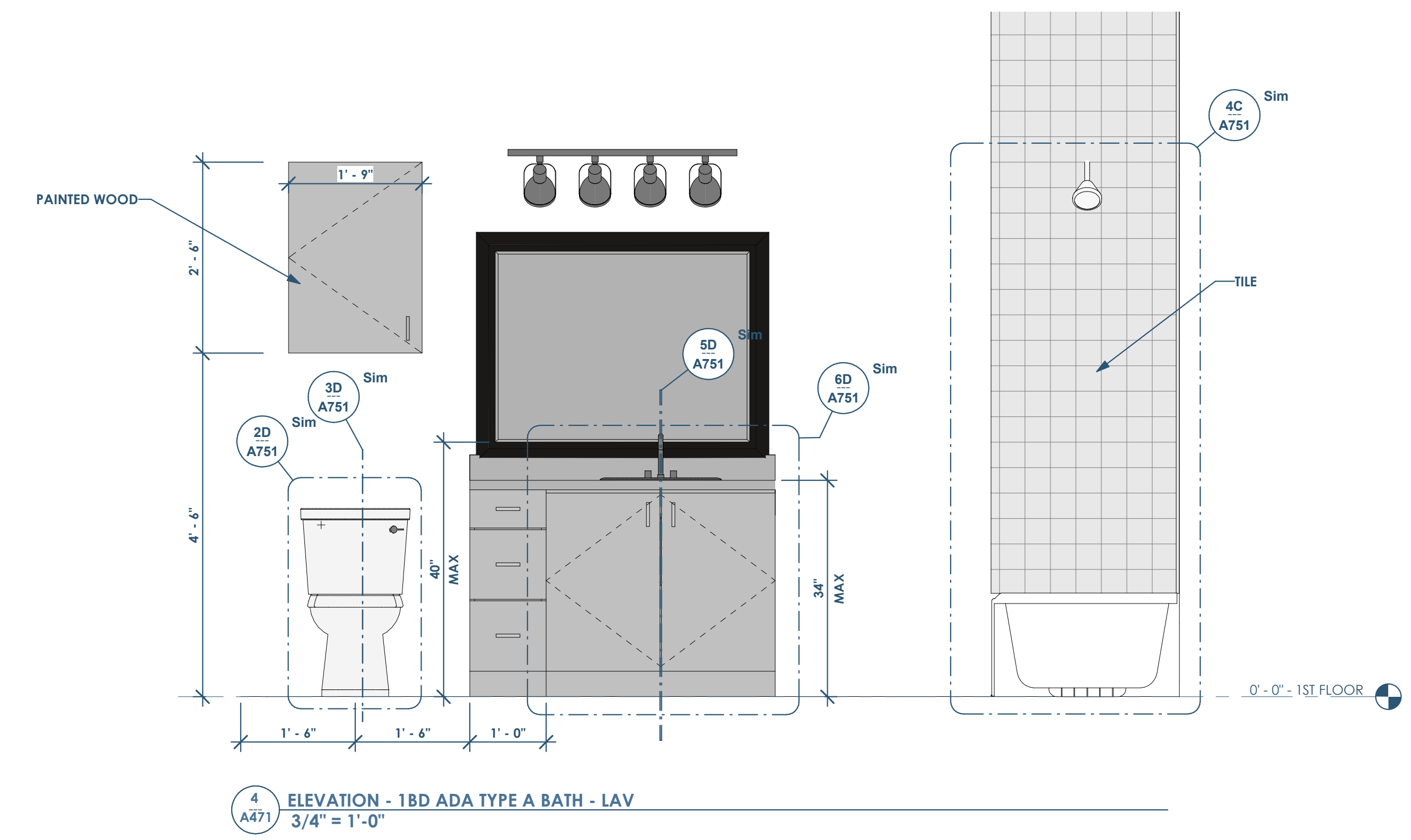
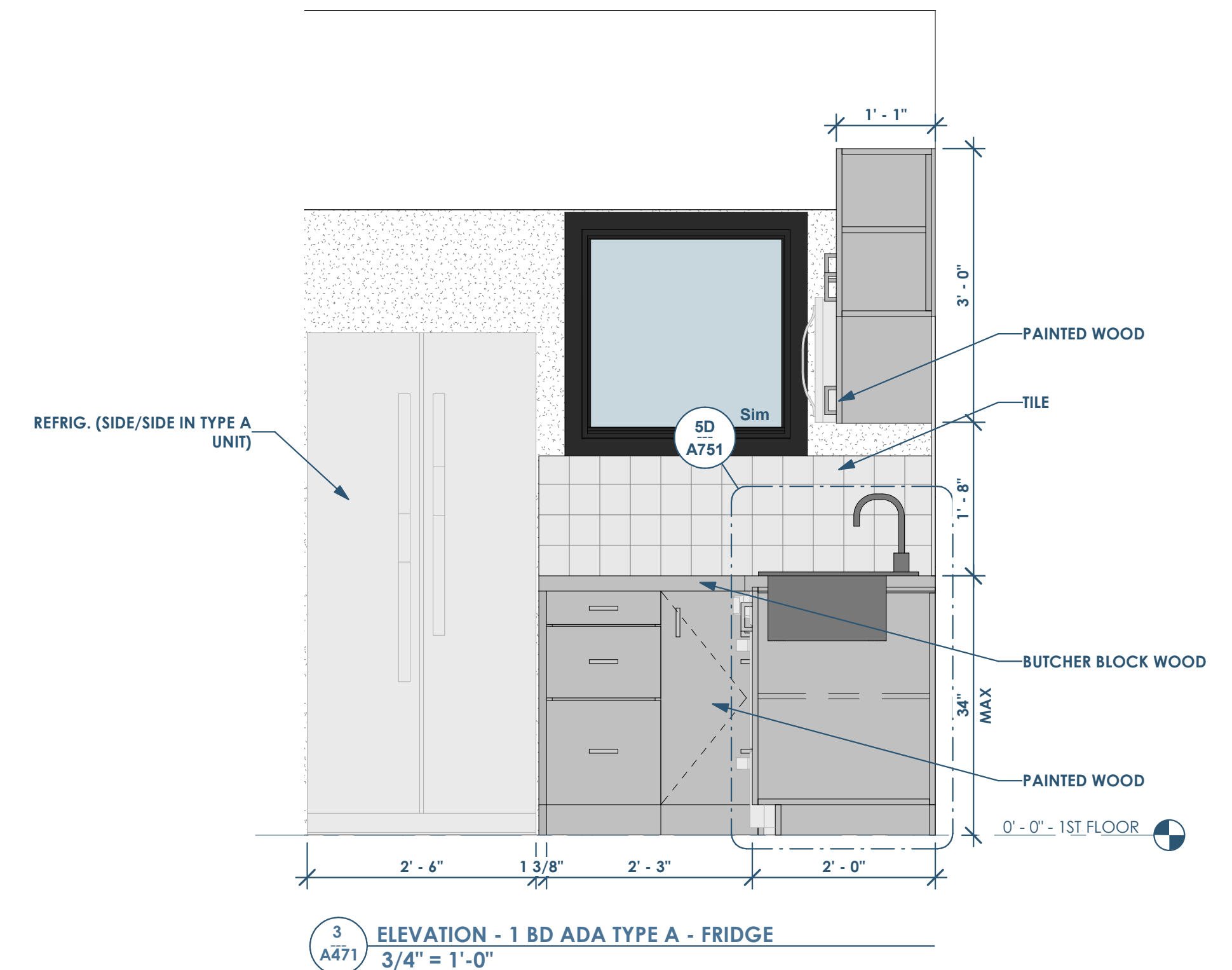
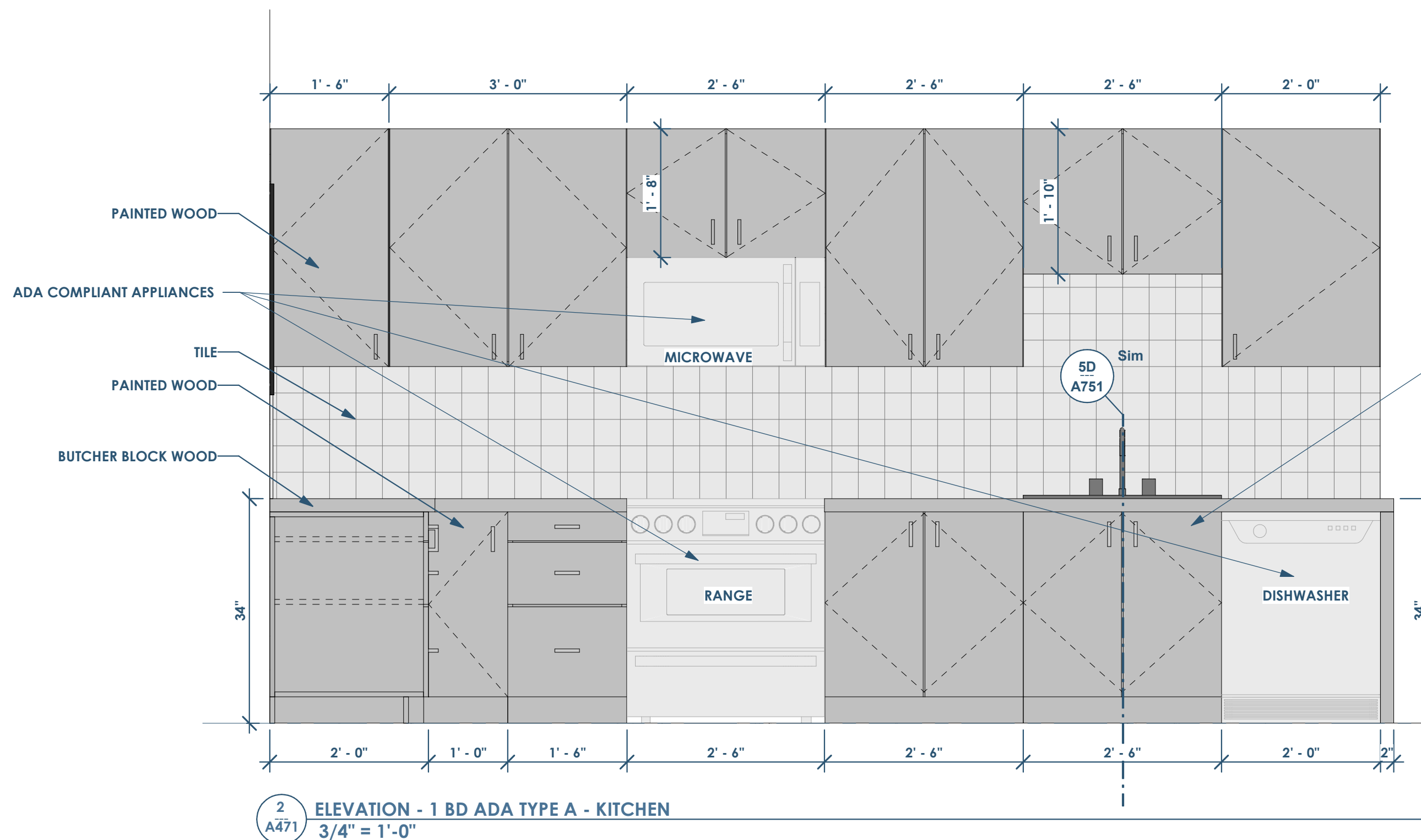

**openingdesign**

Architect: OpeningDesign  
17 S Fairchild | FL 7  
Madison, WI 53703  
ryan@openingdesign.com | 773.425.6456

Date	Description
05.19.2022	Progress Set



This project, like most OpeningDesign's projects, is open source (Attribution-ShareAlike 4.0 International-CC BY-SA 4.0)-freely available to any party for future use, assuming the terms such as Attribution and ShareAlike are honored.

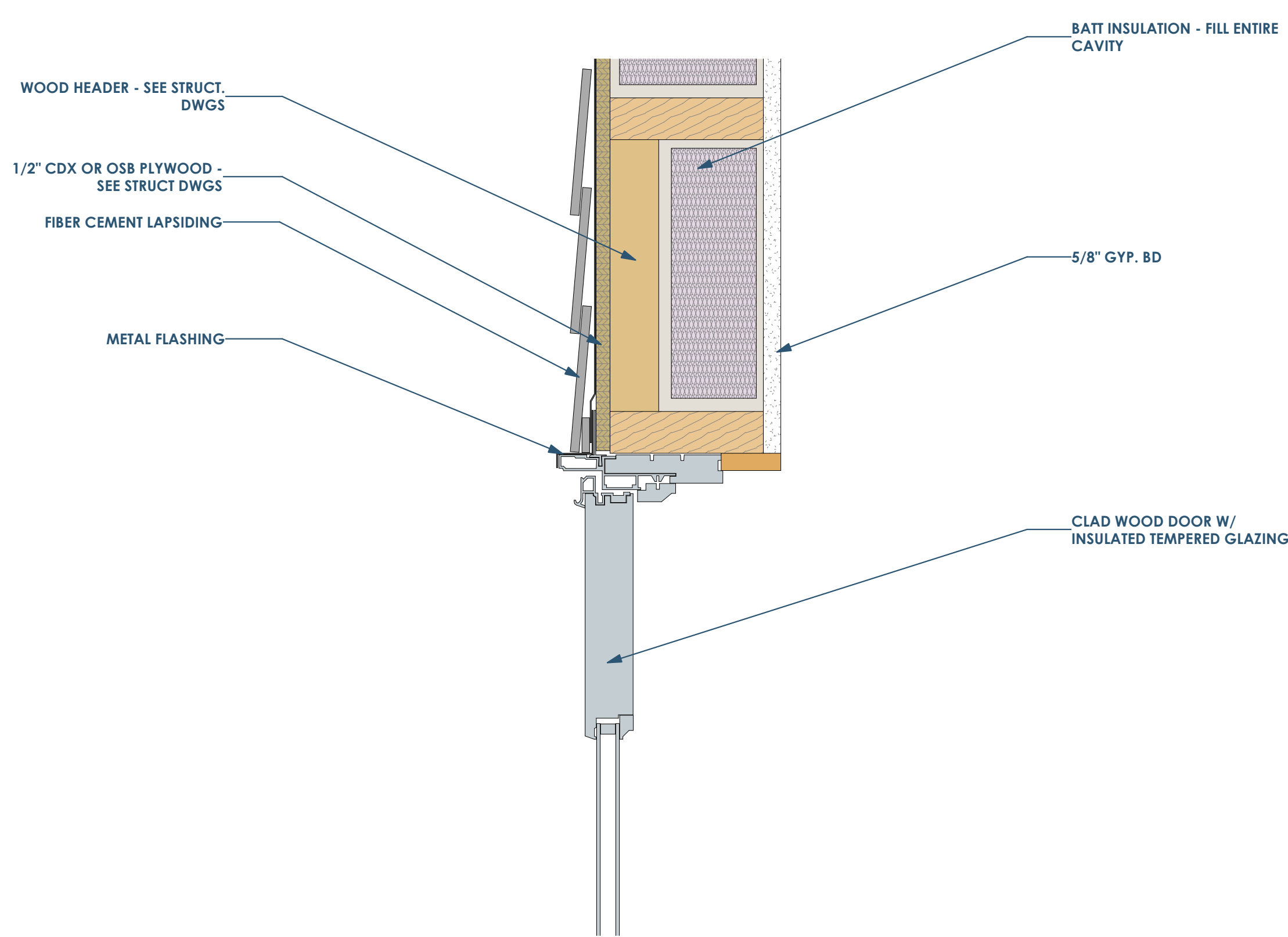

6D A500 SECTION DETAIL AT DOOR HEADER  
3" = 1'-0"

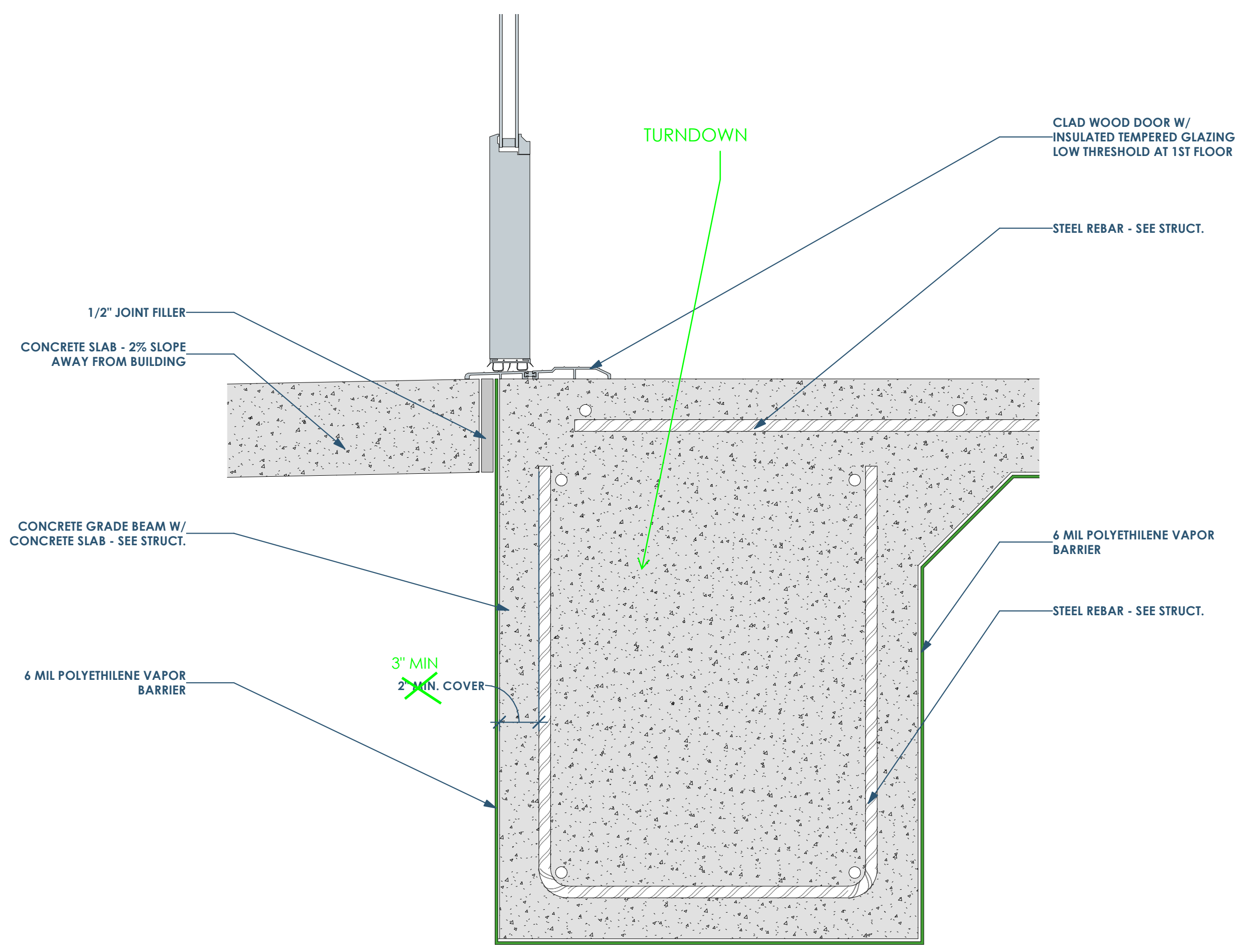

6B A500 SECTION DETAIL AT DOOR SILL - 1ST FLOOR  
3" = 1'-0"

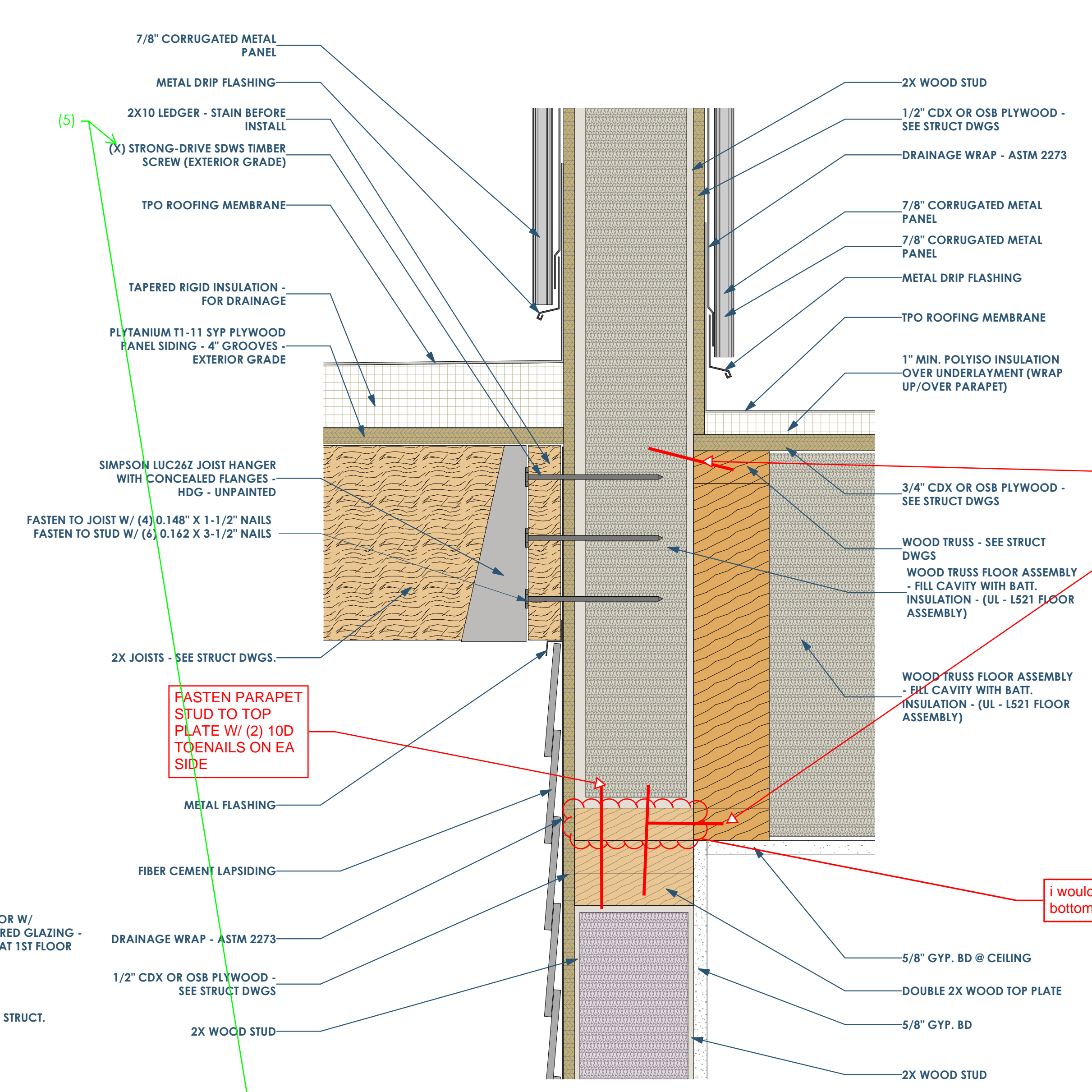

4C A500 SECTION DETAIL AT PORCH ROOF AND PARAPET  
3" = 1'-0"

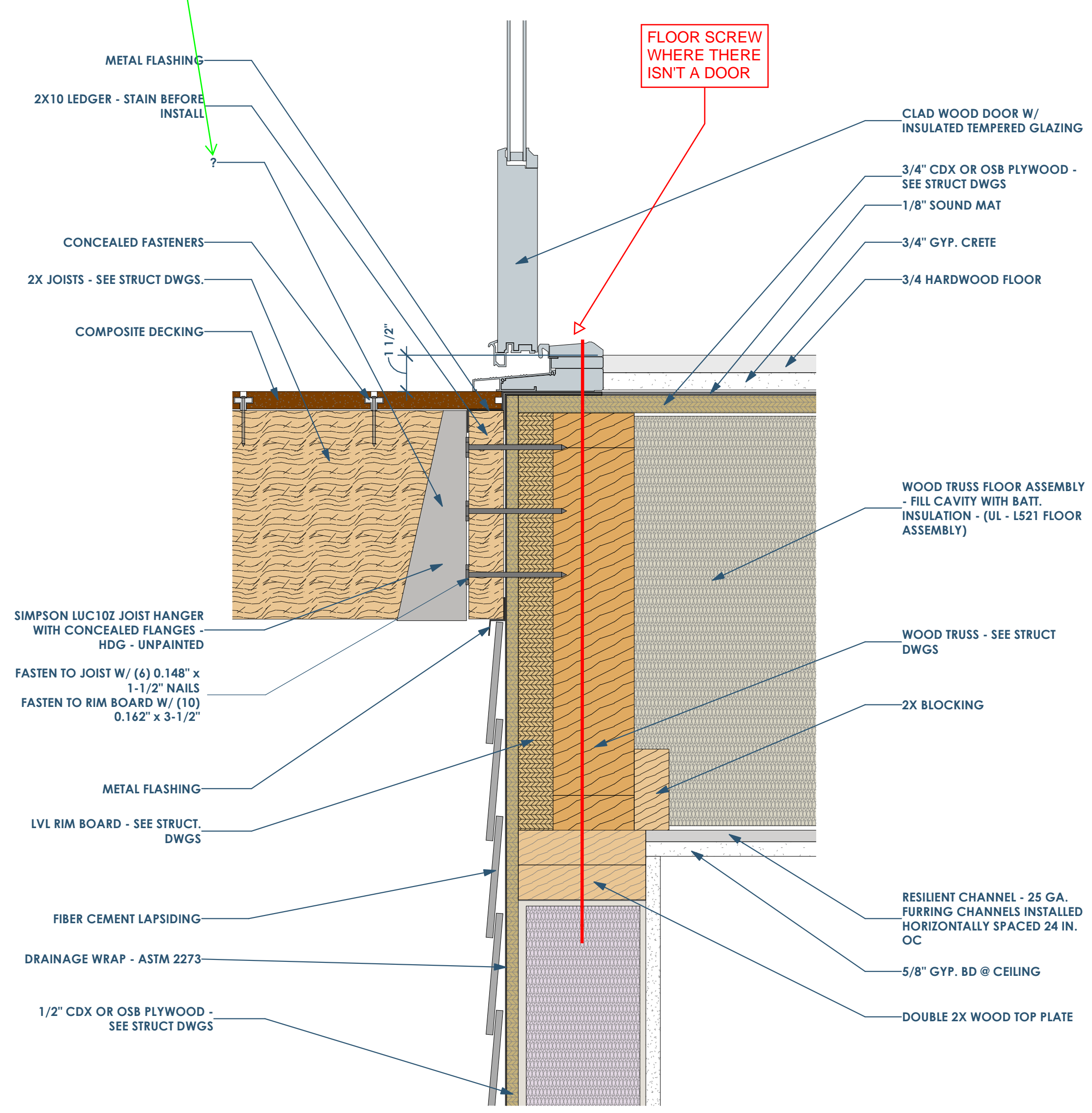

6A A500 SECTION DETAIL AT UNIT DOOR SILL (2ND OR 3RD FLOOR)  
3" = 1'-0"

TOENAIL PARAPET STUD TO TRUSS TOP AND BOTTOM CHORD W/ (1) 10D TOENAILS ON EA SIDE OF STUD

FASTEN PARAPET STUD TO TOP PLATE W/ (2) 10D TOENAILS ON EA SIDE

i would remove this bottom plate

FLOOR SCREW WHERE THERE ISN'T A DOOR

This project, like most OpeningDesign's projects, is open source (Attribution-ShareAlike 4.0 International-CC BY-SA 4.0)-freely available to any party for future use, assuming the terms such as Attribution and ShareAlike are honored.

Date	Description
05.19.2022	Progress Set

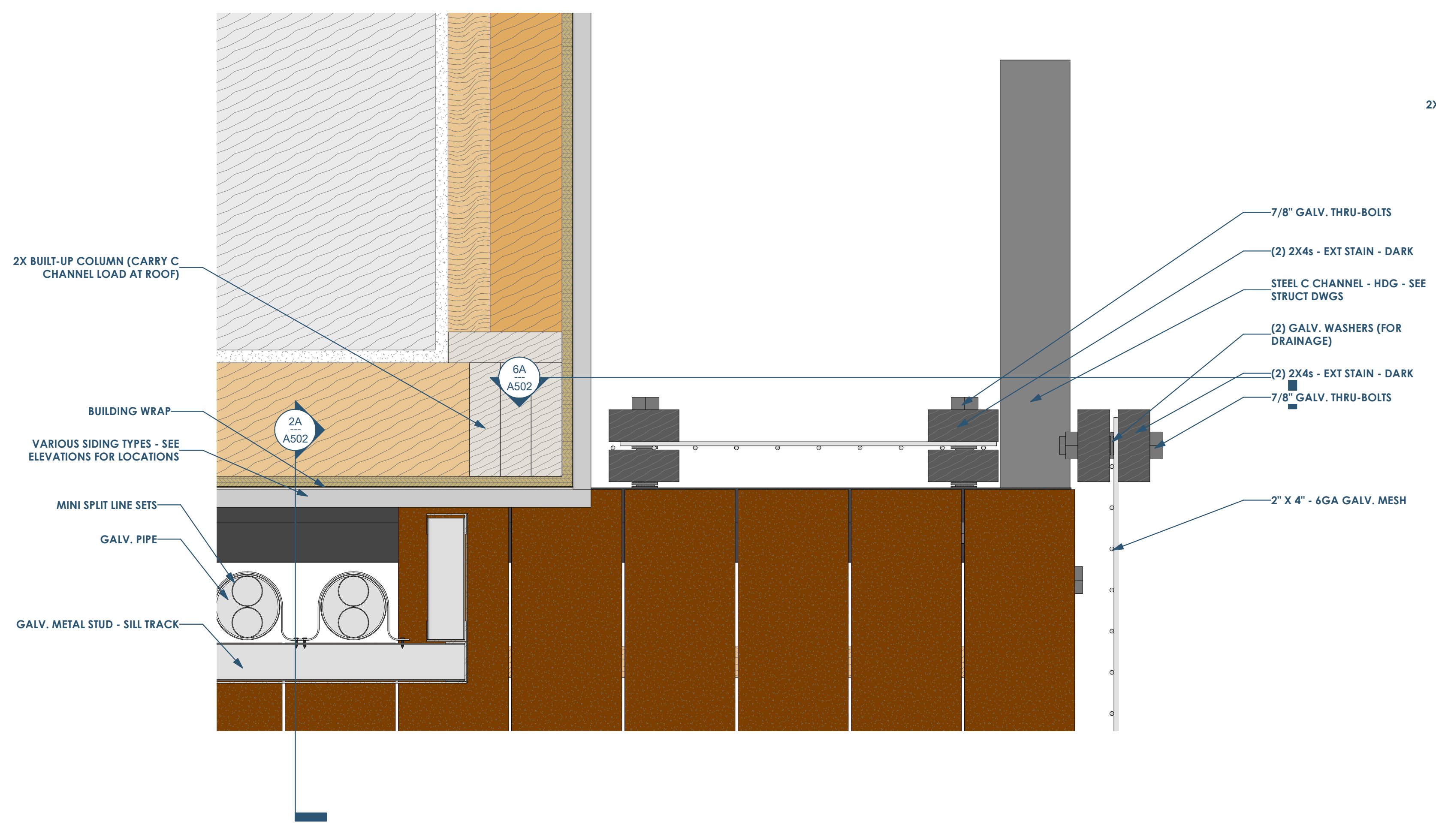

6C A501 PLAN DETAIL AT SOUTH BALCONY - ABOVE DECKING  
3" = 1'-0"

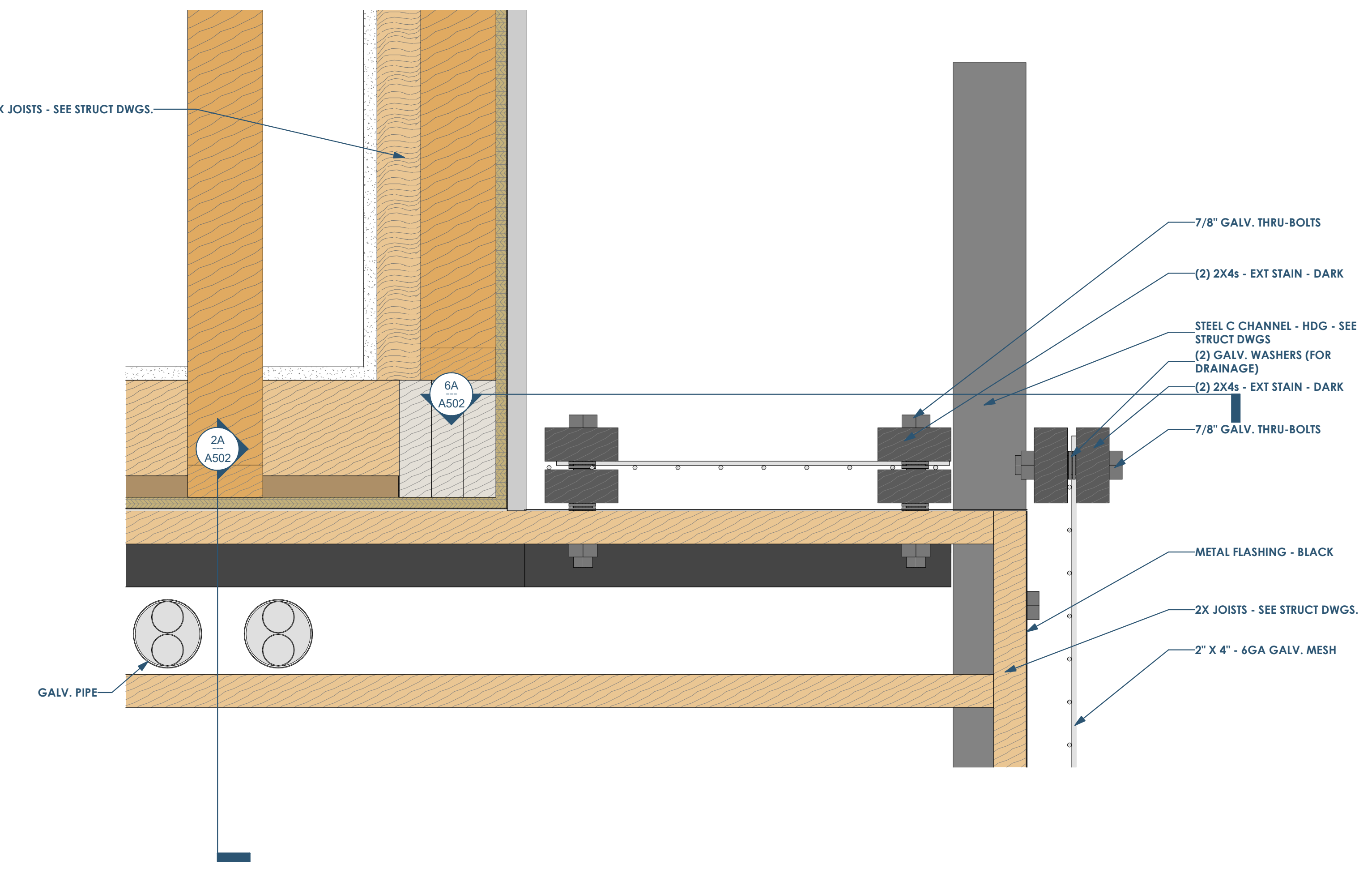

3C A501 PLAN DETAIL AT SOUTH BALCONY - AT LEDGER  
3" = 1'-0"

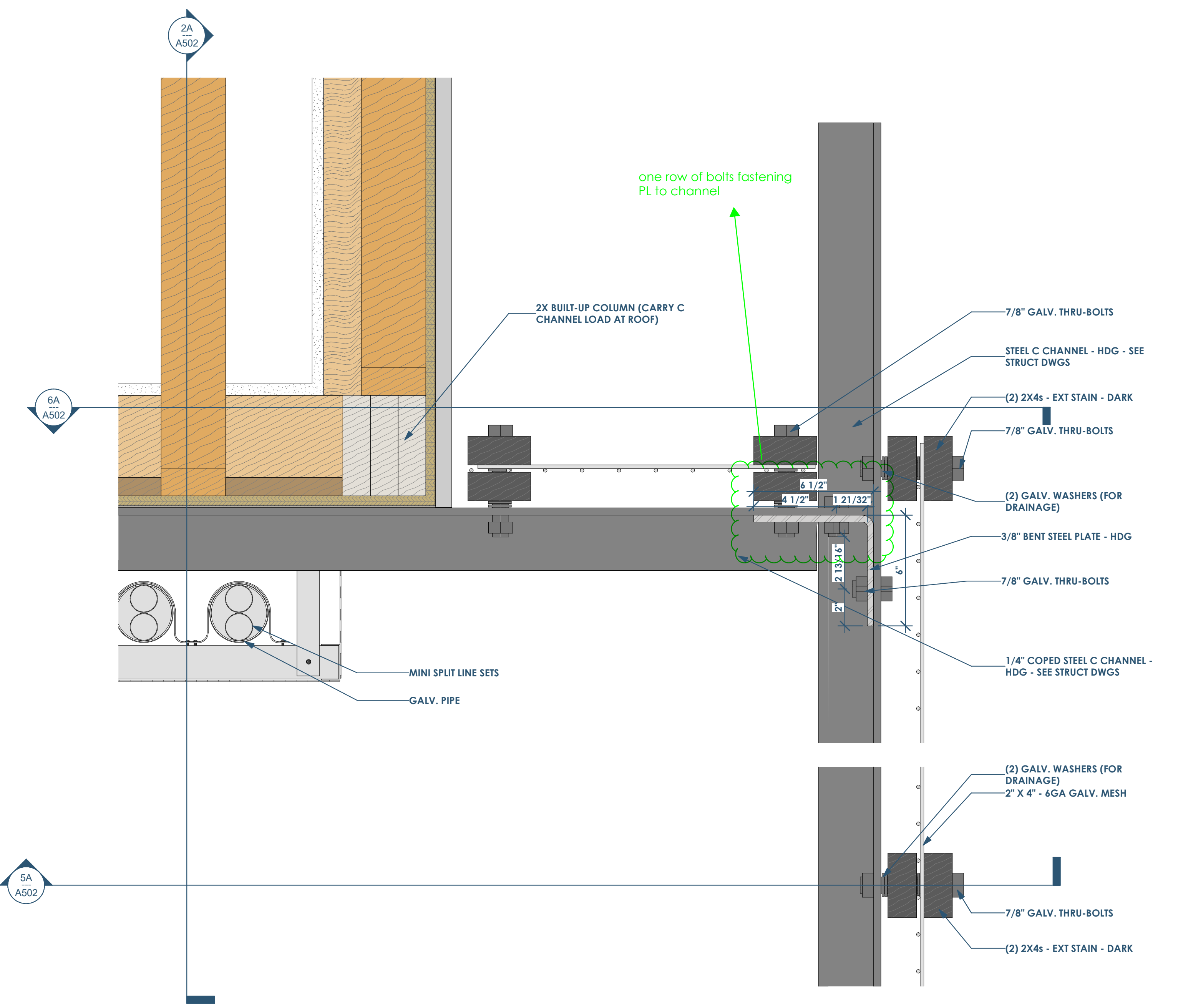

3A A501 PLAN DETAIL AT SOUTH BALCONY - AT STEEL  
3" = 1'-0"



This project, like most OpeningDesign's projects, is open source (Attribution-ShareAlike 4.0 International-CC BY-SA 4.0)-freely available to any party for future use, assuming the terms such as Attribution and ShareAlike are honored.

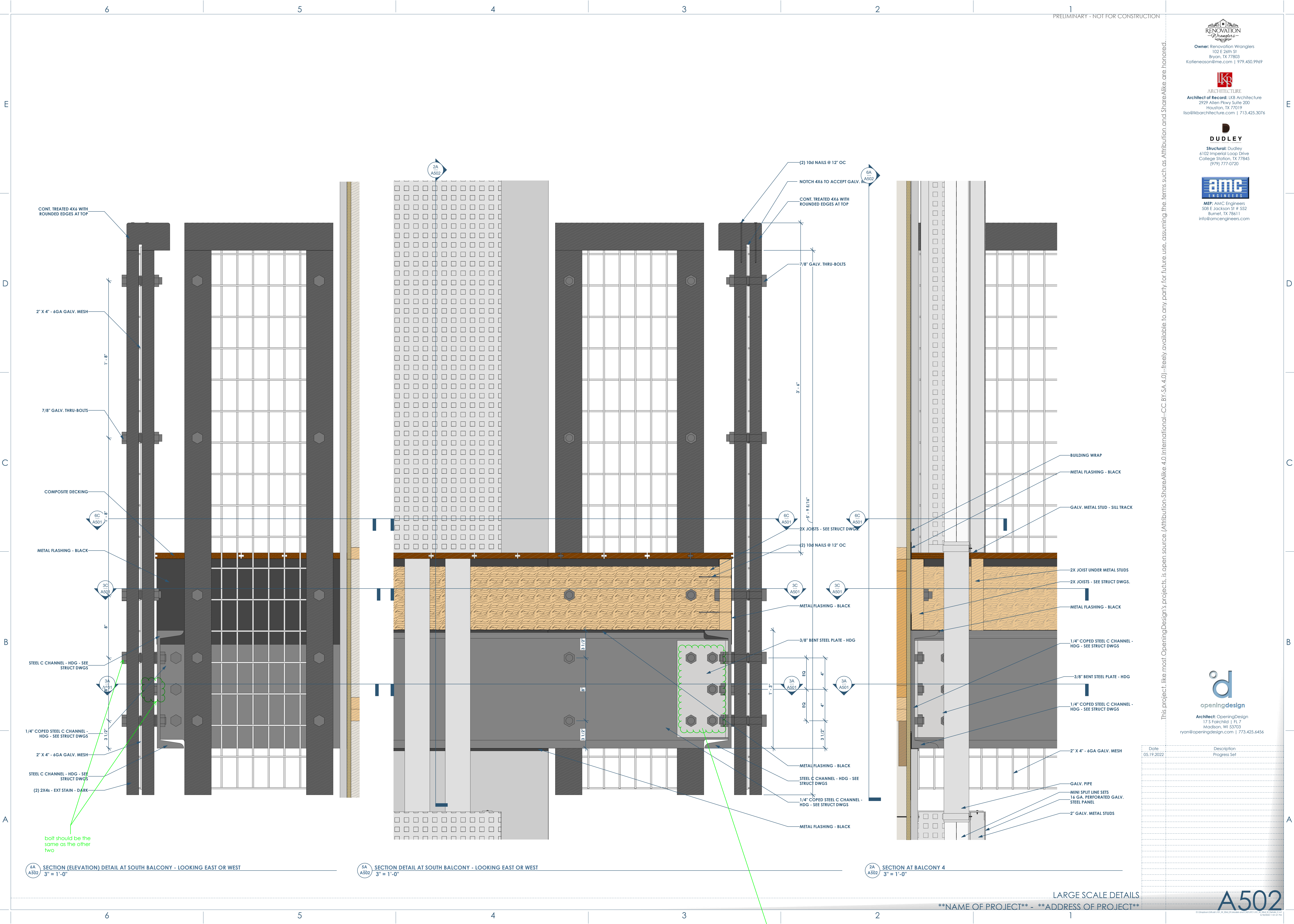

6A A502 SECTION (ELEVATION) DETAIL AT SOUTH BALCONY - LOOKING EAST OR WEST  
3" = 1'-0"

5A A502 SECTION DETAIL AT SOUTH BALCONY - LOOKING EAST OR WEST  
3" = 1'-0"

2A A502 SECTION AT BALCONY 4  
3" = 1'-0"

Date	Description
05.19.2022	Progress Set

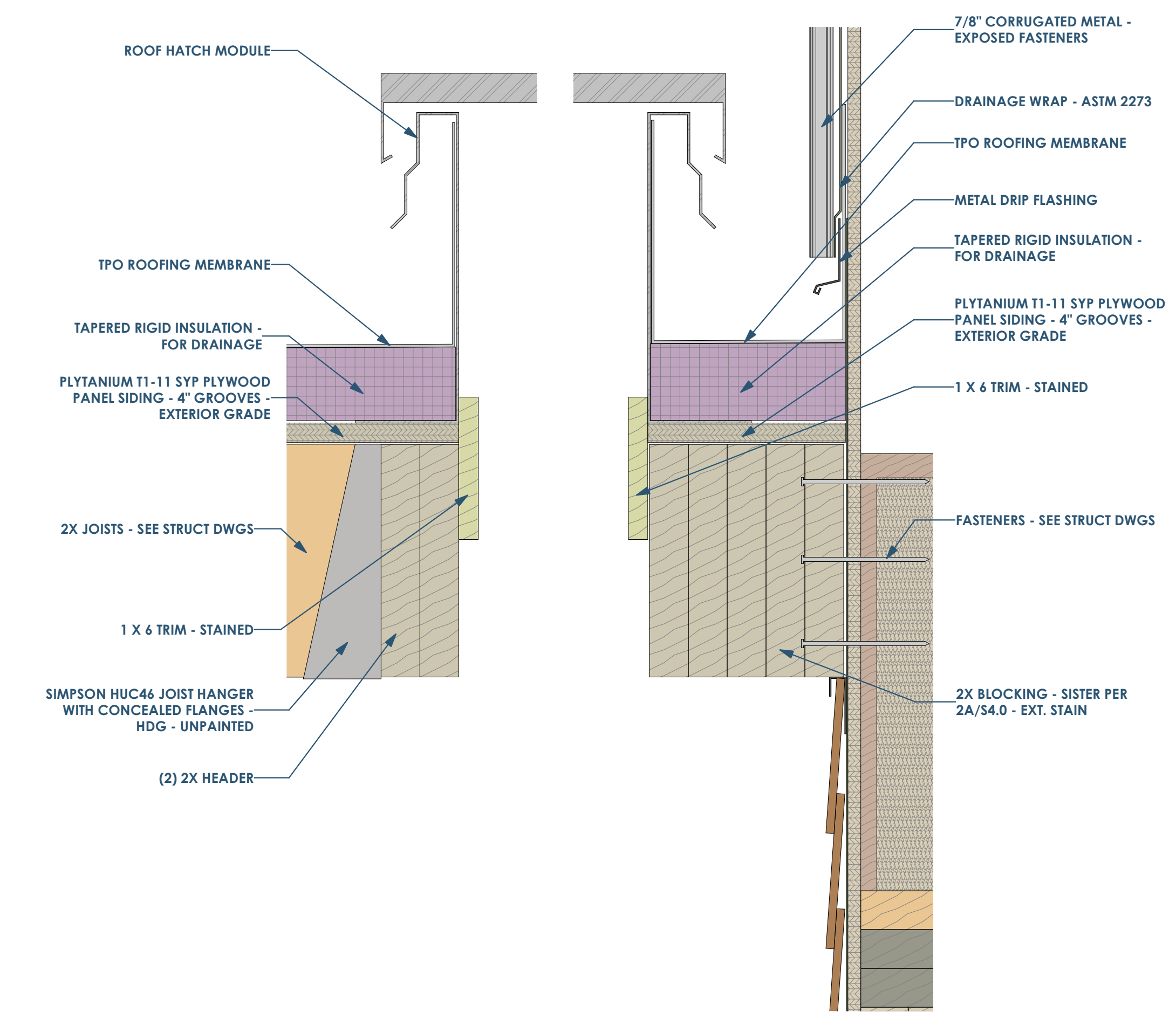

2C SECTION DETAIL - ROOF HATCH  
3\"/>

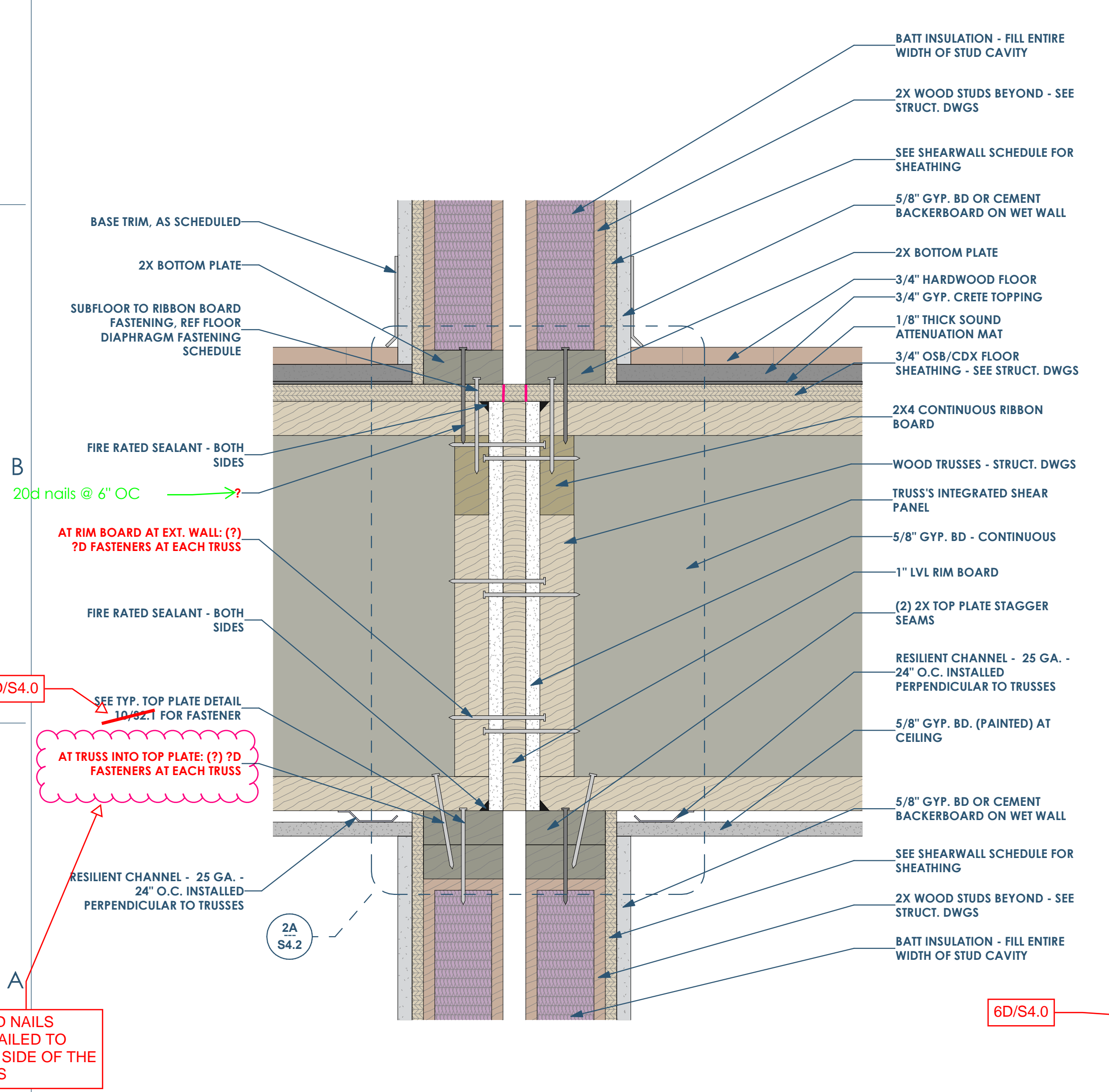

6A SECTION DETAIL - PARTY WALL AND FLOOR TRUSS  
3\"/>

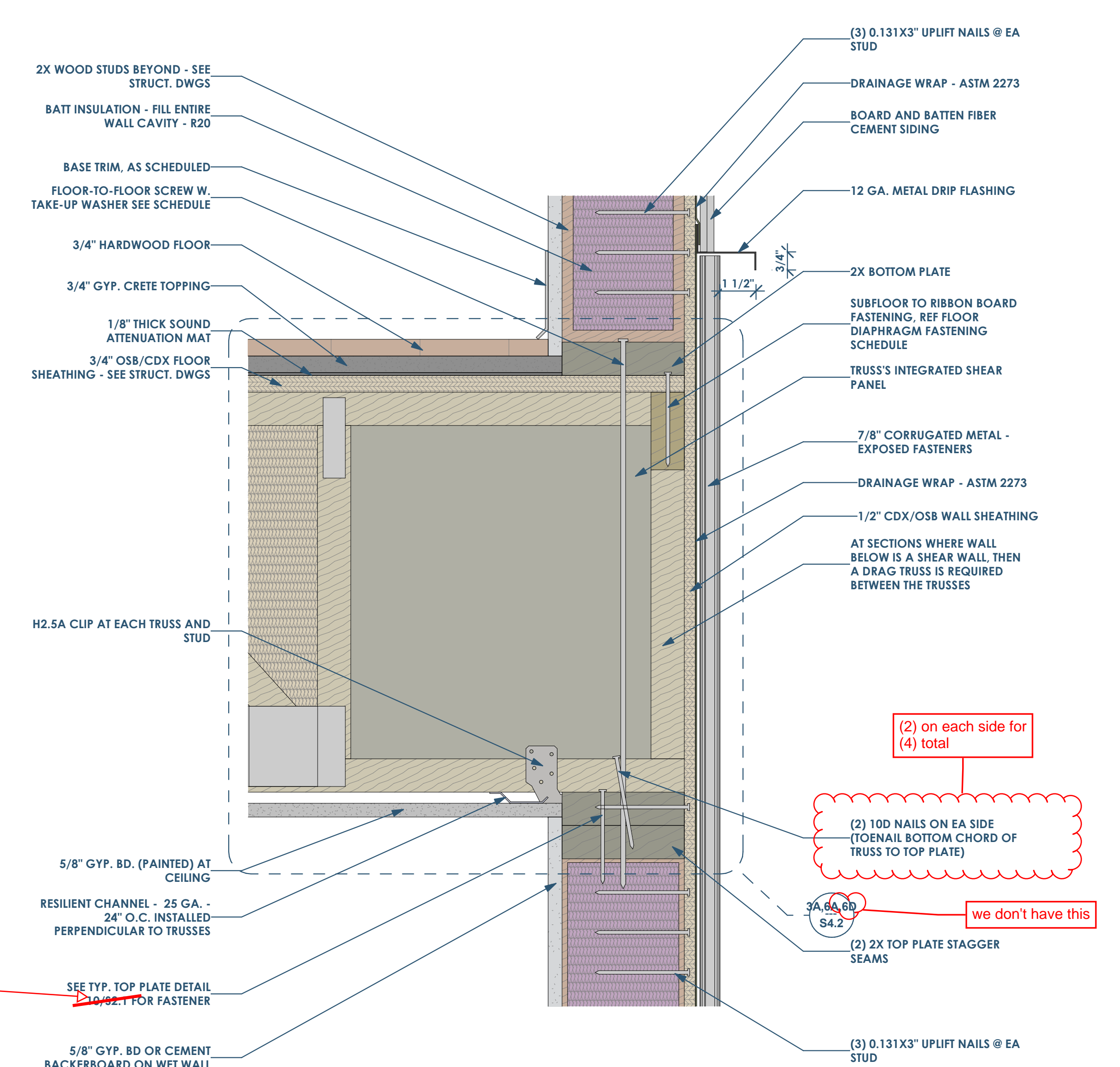

4A SECTION DETAIL - EXTERIOR WALL & FLOOR TRUSS  
3\"/>

This project, like most OpeningDesign's projects, is open source (Attribution-ShareAlike 4.0 International)-CC BY-SA 4.0)-freely available to any party for future use, assuming the terms such as Attribution and ShareAlike are honored.

Date	Description
05.19.2022	Progress Set

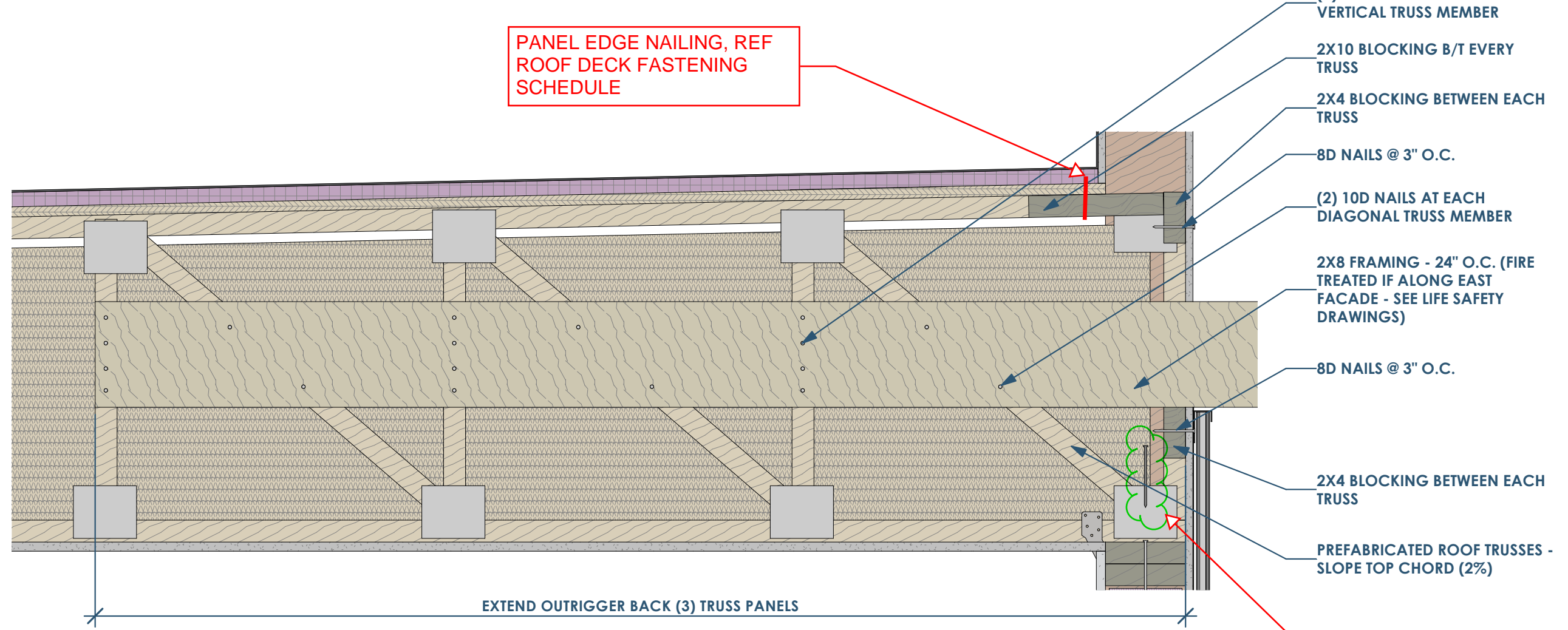

SECTION DETAIL AT OUTRIGGER 1 1/2" = 1'-0"

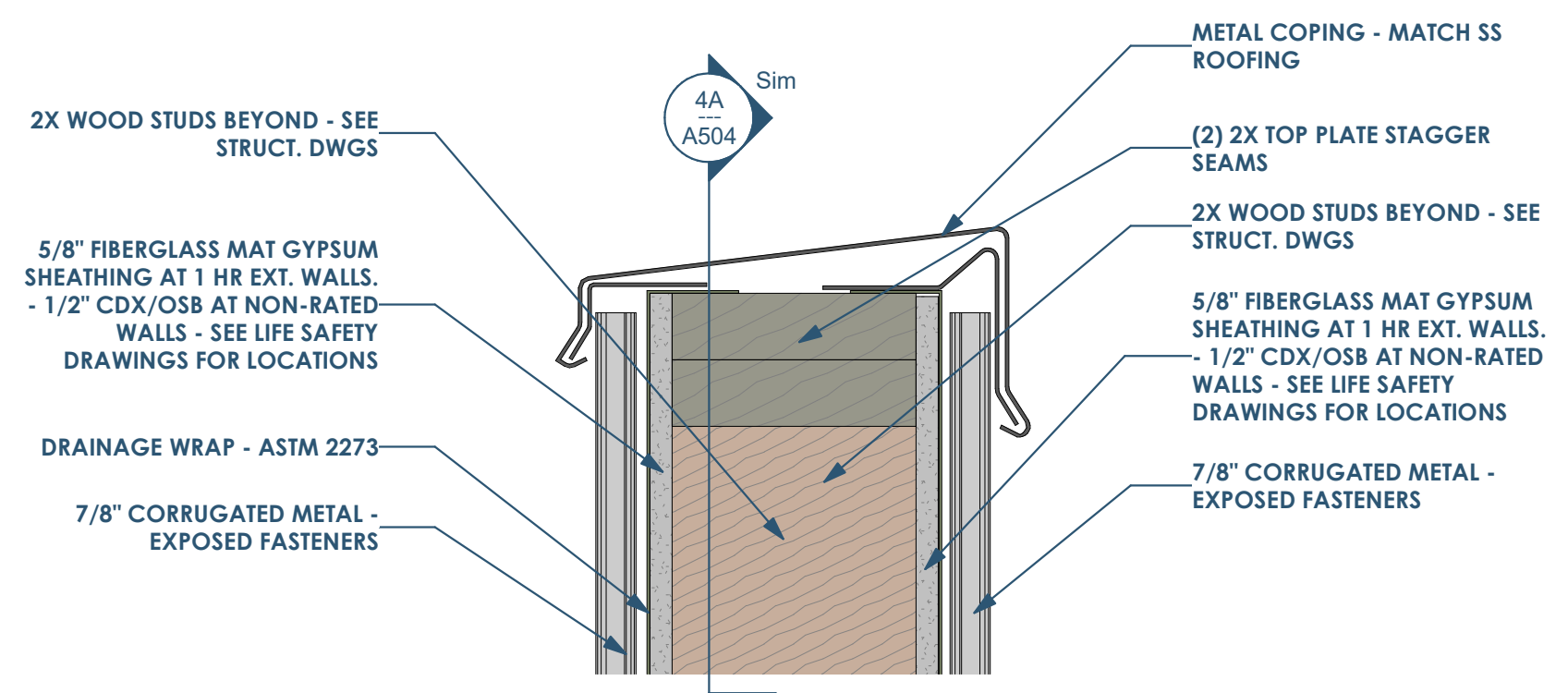

SECTION DETAIL - TOP OF PARAPET 3" = 1'-0"

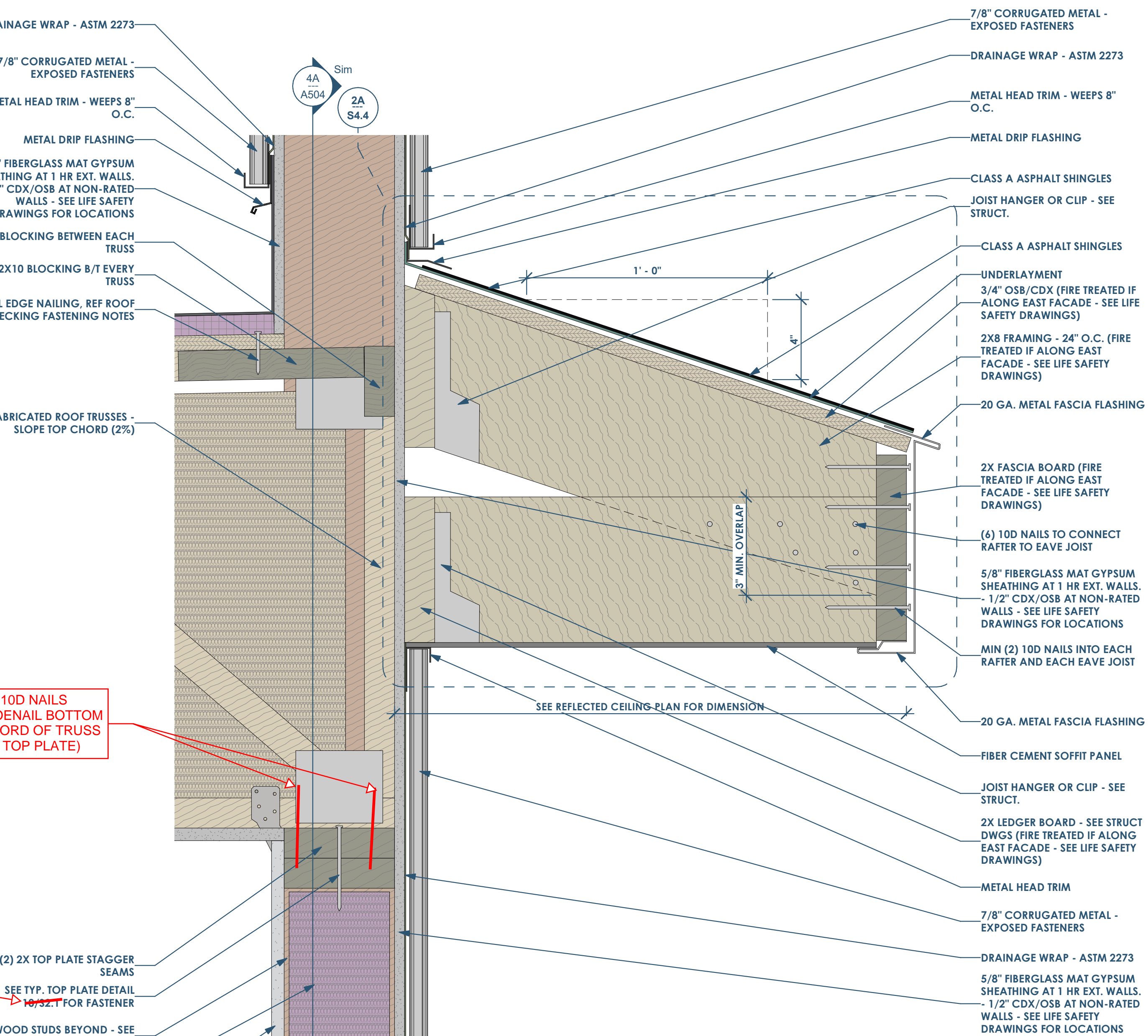

SECTION DETAIL - AT PARAPET WALL 3" = 1'-0"

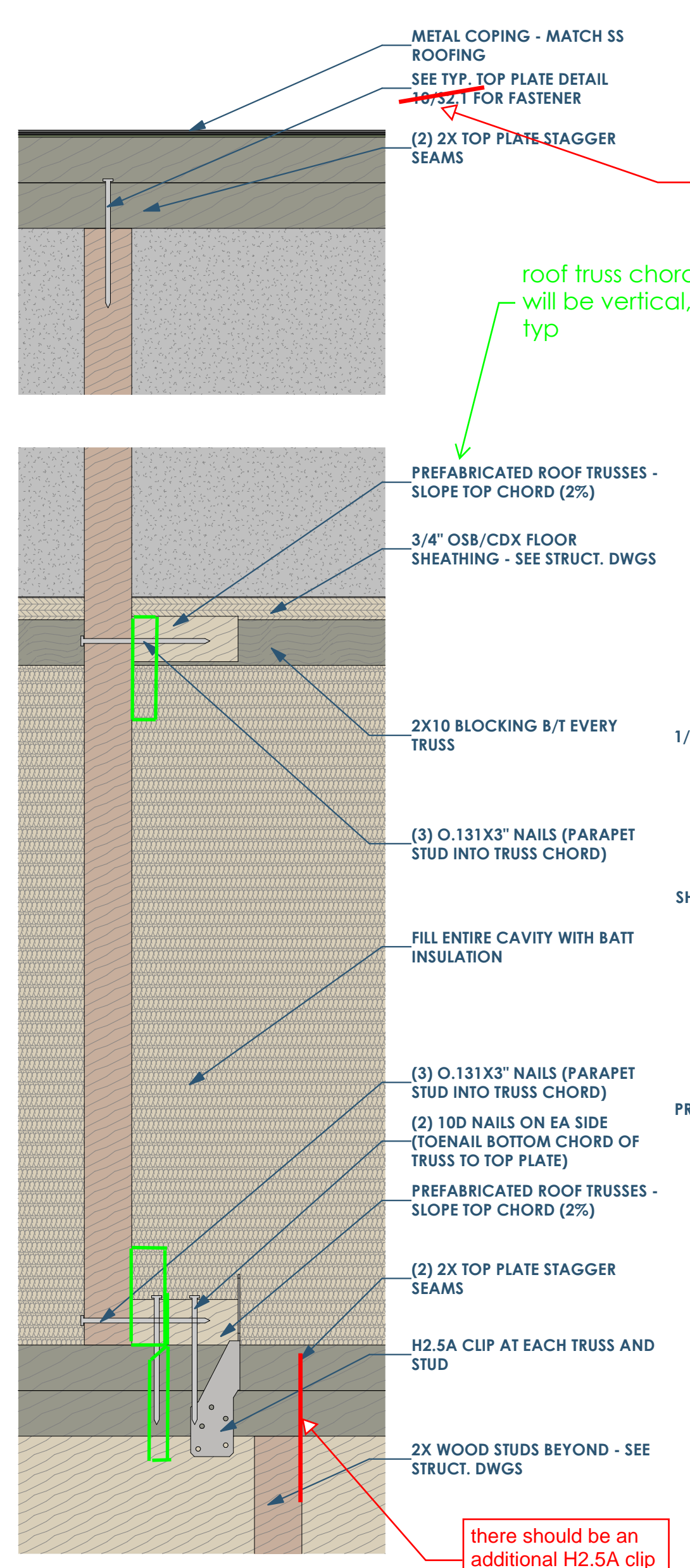

SECTION DETAIL - AT SOFFIT AND RECOVER 3" = 1'-0"

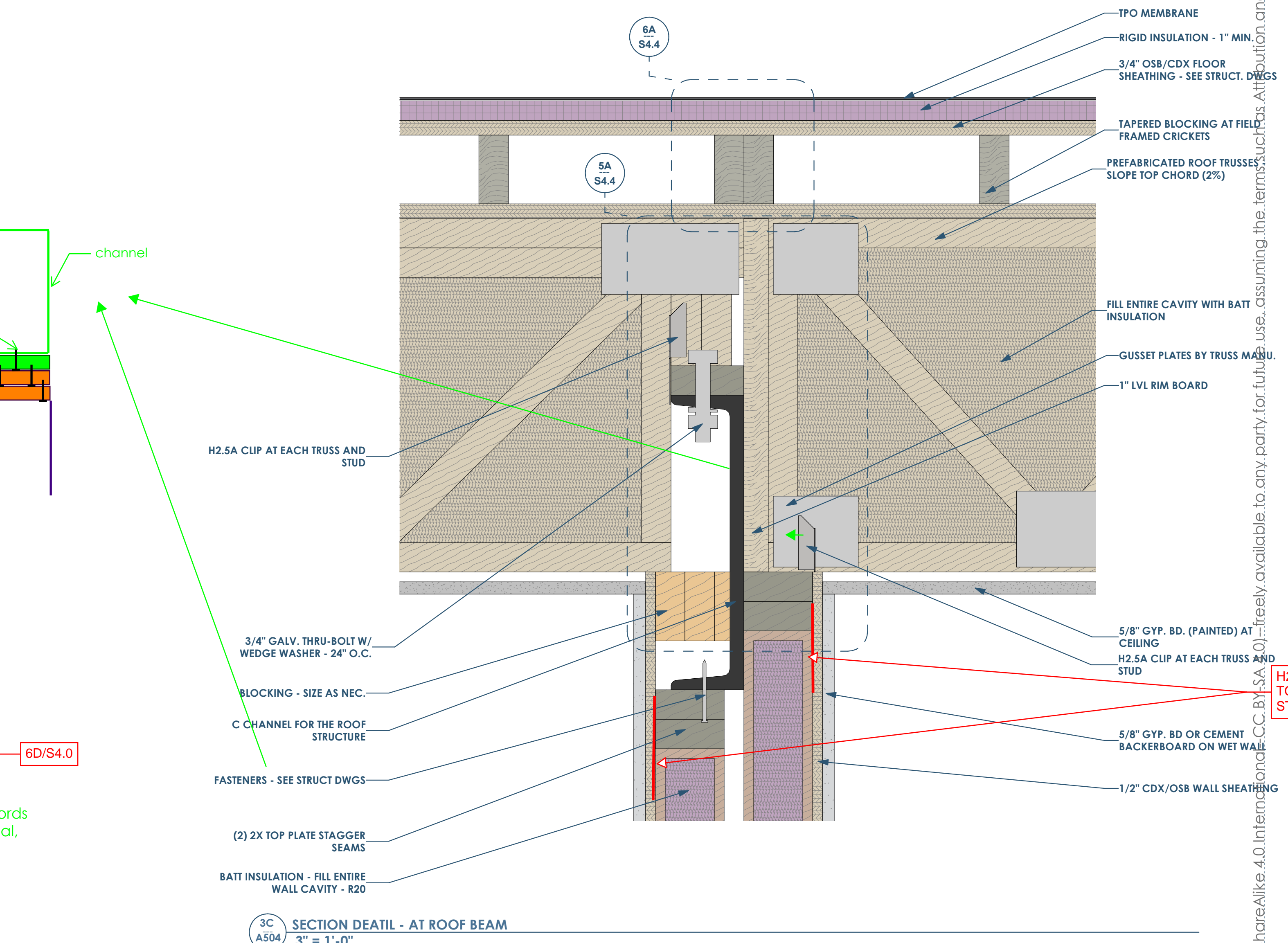

SECTION DETAIL - AT ROOF BEAM 3" = 1'-0"

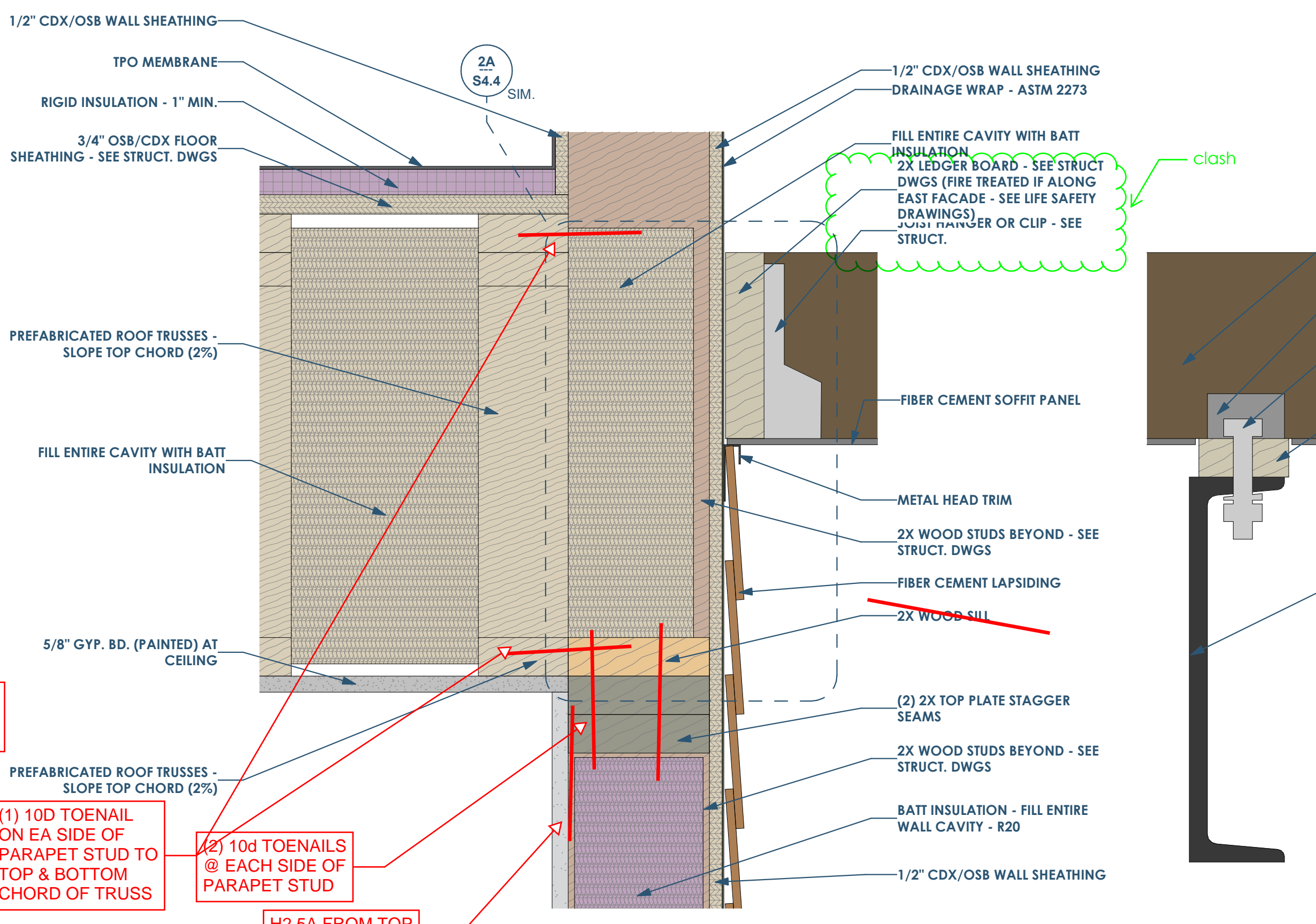

SECTION DETAIL - ALCOVE AT ROOF BEAM 3" = 1'-0"

SECTION DETAIL - ROOF AND SOFFIT 3" = 1'-0"

This project, like most OpeningDesign's projects, is open source. (Attribution-ShareAlike 4.0 International license)

Date: 05.19.2022

Description: Progress Set





**RENOVATION**  
Wranglers  
Architects

Owner: Renovation Wranglers  
102 E 26th St  
Bryan, TX 77803  
Katherine@wranglers.com | 979.450.9969

**ARCHITECTURE**  
Architect of Record: LKB Architecture  
2929 Allen Pkwy Suite 200  
Houston, TX 77019  
isa@lkbarchitecture.com | 713.425.3076

**DUDDLEY**  
Structural: Dudley  
6102 Imperial Loop Drive  
College Station, TX 77845  
(979) 777-0720

**amc**  
ENGINEERS

MEP: AMC Engineers  
508 E Jackson St # 552  
Burnet, TX 78611  
info@amcengineers.com

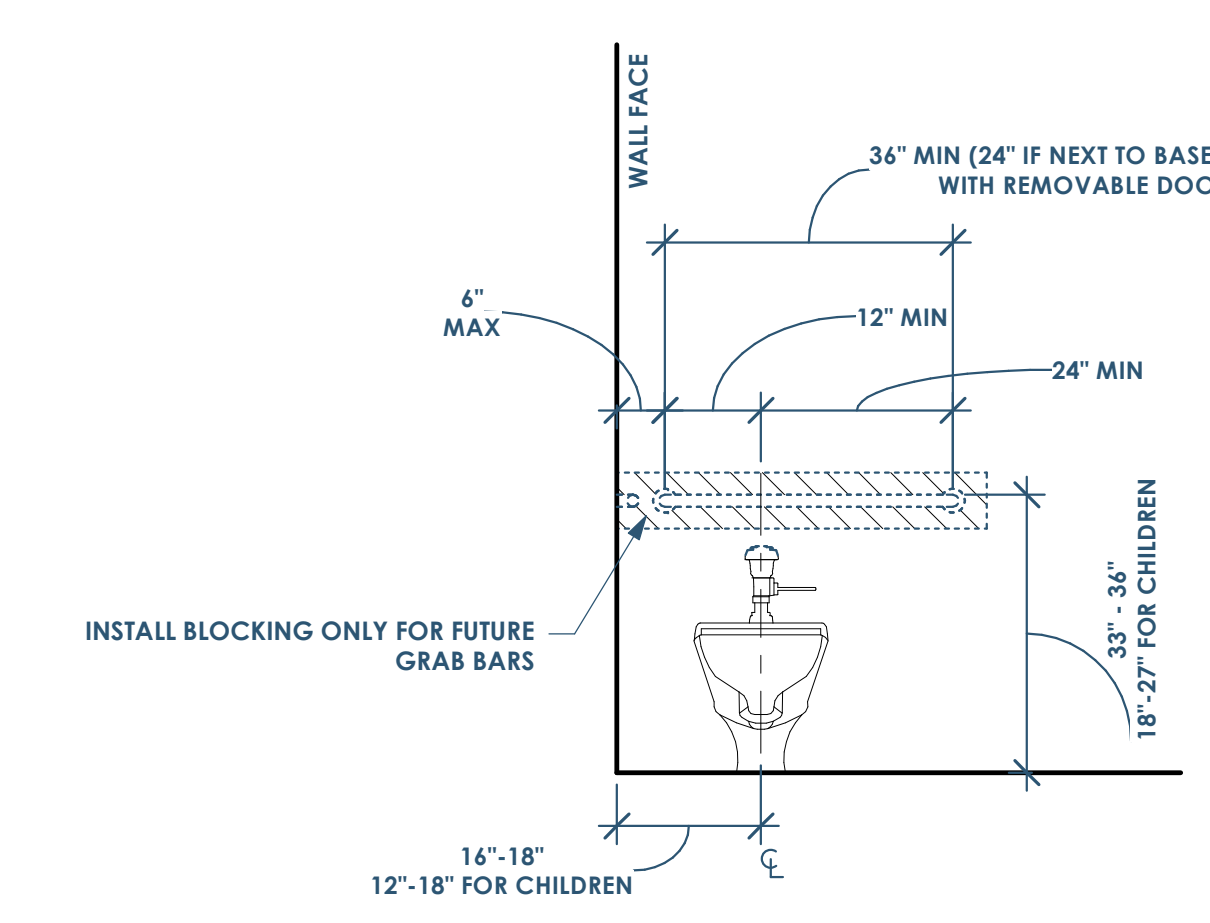

2D ADA - TYPE A - WATER CLOSET - FRONT  
1/2" = 1'-0"

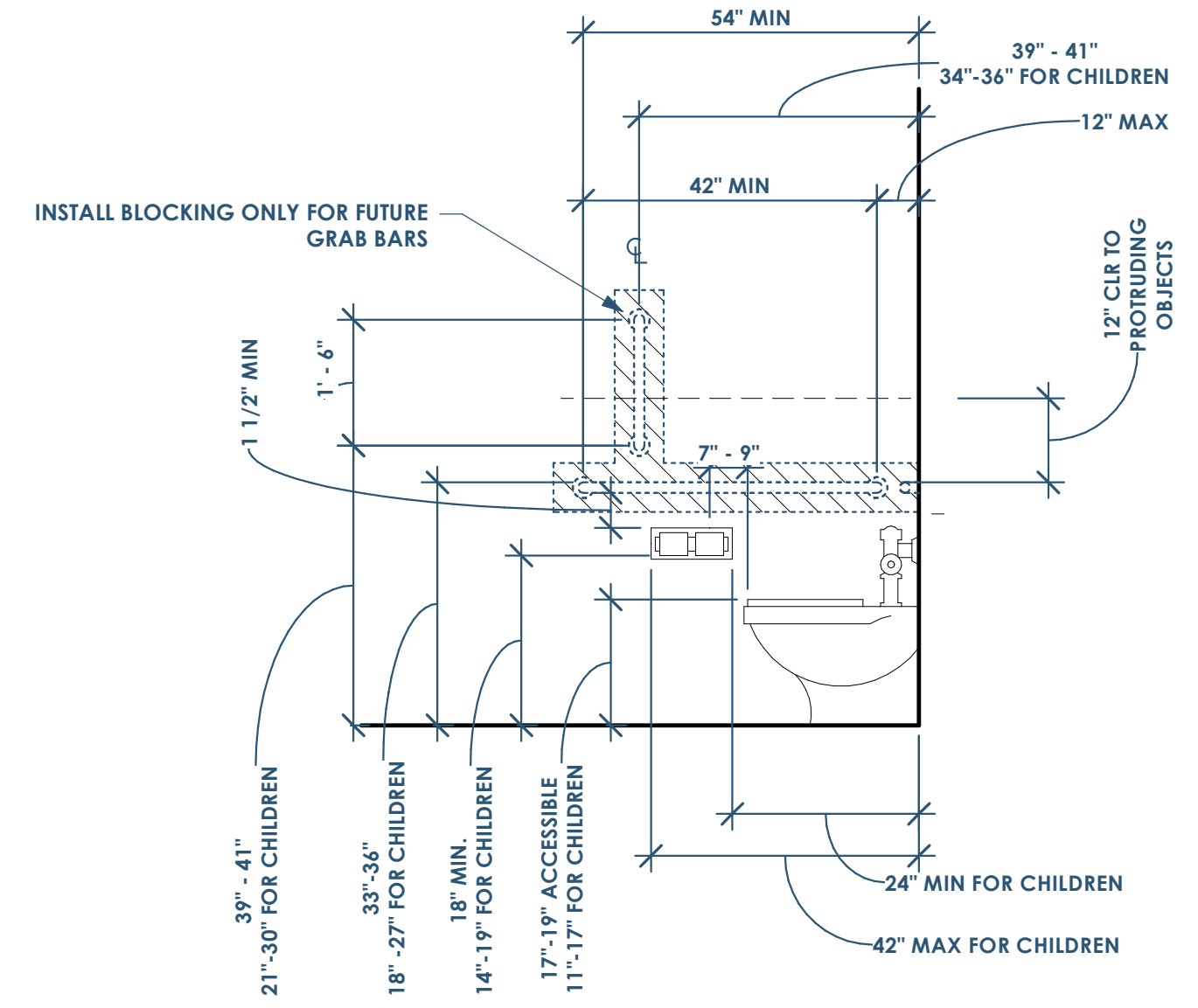

3D ADA - TYPE A - WATER CLOSET - SIDE  
1/2" = 1'-0"

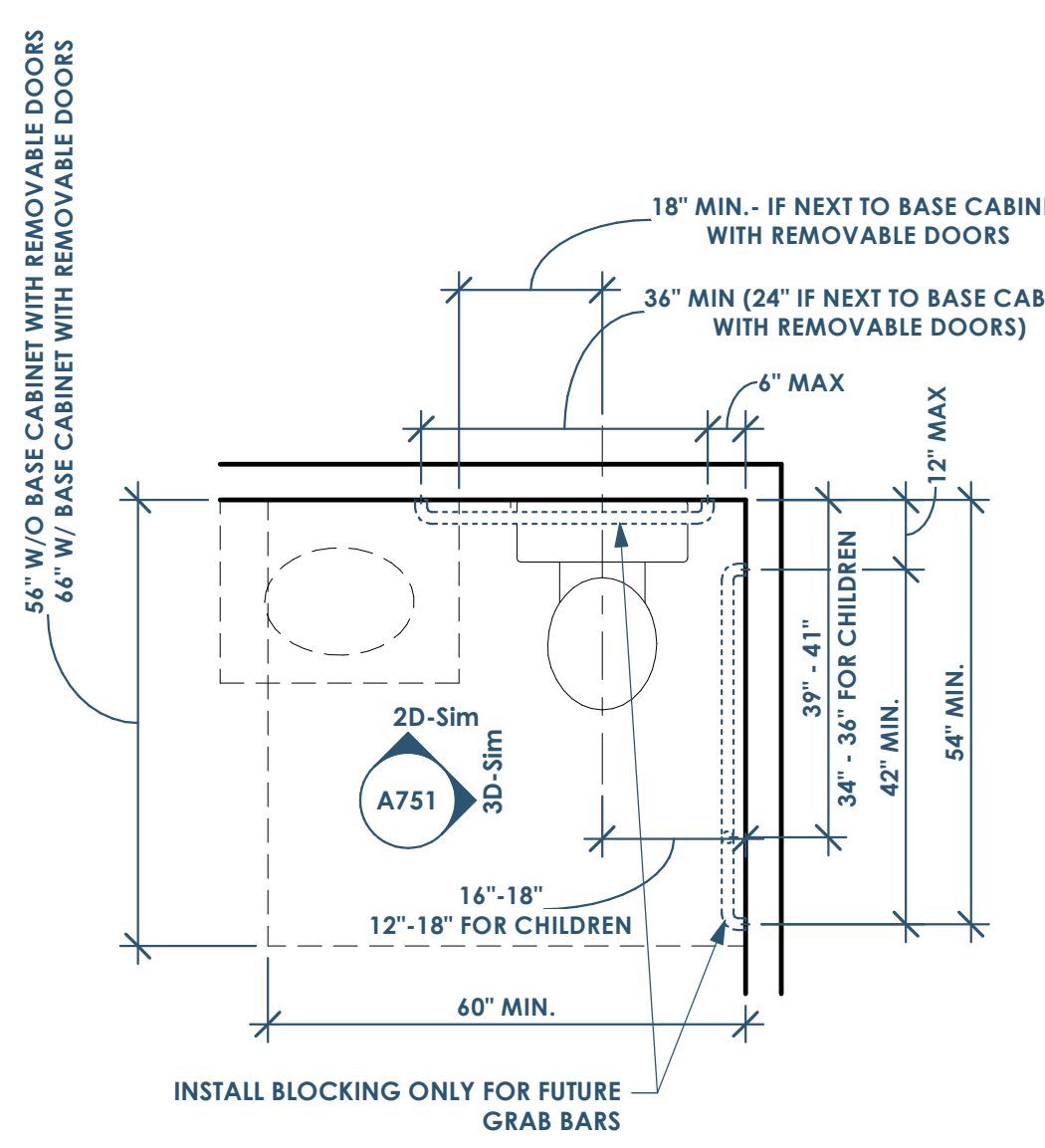

4D ADA - TYPE A - WATER CLOSET - FLOOR PLAN (OR TYPE B FRONT APPROACH)  
1/2" = 1'-0"

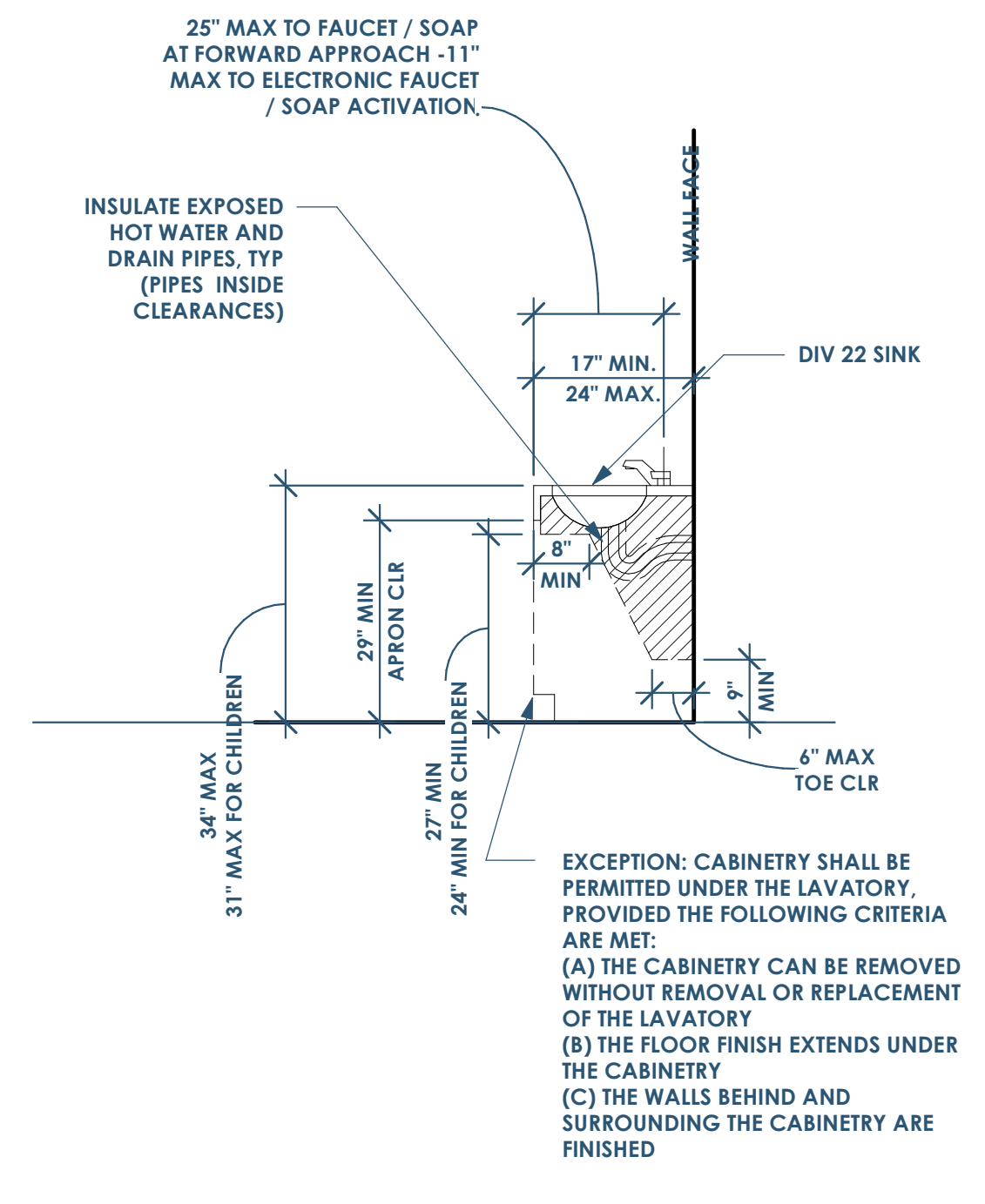

5D ADA - TYPE A - LAVATORY - SIDE (OR TYPE B FRONT APPROACH)  
1/2" = 1'-0"

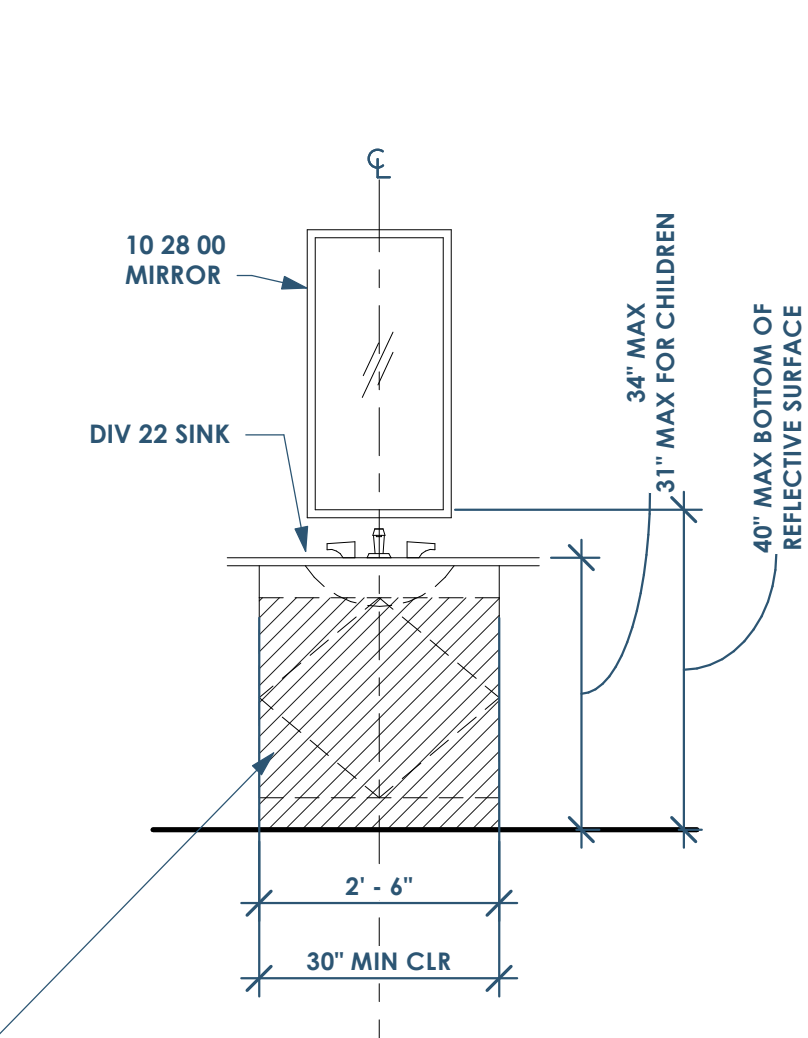

6D ADA - TYPE A - LAVATORY - FRONT (OR TYPE B FRONT APPROACH)  
1/2" = 1'-0"

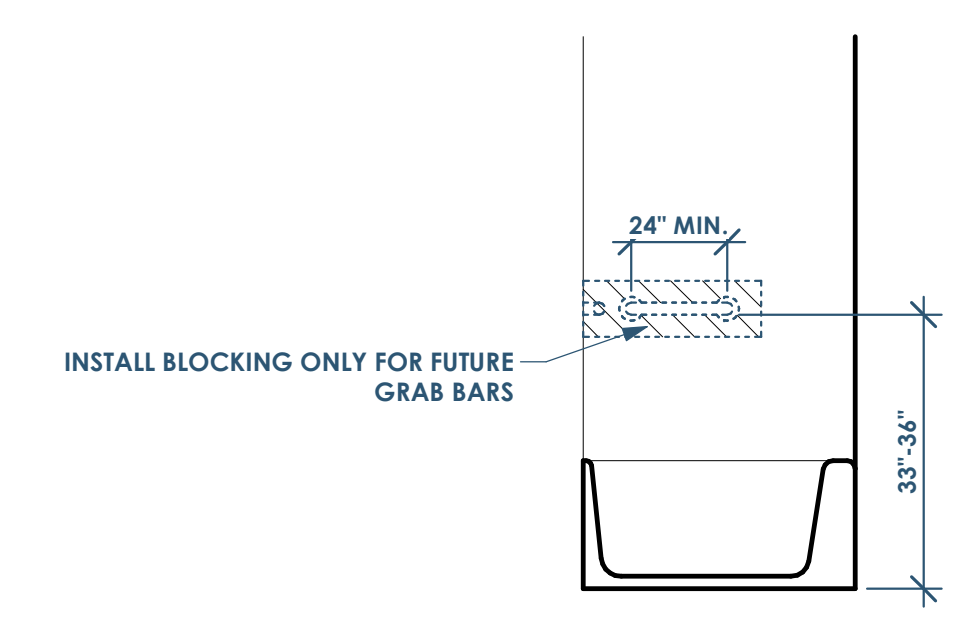

2C ADA - TYPE A & B - BATH - NON-CONTROL SIDE  
1/2" = 1'-0"

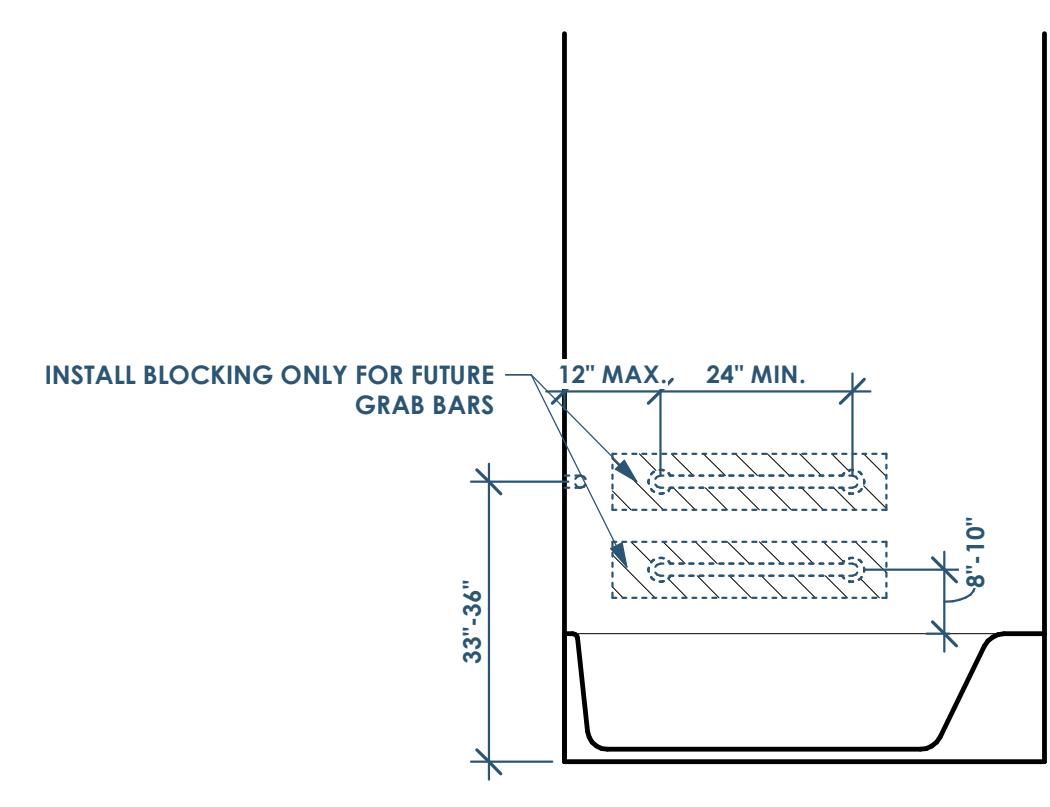

3C ADA - TYPE A & B - BATH - FRONT  
1/2" = 1'-0"

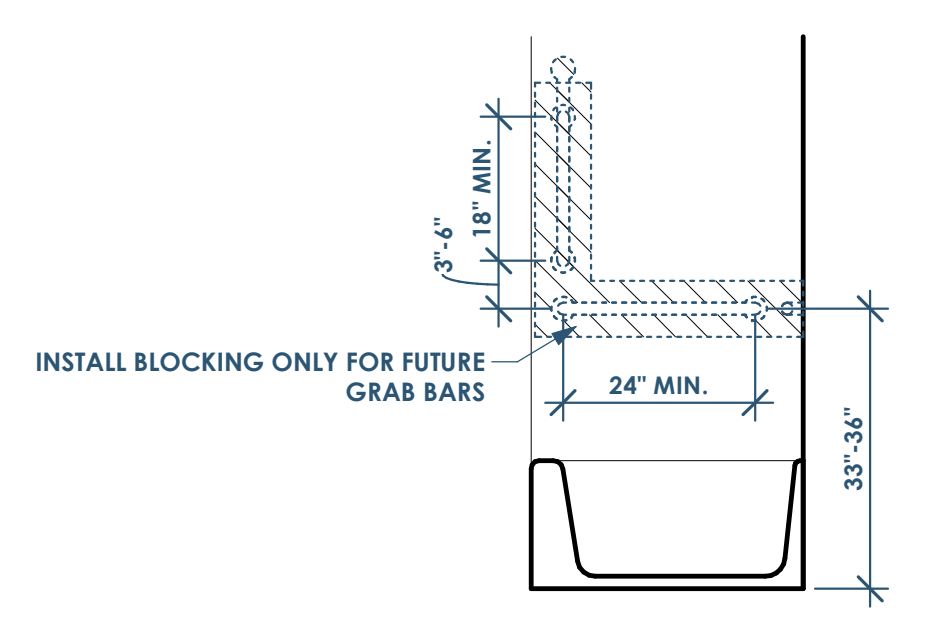

4C ADA - TYPE A & B - BATH - CONTROLS SIDE  
1/2" = 1'-0"

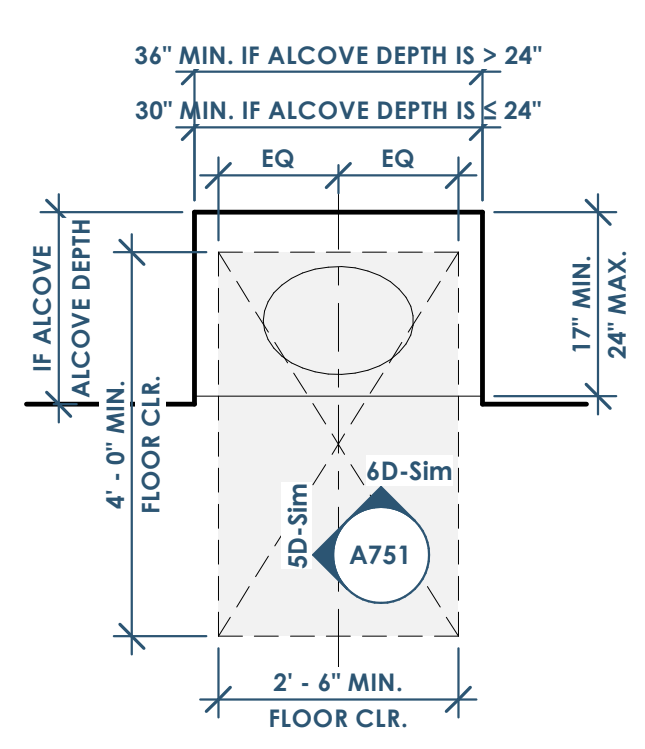

4A ADA - TYPE A - LAVATORY - PLAN  
1/2" = 1'-0"

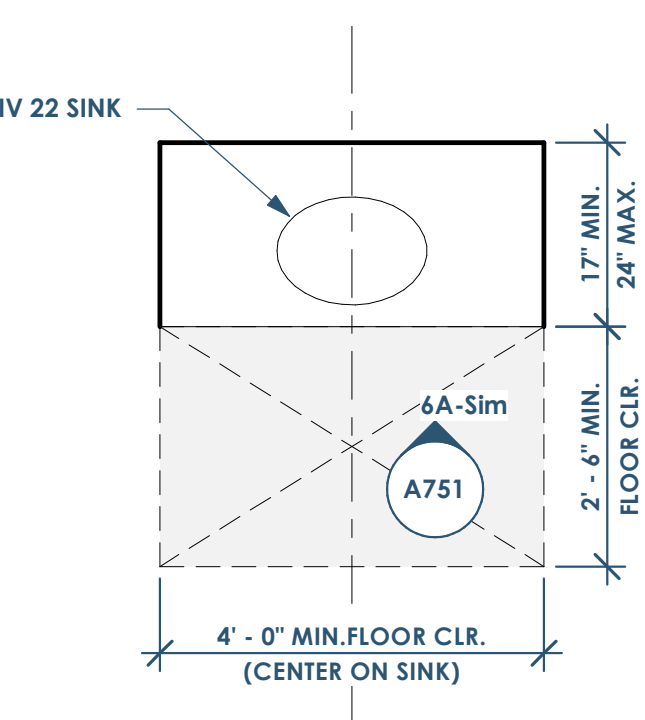

4B ADA - TYPE B - LAVATORY - PLAN  
1/2" = 1'-0"

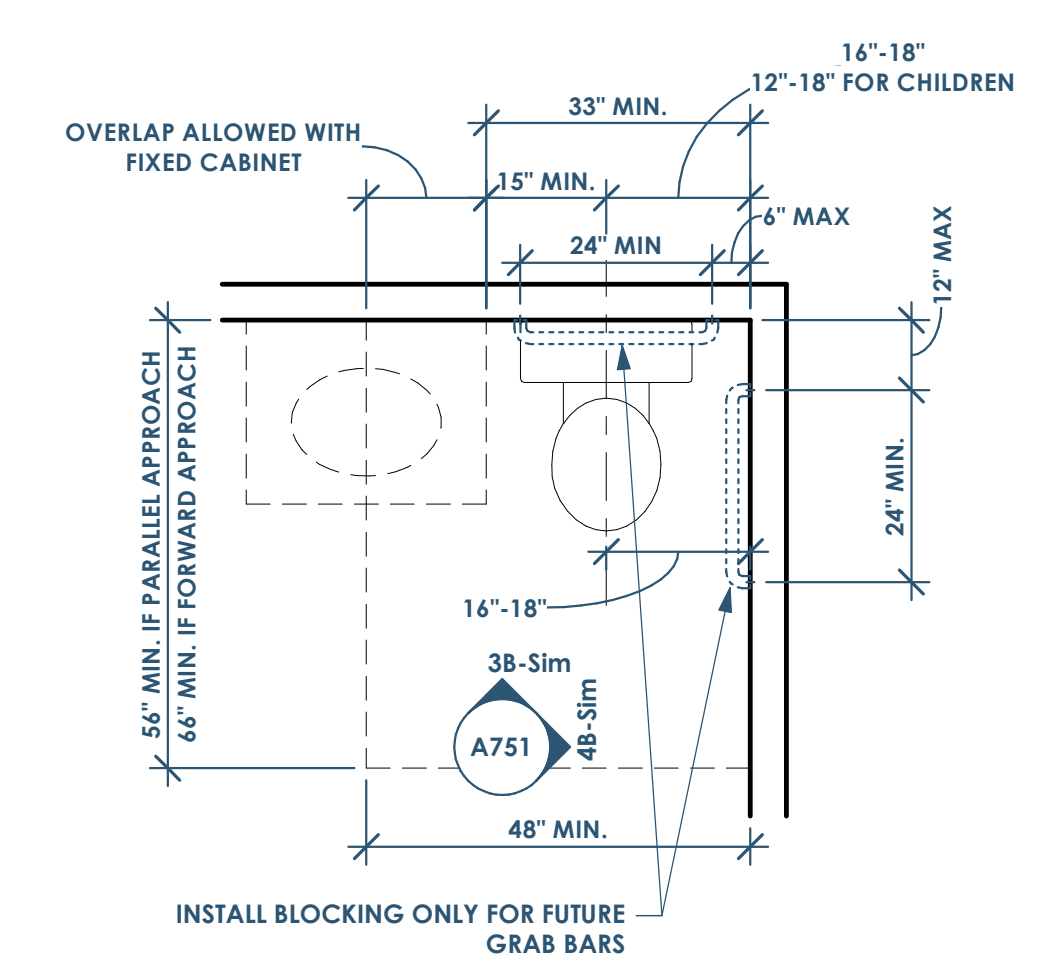

5B ADA - TYPE B - WATER CLOSET - FLOOR PLAN  
1/2" = 1'-0"

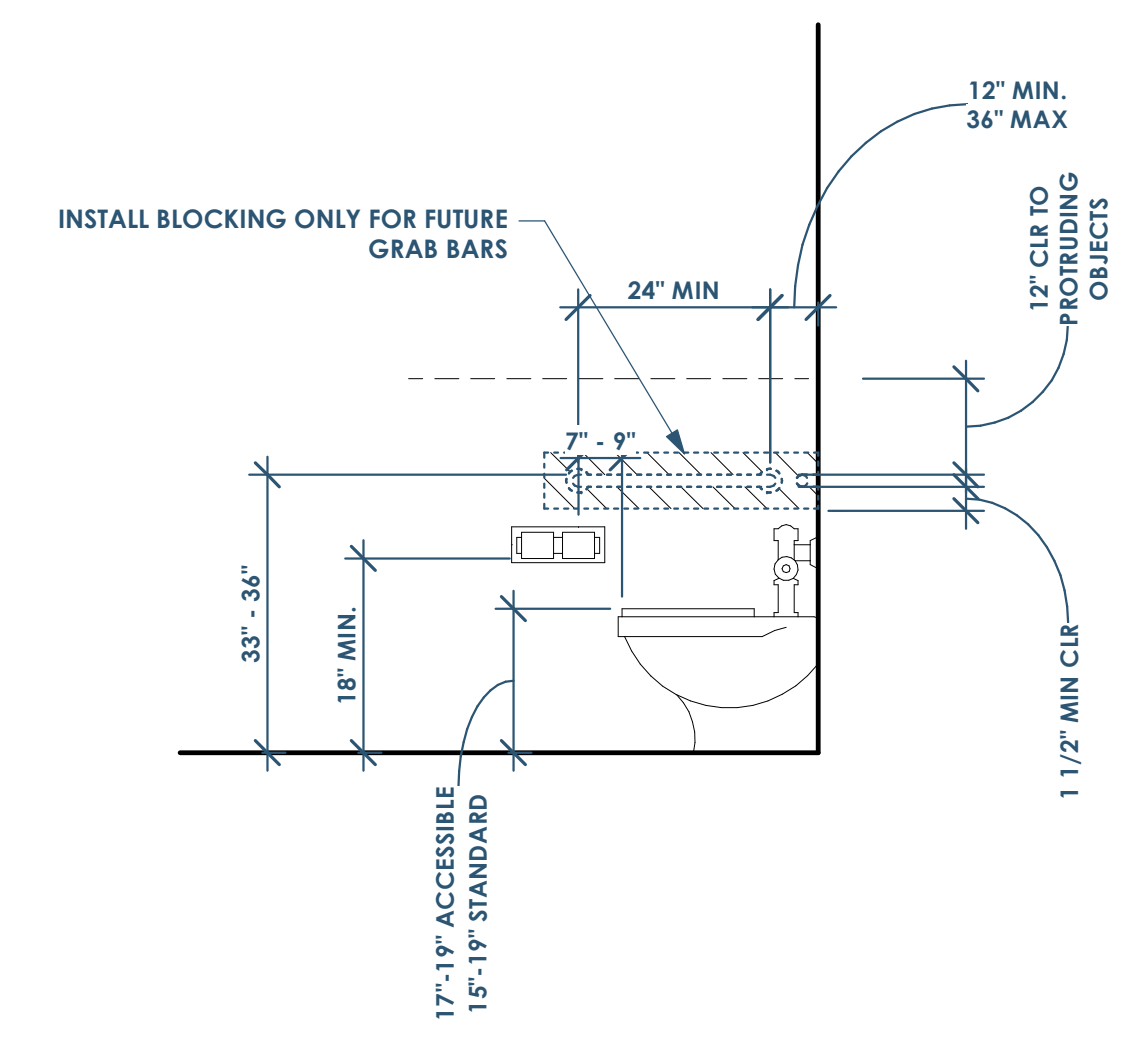

4B ADA - TYPE B - WATER CLOSET - SIDE  
1/2" = 1'-0"

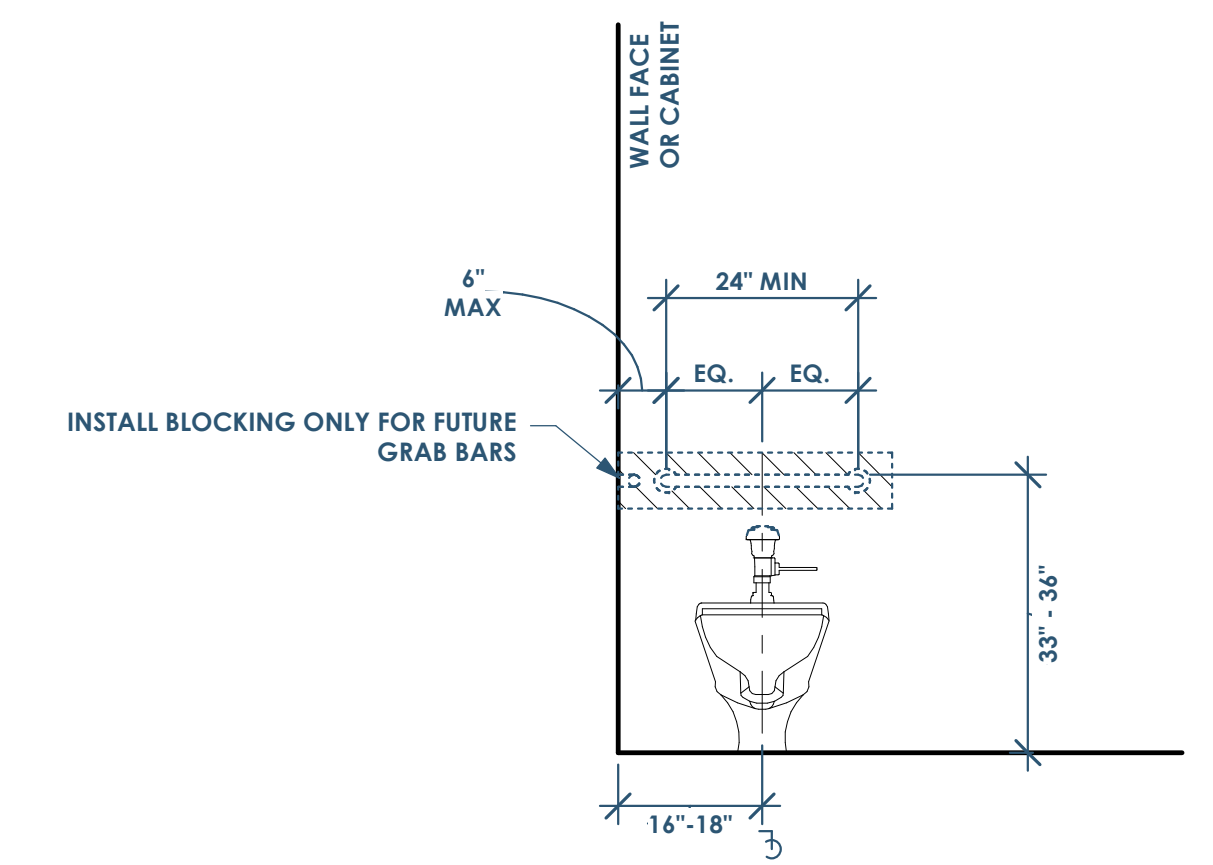

3B ADA - TYPE B - WATER CLOSET - FRONT  
1/2" = 1'-0"

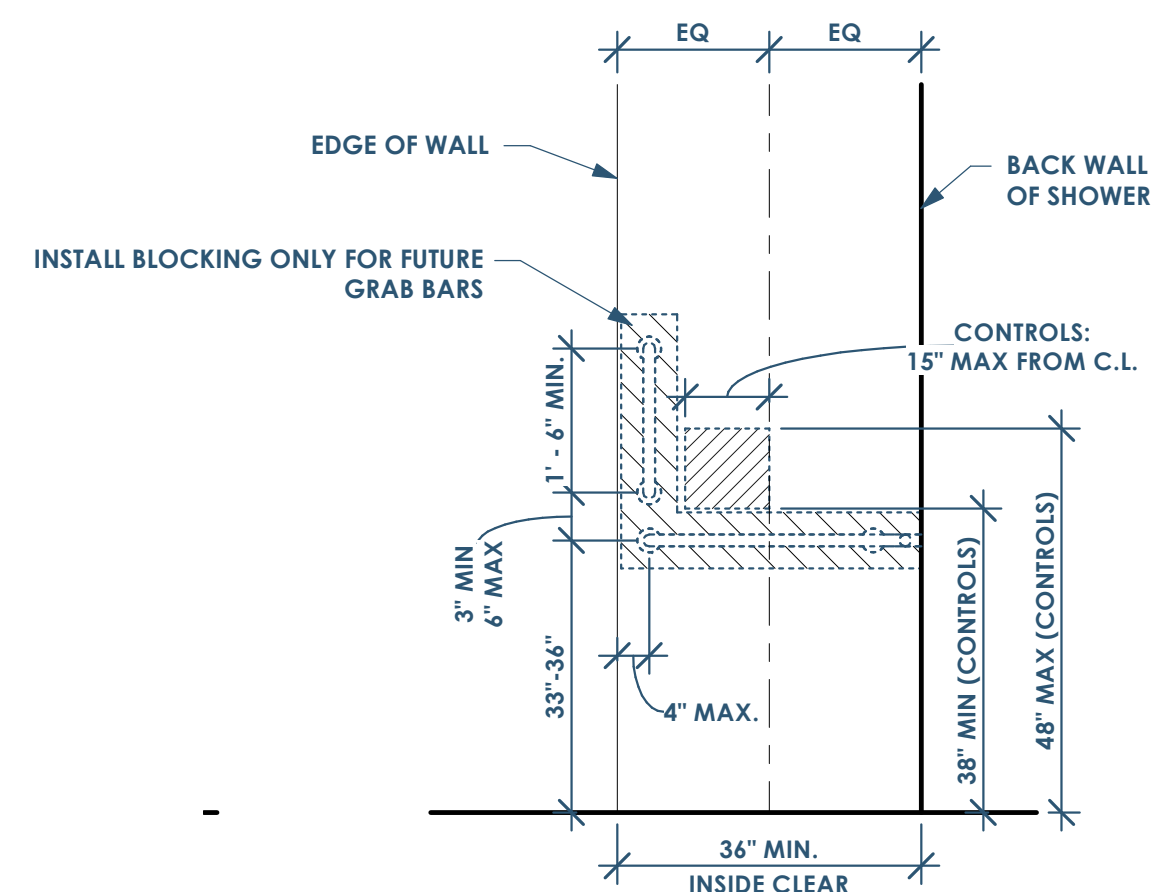

5A ADA - TYPE A & B - SHOWER - SIDE  
1/2" = 1'-0"

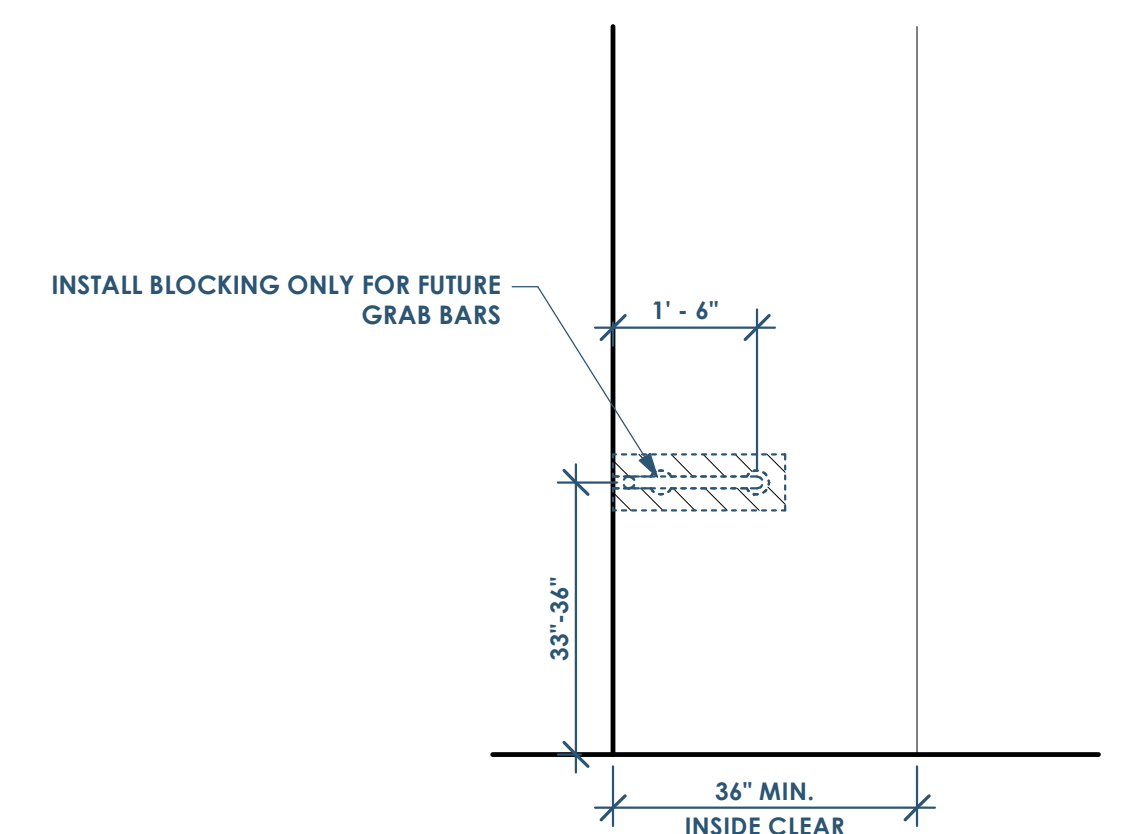

4A ADA - TYPE A & B - SHOWER - BACK  
1/2" = 1'-0"

GENERAL NOTES:  
• NOTE: PER IBC1210.2.2 WALLS AND PARTITIONS WITHIN 2 FEET (610MM) OF SERVICE SINKS, URINALS AND WATER CLOSETS SHALL HAVE A SMOOTH, HARD, NONABSORBENT SURFACE TO A HEIGHT OF NOT LESS THAN 4 FEET (1219 MM) ABOVE THE FLOOR, AND EXCEPT FOR STRUCTURAL ELEMENTS, THE MATERIAL USED IN SUCH WALLS SHALL BE OF A TYPE THAT IS NOT ADVERSELY AFFECTED BY MOISTURE  
• THESE ADA CLEARANCES AND GRAB BAR BLOCKING ARE ONLY REQUIRED FOR THE 1ST FLOOR UNIT

This project, like most OpeningDesign's projects, is open source (Attribution-ShareAlike 4.0 International-CC BY-SA 4.0)-freely available to any party for future use, assuming the terms such as Attribution and ShareAlike are honored.

Date	Description
05.19.2022	Progress Set

**openingdesign**

Architect: OpeningDesign  
17 S Fairchild | FL 7  
Madison, WI 53703  
ryan@openingdesign.com | 773.425.6456



Owner: Renovation Wranglers  
102 E 26th St  
Bryan, TX 77803  
Katherine@time.com | 979.450.9969

ARCHITECTURE  
Architect of Record: LKB Architecture  
2929 Allen Pkwy Suite 200  
Houston, TX 77019  
isa@lkbarchitecture.com | 713.425.3076

**DUDDLEY**  
Structural: Dudley  
6102 Imperial Loop Drive  
College Station, TX 77845  
(979) 777-0720

**amc**  
MEP: AMC Engineers  
508 E Jackson St # 552  
Burnet, TX 78611  
info@amcengineers.com

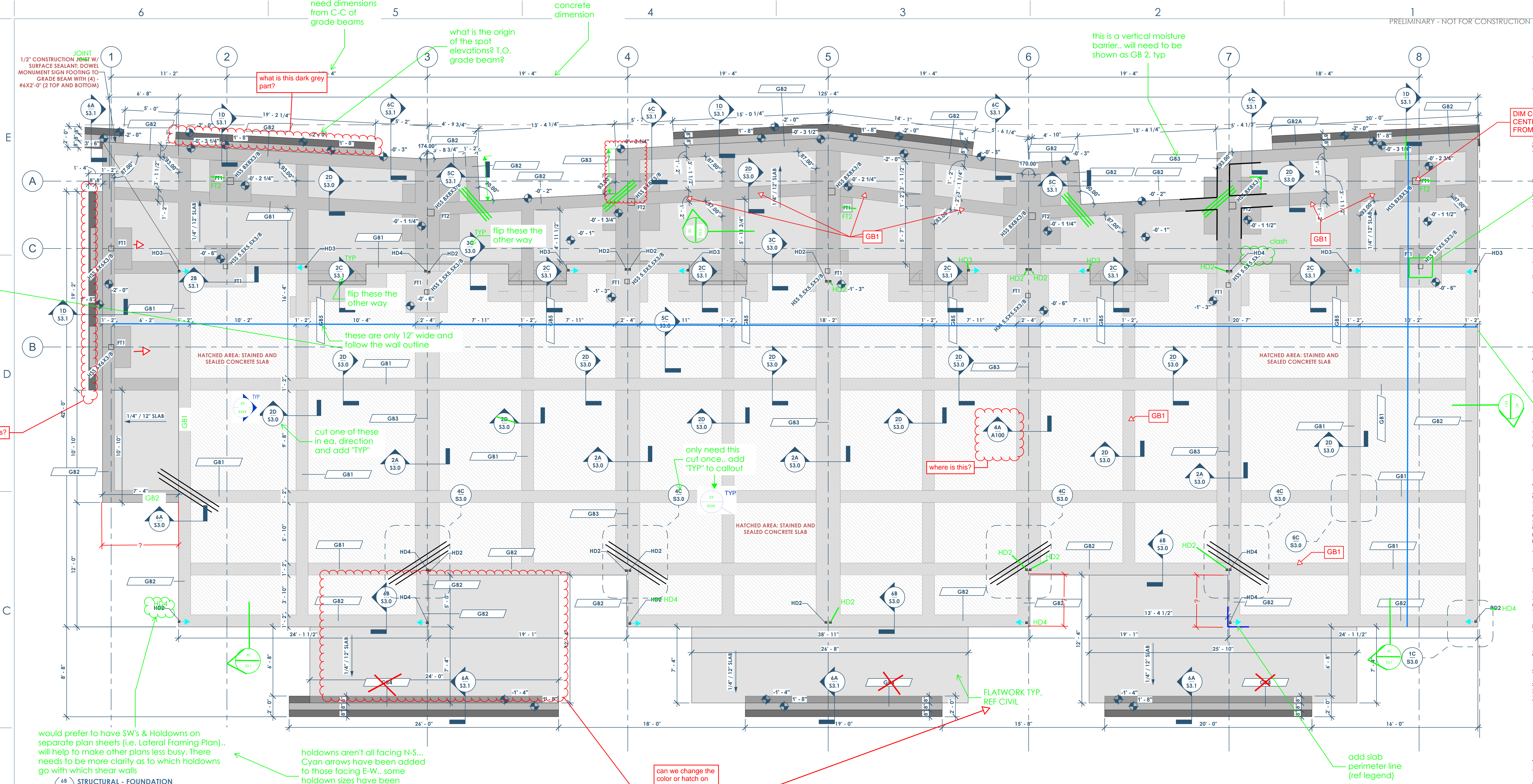

STRUCTURAL - FOUNDATION  
1/4" = 1'-0"

CAST-IN-PLACE

SHEARWALL HOLDDOWN AT FOUNDATION						
TYPE MARK	TYPE	HARDWARE	END POST	ATTACHMENT TO END POST	ANCHORAGE TO FOUNDATION	CAPACITY
HD2	POST-INSTALLED HOLDDOWN	SIMPSON HIT8	(2)-2X	(24) 0.148 X 3 NAILS	5/8" DIA. GR.36 ALL-THREAD WITH 8" EMBEDMENT WITH NUT AND WASHER	SEE SHEET 54.3 FOR DETAILS 4670
HD2	POST-INSTALLED HOLDDOWN	SIMPSON HIT14	(2)-2X	(30) 0.148 X 3 NAILS	ANCHOR CAST-INTO FOUNDATION	4610
HD3	POST-INSTALLED HOLDDOWN	SIMPSON HDU8-SDS2.5	(3)-2X	(20) 1/4" X 2 1/2" SDS SCREWS	7/8" DIA. GR.36 ALL-THREAD WITH 17 1/2" EMBEDMENT WITH NUT AND WASHER	SEE SHEET 54.3 FOR DETAILS 6200
HD4	POST-INSTALLED HOLDDOWN	SIMPSON HDU14-SDS2.5	6X6	(36) 1/4" X 2 1/2" SDS SCREWS	1" DIA. GR.36 ANCHOR ROD WITH 18" EMBEDMENT	SEE SHEET 54.3 FOR DETAILS 10000

STRUCTURAL CONNECTION NOTES:

- MINIMUM EDGE DISTANCE TO CENTERLINE OF BOLT IS 3". AT CORNERS, THE OPPOSING EDGE DISTANCE MUST BE ≥ 6".
- MINIMUM #4X36" LONG REINFORCING BAR LOCATED 3"-5" BELOW THE TOP OF THE SLAB IS REQUIRED TO BE CENTERED ON THE HOLDDOWN. AT CORNER, BEND THE BAR 90° AT THE CENTER.
- REFERENCE MECHANICALLY LAMINATED BUILT-UP COLUMN FOR NAILING REQUIREMENTS FOR END POST.
- SIMPSON ATR (REQUIRED Ø) WITH SIMPSON SET-3G IS AN ACCEPTABLE OPTION.

FOOTING SCHEDULE							
TYPE MARK	NAME	COUNT	DIMENSIONS			BOTTOM REINFORCING	TYPE COMMENTS
			WIDTH	LENGTH	DEPTH		
FT1	CONCRETE STEEL COLUMN FOOTING - 4' X 4' X 2'-6"	12	4'-0"	4'-0"	2'-6"	SEE DETAIL 28/S3.1	SEE DETAIL 28/S3.1
FT2	CONCRETE STEEL COLUMN FOOTING - 5.5' X 5.5' X 2.5'	4	5'-6"	5'-6"	2'-6"	SEE DETAIL 28/S3.1	SEE DETAIL 28/S3.1

PTI PARAMETERS	
E <sub>m</sub> - CENTER	4.8"
E <sub>m</sub> - EDGE	2.0"
Y <sub>m</sub> - CENTER	1.0"
Y <sub>m</sub> - EDGE	1.25"
EFFECTIVE PLASTICITY INDEX	35
ALLOW. BEARING (PSF)	1,800 PSF
MIN. BEAM EMBEDMENT BLOW FINAL GRADE	18"
MIN PERIMETER BEAM EMBEDMENT BELOW FINAL GRADE	52"

SLAB GEOMETRY	
AREA (SF)	5711 SF
PERIMETER (FT)	396 FT
SHAPE FACTOR (PERIMETER <sup>2</sup> /AREA)	27.5

FOUNDATION SCHEDULE							
BEAM ID	DESCRIPTION	WIDTH	DEPTH	TOP BARS	BOTTOM BARS	STIRRUPS	Type Comments
GB1	GRADE BEAM - INTERIOR - 14"	14"	30"	(3) - #6	(3) - #6	#3 @24" OC	IF
GB2	GRADE BEAM - PERIMETER - 14"	14"	30"	(3) - #6	(3) - #6	#3 @24" OC	IF
GB2A	GRADE BEAM - PERIMETER - 14" - W/ 8" CONCRETE WALL	14"	30"	(3) - #6	(3) - #6	#3 @24" OC	SEE ID/S3.1 FOR MORE DETAIL
GB3	GRADE BEAM - INTERIOR - 28"	28"	30"	DOUBLE GB1	DOUBLE GB1	DOUBLE GB1	(2) GB1 STIRRUP CAGES SIDE/SIDE - SEE DETAIL 2A/S3.0
GB4	0" CONCRETE FOUNDATION	0"	30"				SEE 6A/S3.1
GB5	TURNDOWN THICKENED SLAB	12"	12"	N/R	(2) - #4	N/R	1C/S3.1

FOUNDATION NOTES

FOUNDATION TYPE: BRAB TYPE III - STIFFENED NON-STRUCTURAL SLAB-ON-GROUND

SLAB THICKNESS: 5"

SLAB REINFORCEMENT: #4 @ 14" OC EACH WAY - REF DETAIL

DESIGN METHOD: ACI 318

VAPOR RETARDER: MINIMUM 15 MIL (UNLESS THICKER REQ'D BY ARCHITECT)

NOTES:

- BEAMS ARE TYPE B1 UNO.
- LOCATE THE FIRST STIRRUP A MAXIMUM OF 3" FROM FACE OF SUPPORT.
- BEAM DEPTH INDICATED IN THE SCHEDULE IS A STRUCTURAL MINIMUM THAT THE BEAM REINFORCEMENT CAGE MAY BE BASED UPON. REFERENCE GEOTECHNICAL REPORT FOR MINIMUM GRADE BEAM EMBEDMENT BELOW ADJACENT FINAL GRADE OR FLATWORK/PAVEMENT.
- N/R = NOT REQUIRED.

15 MIL - to match arch

PLAN NOTES

- VERIFY ALL EDGE OF FOUNDATION DIMENSIONS WITH FINAL ARCHITECTURE FLOOR PLANS.
- FORM DIMENSIONS SLAB DROPS, SLOPES, ETC. SHOWN AS AN AID TO CONTRACTOR ONLY. VERIFY EXACT DIMENSIONS AND LOCATIONS WITH ARCHITECT.
- DIMENSIONS ARE TO OF GRADE BEAMS OR EDGE OF SLAB UNLESS NOTED OTHERWISE.
- CONTROL JOINTS (SAW-CUTS) ARE RECOMMENDED TO REDUCE CRACKS IN THE SLAB, BUT ARE NOT REQUIRED FOR STRUCTURAL REQUIREMENTS. FOR THE RECOMMENDED MAXIMUM JOINT SPACING REFERENCE DETAIL.
- FOR FLATWORK OR PAVEMENT ABUTTING THE BUILDING FOUNDATION REFERENCE DETAIL.
- CONCRETE IS ASSUMED TO RECEIVE A STEEL TROWEL FINISH UNLESS NOTED OTHERWISE. NOTIFY ENGINEER IF ARCHITECTURALLY EXPOSED CONCRETE (STAINED, POLISHED, ETC.) IS PLANNED FOR ADDITIONAL SHRINKAGE CRACKING MITIGATION METHODS.

This project, like most OpeningDesign's projects, is open source (Attribution-ShareAlike 4.0 International-CC BY-SA 4.0)-freely available to any party for future use, assuming the terms such as Attribution and ShareAlike are honored.





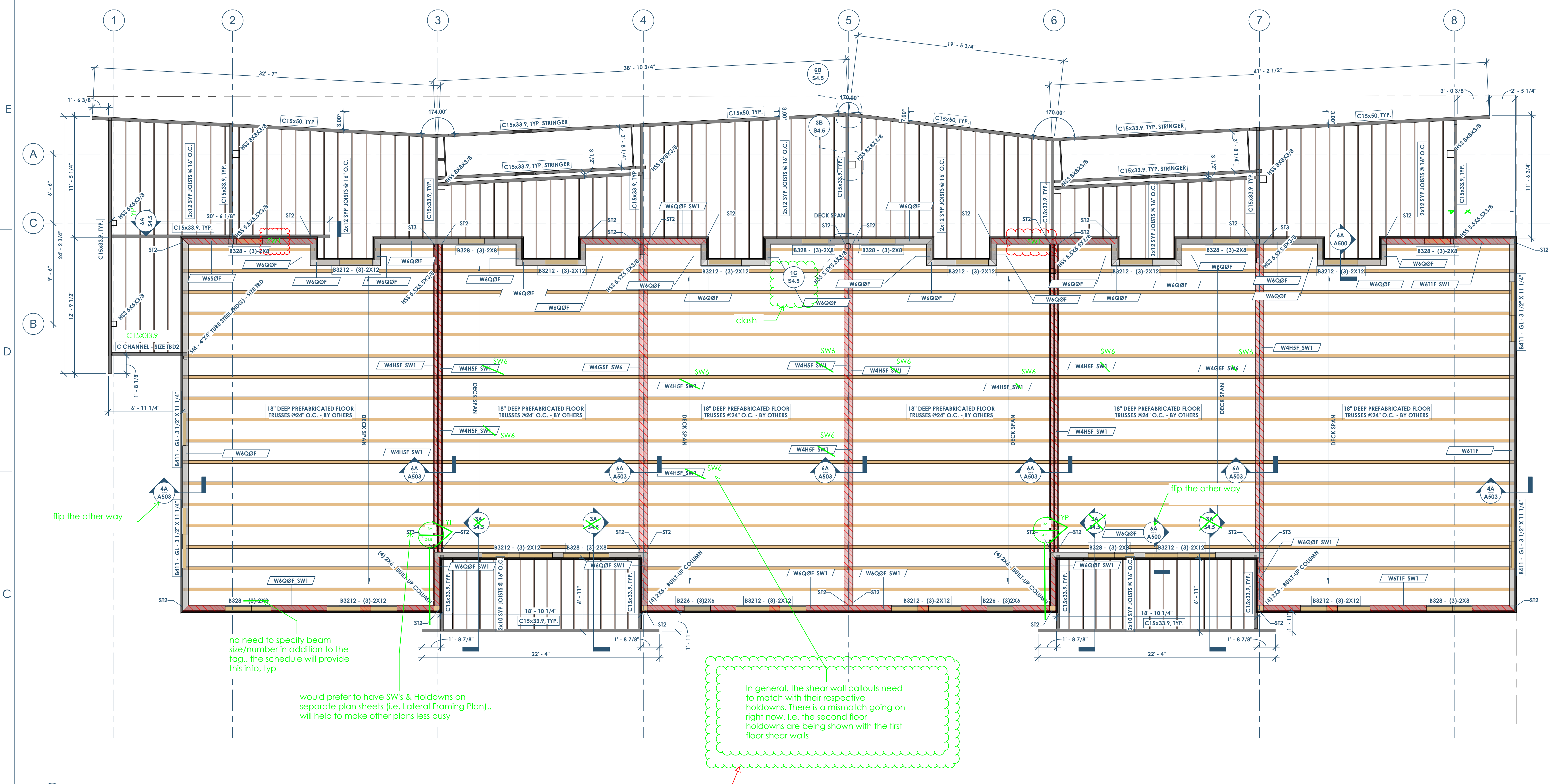

68  
S0.2 FRAMING PLAN - 2ND FLOOR  
1/4" = 1'-0"

SHEAR WALL SCHEDULE					
SHEAR WALL TYPE	SHEATHING TYPE	PANEL EDGE NAILING	FIELD NAILING	ANCHORAGE	ALLOWABLE WIND SHEAR CAPACITY
SW1	7/16" WSP	4"	12"	(5/8" Ø @ 40" O.C. - AT CONCRETE) - (0.131" X 3" LONG NAILS @ 3" OC - AT WOOD)	335 PLF
SW2	7/16" WSP	4"	12"	(5/8" Ø @ 32" O.C. - AT CONCRETE) - (0.131" X 3" LONG NAILS @ 3" OC - AT WOOD)	490 PLF
SW3	7/16" WSP	3"	12"	(5/8" Ø @ 24" O.C. - AT CONCRETE) - (0.131" X 3" LONG NAILS @ 2" OC - AT WOOD)	630 PLF
SW4	15/32" WSP	3"	12"	(5/8" Ø @ 24" O.C. - AT CONCRETE) - (0.148" X 3" LONG NAILS @ 2" OC - AT WOOD)	840 PLF
SW5	15/32" WSP	2"	12"	(5/8" Ø @ 24" O.C. - AT CONCRETE) - (0.148" X 3" LONG NAILS @ 2" OC - AT WOOD)	991 PLF
SW6	5/8" GYP WALLBOARD	4"	12"	(5/8" Ø @ 48" O.C. - AT CONCRETE) - (0.131" X 3" LONG NAILS @ 3" OC - AT WOOD)	115 PLF
SW7	5/8" GYP WALLBOARD	4"	12"	(5/8" Ø @ 48" O.C. - AT CONCRETE) - (0.131" X 3" LONG NAILS @ 3" OC - AT WOOD)	145 PLF

- SHEAR WALL NOTES:**
- ALL FASTENERS FOR WOOD STRUCTURAL PANEL SHALL BE FLAT HEAD NAILS CONSISTING OF THE FOLLOWING UNO:
    - A. 0.131" Ø X 2 1/2" LONG
    - B. 0.148" Ø X 3" LONG
  - FASTENERS FOR GYPSUM WALLBOARD SHALL BE ONE OF THE FOLLOWING:
    - A. 6d COOLER NAILS (0.092" X 1 7/8" LONG, 1/4" HEAD)
    - B. WALLBOARD NAIL (0.0912" X 1 7/8" LONG, 1/4" HEAD)
    - C. 0.120" NAIL X 1-3/4" LONG, MIN 3/8" HEAD
    - D. NO. 6 TYPE S OR W DRYWALL SCREWS 1-1/4" LONG
  - ANCHORS INTO CONCRETE SHALL EITHER BE CAST-IN-PLACE J-BOLTS OR ADHESIVE ANCHORS WITH A MINIMUM EMBEDMENT OF 8". THE CONTRACTOR SHALL SUBMIT PROPOSED ADHESIVE ANCHOR ASSEMBLY FOR APPROVAL.
  - ALL PANEL EDGES SHALL BE BLOCKED.
  - WSP = WOOD STRUCTURAL PANEL. REF GENERAL NOTES FOR SPECIFICATIONS.
  - IF WALL IS SHEATHED ON BOTH SIDES, THEN SILL PLATE ANCHORAGE AND CONNECTION OF BOTTOM PLATE TO TOP PLATE SHALL BE DOUBLED.
  - PANELS MUST BE INSTALLED DIRECTLY TO FRAMING.
  - VALUES CALCULATED ARE FOR SOUTHERN PINE OR DOUGLASS FIR LARCH FRAMING. CONTACT OTHER SPECIES ARE USED.
  - PROVIDE 1/8" WIDE JOINTS IN SHEATHING TO ALLOW FOR SHRINKAGE AND EXPANSION OF THE PANELS.
  - SHEAR WALLS REFERENCED ARE FOR SHEAR WALLS BELOW FLOOR**

SHEARWALL HOLD-DOWNS AT ELEVATED FLOOR					
TYPE MARK	HOLD-DOWN HARDWARE	END LENGTH (IN)	FASTENERS	END POST	ALLOWABLE TENSION LOAD (LBF)
ST1	(1) SIMPSON CS18	12"	(11) 0.131 X 2 1/2" NAILS	(2) - 2X	1,370
ST2	(2) SIMPSON CS18	12"	(11) 0.131 X 2 1/2" NAILS	(2) - 2X	2,740
ST3	(2) SIMPSON CS14	19"	(18) 0.131 X 2 1/2" NAILS	(3) - 2X	4,780

- SHEARWALL & HOLD-DOWN NOTES:**
- MULTIPLE FILES OF END POST SHALL BE FASTENED TOGETHER PER THE MECHANICALLY BUILT-UP COLUMN NAILED DETAIL.
  - REFERENCE DETAIL 6A/S4.2 FOR TYPICAL HOLD-DOWN CONFIGURATIONS.
  - HOLD-DOWNS REFERENCED ARE FOR SHEAR WALLS ABOVE FLOOR**

BEAM SCHEDULE					
BEAM TAG	BEAM SIZE	STUD PACK - NUMBER OF STUDS	FACE-MOUNT HANGER	TOP-FLANGE HANGER	NOTE NUMBER
B24H	(3)2X6	2	LUS26-2	HU26-2TF	1,2,3,4,6,7,8,9
B328H	(3)-2X8	2	LUS26-3	HUS48TF	1,2,3,4,6,7,8,9
B3212H	(3)-2X12	3	HU210-3	HU212-3TF	1,2,3,4,6,7,8,9
B411	GL - 3 1/2" X 11 1/4"	3	HU5410	HB3.56/11.25	3,4,5,6,7,8,9

- BEAM LEGEND NOTES:**
- MULTIPLE PLY DIMENSIONAL LUMBER BEAMS SHALL RECEIVE 1/2" PLYWOOD SHEATHING. SEE TYPICAL DETAIL.
  - FOR NAILING BUILT-UP BEAMS REFER TO DETAIL 2A/S4.0
  - FOR KING AND JACK STUD REQUIREMENTS FOR EXTERIOR HEADERS REFER TO DETAIL 4C/S4.1
  - FOR KING AND JACK STUD REQUIREMENTS IN INTERIOR HEADERS REFER TO DETAIL 5B/S4.1
  - BEAMS SHALL BE ANTHONY POWER BEAM GLUE LAMINATED BEAMS OR APPROVED EQUAL.
  - STUD PACKS ARE REQUIRED WHEN BEAM IS BEARING ON A WALL ASSEMBLY. STUD PACKS MUST CONTINUE ALL THE WAY TO THE FOUNDATION UNLESS TRANSFERRED BY A BEAM.
  - ALL STUDS IN STUD PACK SHALL BE NO.2 SOUTHERN PINE OR BETTER.
  - SHEATHING AND/OR DRYWALL MUST BE ATTACHED TO EACH INDIVIDUAL STUD IN THE STUD PACK.
  - ALL STUDS IN STUD PACK MUST BE FASTENED PER MECHANICALLY LAMINATED BUILT-UP COLUMN-NAILED - REFER TO 6A/S4.1
  - ALL STUDS IN STUD PACK MUST BE FASTENED PER MECHANICALLY LAMINATED BUILT-UP COLUMN-NAILED - REFER TO 6A/S4.1

WALL STUD SCHEDULE				
TOP OF WALL	MAX PLATE HT	EXTERIOR WALL	INTERIOR NON-LOAD BEARING	PARTY WALL
ROOF	8" - 11 5/8"	2X4 NO.2 @ 16" O.C.	2X4 STUD @ 16" O.C.	2X4 STUD @ 16" O.C.
3RD	10" - 8"	2X4 NO.2 @ 16" O.C.	2X4 STUD @ 16" O.C.	2X4 STUD @ 12" O.C.
2ND	10" - 9 5/8"	2X4 NO.2 @ 16" O.C.	2X4 STUD @ 16" O.C.	2X4 STUD @ 8" O.C.

the tags need to differentiate between "B" and "H" on plan. The "H" headers will be built-up SYP No. 2, and the B411 will be an anthony power beam

- BEAM LEGEND NOTES:**
- "H" INDICATES FOR USE IN HEADERS, MULTIPLE PLY DIMENSIONAL LUMBER BEAMS SHALL RECEIVE 1/2" PLYWOOD SHEATHING. SEE TYPICAL DETAIL.
  - ALL "B" BEAMS SHALL BE ANTHONY POWER BEAM GLUE LAMINATED BEAMS OR APPROVED EQUAL.
  - STUD PACKS ARE REQUIRED WHEN BEAM IS BEARING ON A WALL ASSEMBLY. STUD PACKS MUST CONTINUE ALL THE WAY TO THE FOUNDATION UNLESS TRANSFERRED BY A BEAM.
  - ALL STUDS IN STUD PACK SHALL BE NO.2 SOUTHERN PINE OR BETTER.
  - SHEATHING AND/OR DRYWALL MUST BE ATTACHED TO EACH INDIVIDUAL STUD IN THE STUD PACK.
  - ALL STUDS IN STUD PACK MUST BE FASTENED PER MECHANICALLY LAMINATED BUILT-UP COLUMN-NAILED.
  - HANGER SPECIFIED ARE THE MINIMUM REQUIRED UNO ON PLAN.

either put sw and corresponding holdowns on the same plan or add these notes

This project, like most OpeningDesign's projects, is open source (Attribution-ShareAlike 4.0 International-CC BY-SA 4.0)-freely available to any party for future use, assuming the terms such as Attribution and ShareAlike are honored.

**RENOVATION**  
Wranglers  
Owner: Renovation Wranglers  
102 E 26th St  
Bryan, TX 77803  
katheneason@re.com | 979.450.9969

**ARCHITECTURE**  
Architect of Record: LKB Architecture  
2929 Allen Pkwy Suite 200  
Houston, TX 77019  
isa@lkbarchitecture.com | 713.425.3076

**MEP**  
MEP: AMC Engineers  
508 E Jackson St # 552  
Burnet, TX 78611  
info@amcengineers.com

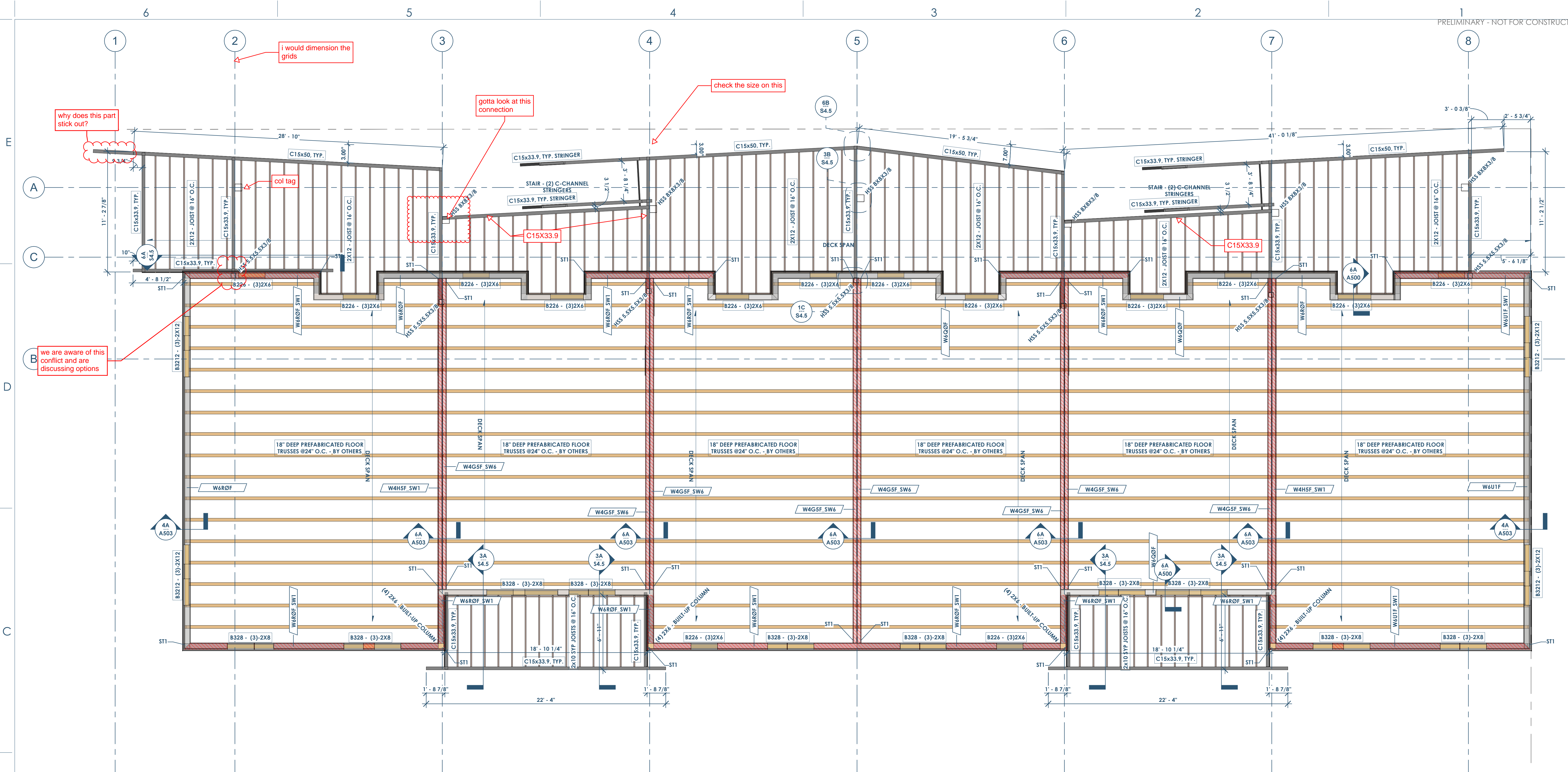

4B  
S0.3  
FRAMING PLAN - 3RD FLOOR  
1/4" = 1'-0"

SHEAR WALL SCHEDULE					
SHEAR WALL TYPE	SHEATHING TYPE	PANEL EDGE NAILING	FIELD NAILING	ANCHORAGE	ALLOWABLE WIND SHEAR CAPACITY
SW1	7/16" WSP	4"	12"	(5/8" Ø @ 32" O.C. - AT CONCRETE) - (0.131" X 3" LONG NAILS @ 3" OC - AT WOOD)	335 PLF
SW2	7/16" WSP	4"	12"	(5/8" Ø @ 32" O.C. - AT CONCRETE) - (0.131" X 3" LONG NAILS @ 3" OC - AT WOOD)	490 PLF
SW3	7/16" WSP	3"	12"	(5/8" Ø @ 24" O.C. - AT CONCRETE) - (0.131" X 3" LONG NAILS @ 2" OC - AT WOOD)	630 PLF
SW4	15/32" WSP	3"	12"	(5/8" Ø @ 24" O.C. - AT CONCRETE) - (0.148" X 3" LONG NAILS @ 2" OC - AT WOOD)	840 PLF
SW5	15/32" WSP	2"	12"	(5/8" Ø @ 24" O.C. - AT CONCRETE) - (0.148" X 3" LONG NAILS @ 2" OC - AT WOOD)	991 PLF
SW6	5/8" GYP WALLBOARD	7"	12"	(5/8" Ø @ 48" O.C. - AT CONCRETE) - (0.131" X 3" LONG NAILS @ 3" OC - AT WOOD)	115 PLF
SW7	5/8" GYP WALLBOARD	4"	12"	(5/8" Ø @ 48" O.C. - AT CONCRETE) - (0.131" X 3" LONG NAILS @ 3" OC - AT WOOD)	145 PLF

- SHEAR WALL NOTES:**
- ALL FASTENERS FOR WOOD STRUCTURAL PANEL SHALL BE FLAT HEAD NAILS CONSISTING OF THE FOLLOWING UNO:
    - A. 0.131" Ø X 2 1/2" LONG
    - B. 0.148" Ø X 3" LONG
  - FASTENERS FOR GYPSUM WALLBOARD SHALL BE ONE OF THE FOLLOWING:
    - A. 6d COOLER NAILS (0.092" X 1 7/8" LONG, 1/4" HEAD)
    - B. WALLBOARD NAIL (0.0912" X 1 7/8" LONG, 1/4" HEAD)
    - C. 0.120" NAIL X 1-3/4" LONG, MIN 3/8" HEAD
    - D. NO. 6 TYPE S OR W DRYWALL SCREWS 1-1/4" LONG
  - ANCHORS INTO CONCRETE SHALL EITHER BE CAST-IN-PLACE J-BOLTS OR ADHESIVE ANCHORS WITH A MINIMUM EMBEDMENT OF 8". THE CONTRACTOR SHALL SUBMIT PROPOSED ADHESIVE ANCHOR ASSEMBLY FOR APPROVAL.
  - ALL PANEL EDGES SHALL BE BLOCKED.
  - WSP = WOOD STRUCTURAL PANEL. REF GENERAL NOTES FOR SPECIFICATIONS.
  - IF WALL IS SHEATHED ON BOTH SIDES, THEN SILL PLATE ANCHORAGE AND CONNECTION OF BOTTOM PLATE TO TOP PLATE SHALL BE DOUBLED.
  - PANELS MUST BE INSTALLED DIRECTLY TO FRAMING.
  - VALUES CALCULATED ARE FOR SOUTHERN PINE OR DOUGLAS-FIR LARCH FRAMING. CONTACT FOR IF OTHER SPECIES ARE USED.
  - PROVIDE 1/8" WIDE JOINTS IN SHEATHING TO ALLOW FOR SHRINKAGE AND EXPANSION OF THE PANELS.

SHEARWALL HOLD-DOWNS AT ELEVATED FLOOR					
TYPE MARK	HOLD-DOWN HARDWARE	END LENGTH (IN)	FASTENERS	END POST	ALLOWABLE TENSION LOAD (LBF)
ST1	(1) SIMPSON CS18	12"	((11) 0.131 X 2 1/2" NAILS	(2) - 2X	1,370
ST2	(2) SIMPSON CS18	12"	((11) 0.131 X 2 1/2" NAILS	(2) - 2X	2740
ST3	(2) SIMPSON CS14	19"	((18) 0.131 X 2 1/2" NAILS	(3) - 2X	4980

- SHEARWALL & HOLD-DOWN NOTES:**
- MULTIPLE PLIES OF END POSTS SHALL BE FASTENED TOGETHER PER THE MECHANICALLY BUILT-UP COLUMN NAILED DETAIL.
  - REFERENCE DETAIL 6A/S4.2 FOR TYPICAL HOLD-DOWN CONFIGURATIONS.

ref comments on previous page

FLOOR-TO-FLOOR SCREW SCHEDULE	
12" < TRUSS DEPTH ≤ 14"	SIMPSON SDWF2720-TUW
14" < TRUSS DEPTH ≤ 18"	SIMPSON SDWF2726-TUW
18" < TRUSS DEPTH ≤ 24"	SIMPSON SDWF2730-TUW

BEAM SCHEDULE					
BEAM TAG	BEAM SIZE	STUD PACK - NUMBER OF STUDS	FACE-MOUNT HANGER	TOP-FLANGE HANGER	NOTE NUMBER
B226	(3)2X6	2	LUS26-2	HU26-2TF	1,2,3,4,6,7,8,9
B328	(3)-2X8	2	LUS26-3	HUS48TF	1,2,3,4,6,7,8,9
B3212	(3)-2X12	3	HU210-3	HU212-3TF	1,2,3,4,6,7,8,9
B411	GL - 3 1/2" X 1 1/4"	3	HUS410	HB3.56/11.25	3,4,5,6,7,8,9

- BEAM LEGEND NOTES:**
- MULTIPLE PLY DIMENSIONAL LUMBER BEAMS SHALL RECEIVE 1/2" PLYWOOD SHEATHING. SEE TYPICAL DETAIL.
  - FOR NAILING BUILT-UP BEAMS REFER TO DETAIL 2A/S4.0
  - FOR KING AND JACK STUD REQUIREMENTS FOR EXTERIOR HEADERS REFER TO DETAIL 4C/S4.1
  - FOR KING AND JACK STUD REQUIREMENTS IN INTERIOR HEADERS REFER TO DETAIL 5B/S4.1
  - BEAMS SHALL BE ANTHONY POWER BEAM GLUE LAMINATED BEAMS OR APPROVED EQUAL
  - STUD PACKS ARE REQUIRED WHEN BEAM IS BEARING ON A WALL ASSEMBLY. STUD PACKS MUST CONTINUE ALL THE WAY TO THE FOUNDATION UNLESS TRANSFERRED BY A BEAM.
  - ALL STUDS IN STUD PACK SHALL BE NO. 2 SOUTHERN PINE OR BETTER.
  - SHEATHING AND/OR DRYWALL MUST BE ATTACHED TO EACH INDIVIDUAL STUD IN THE STUD PACK.
  - ALL STUDS IN STUD PACK MUST BE FASTENED PER MECHANICALLY LAMINATED BUILT-UP COLUMN-NAILED - REFER TO 6A/S4.1

WALL STUD SCHEDULE				
TOP OF WALL	MAX PLATE HT	EXTERIOR WALL	INTERIOR NON-LOAD BEARING	PARTY WALL
ROOF	8" - 11 5/8"	2X4 NO.2 @ 16" O.C.	2X4 STUD @ 16" O.C.	2X4 STUD @ 16" O.C.
3RD	10" - 8"	2X4 NO.2 @ 16" O.C.	2X4 STUD @ 16" O.C.	2X4 STUD @ 12" O.C.
2ND	10" - 9/8"	2X4 NO.2 @ 16" O.C.	2X4 STUD @ 16" O.C.	2X4 STUD @ 8" O.C.

This project, like most OpeningDesign's projects, is open source (Attribution-ShareAlike, 4.0 International-CC, BY-SA 4.0) - freely available to any party for future use, assuming the terms such as Attribution and ShareAlike are honored.

**openingdesign**  
Architect: OpeningDesign  
17 S Fairchild | FL 7  
Madison, WI 53703  
ryan@openingdesign.com | 773.425.6456

Date:	Description:
05.19.2022	Progress Set

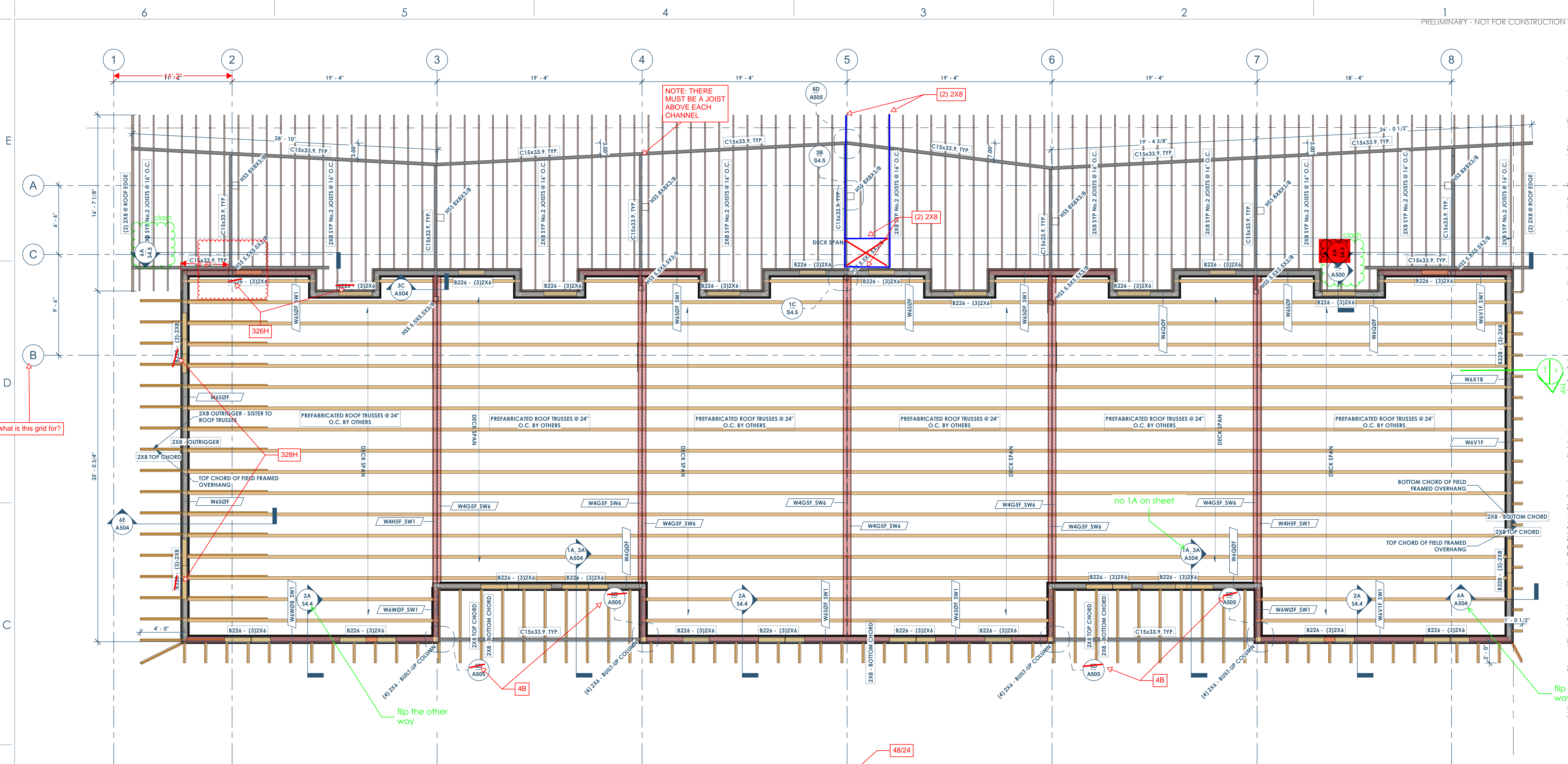

what is this grid for?

flip the other way

no 1A on sheet

68  
S0.4 FRAMING PLAN - ROOF  
1/4" = 1'-0"

SHEAR WALL SCHEDULE					
SHEAR WALL TYPE	SHEATHING TYPE	PANEL EDGE NAILING	FIELD NAILING	ANCHORAGE	ALLOWABLE WIND SHEAR CAPACITY
SW1	7/16" WSP	6"	12"	(5/8" Ø @ 40" O.C. - AT CONCRETE) - (0.131" X 3" LONG NAILS @ 3" OC - AT WOOD)	335 PLF
SW2	7/16" WSP	4"	12"	(5/8" Ø @ 32" O.C. - AT CONCRETE) - (0.131" X 3" LONG NAILS @ 3" OC - AT WOOD)	490 PLF
SW3	7/16" WSP	3"	12"	(5/8" Ø @ 24" O.C. - AT CONCRETE) - (0.131" X 3" LONG NAILS @ 2" OC - AT WOOD)	630 PLF
SW4	15/32" WSP	3"	12"	(5/8" Ø @ 24" O.C. - AT CONCRETE) - (0.148" X 3" LONG NAILS @ 2" OC - AT WOOD)	840 PLF
SW5	15/32" WSP	2"	12"	(5/8" Ø @ 24" O.C. - AT CONCRETE) - (0.148" X 3" LONG NAILS @ 2" OC - AT WOOD)	991 PLF
SW6	5/8" GYP WALLBOARD	7"	12"	(5/8" Ø @ 48" O.C. - AT CONCRETE) - (0.131" X 3" LONG NAILS @ 3" OC - AT WOOD)	115 PLF
SW7	5/8" GYP WALLBOARD	4"	12"	(5/8" Ø @ 48" O.C. - AT CONCRETE) - (0.131" X 3" LONG NAILS @ 3" OC - AT WOOD)	145 PLF

- SHEAR WALL NOTES:**
- ALL FASTENERS FOR WOOD STRUCTURAL PANEL SHALL BE FLAT HEAD NAILS CONSISTING OF THE FOLLOWING UNO:
    - A. 0.131" Ø X 2 1/2" LONG
    - B. 0.148" Ø X 3" LONG
  - FASTENERS FOR GYPSUM WALLBOARD SHALL BE ONE OF THE FOLLOWING:
    - A. 6d COOLER NAILS (0.092" X 1 7/8" LONG, 1/4" HEAD)
    - B. WALLBOARD NAIL (0.0915" X 1 7/8" LONG, 19/64" HEAD)
    - C. 0.130" NAIL X 1-3/4" LONG, MIN 3/8" HEAD
    - D. NO. 6 TYPE S OR W DRYWALL SCREWS 1-1/4" LONG
  - ANCHORS INTO CONCRETE SHALL EITHER BE CAST-IN-PLACE J-BOLTS OR ADHESIVE ANCHORS WITH A MINIMUM EMBEDMENT OF 8". THE CONTRACTOR SHALL SUBMIT PROPOSED ADHESIVE ANCHOR ASSEMBLY FOR APPROVAL.
  - ALL PANEL EDGES SHALL BE BLOCKED.
  - WSP = WOOD STRUCTURAL PANEL. REF GENERAL NOTES FOR SPECIFICATIONS.
  - IF WALL IS SHEATHED ON BOTH SIDES, THEN SILL PLATE ANCHORAGE AND CONNECTION OF BOTTOM PLATE TO TOP PLATE SHALL BE DOUBLED.
  - PANELS MUST BE INSTALLED DIRECTLY TO FRAMING.
  - VALUES CALCULATED ARE FOR SOUTHERN PINE OR DOUGLAS-FIR LARCH FRAMING. CONTACT EOR IF OTHER SPECIES ARE USED.
  - PROVIDE 1/8" WIDE JOINTS IN SHEATHING TO ALLOW FOR SHRINKAGE AND EXPANSION OF THE PANELS.

- ROOF FRAMING NOTES:**
- METAL PLATE CONNECTED ROOF TRUSS FRAMING:**
- METAL PLATE CONNECTED WOOD TRUSSES SHALL BE SPACED @ 24" O.C. UNLESS NOTED OTHERWISE. LOADING CRITERIA SHALL BE AS FOLLOWS:
    - A. TOP CHORD LIVE LOAD (TCLL): 20 PSF
    - B. REF MECHANICAL DRAWINGS FOR RTUS.
    - C. TOP CHORD DEAD LOAD (TCDL): 5 PSF - SINGLE-PLY MEMBRANE ROOF (NOT INCLUDING SELF-WEIGHT)
    - D. BOTTOM CHORD LIVE LOAD (BCLL): 10 PSF (NON-CONCURRENT WITH TCLL)
    - E. BOTTOM CHORD DEAD LOAD (BCDL): 5 PSF
  - TOP CHORD WIND LOAD: REF COMPONENTS AND CLADDING SCHEDULE
  - TRUSS DEFLECTION LIMITS: TRUSSES SHALL BE LIMITED TO THE FOLLOWING DEFLECTION LIMITS:
    - A. PITCHED ROOF TRUSSES: LIVE LOAD (L/240) TOTAL LOAD (L/180)
    - B. SHALLOW (< 4:12) PITCHED ROOF TRUSSES: LIVE LOAD (L/240) TOTAL LOAD (L/240)
    - C. PITCHED ROOF TRUSSES: 1.00 X DEFLECTION FROM ACTUAL DEAD LOAD.
  - DRAG TRUSSES SHALL BE PROVIDED DIRECTLY OVER INTERIOR SHEAR WALLS AND SHALL BE DESIGNED FOR A TOTAL FORCE EQUAL TO THE LENGTH OF THE SHEAR WALL MULTIPLIED BY THE ALLOWABLE SHEAR VALUE PROVIDED IN THE SHEAR WALL SCHEDULE FOR THAT SHEAR WALL TYPE.
  - TRUSS RESTRAINT/BRACING METHODS SHALL BE IN ACCORDANCE WITH BC31-B3 UNLESS NOTED OTHERWISE.

- ROOF DECKING NOTES:**
- ROOF DECKING SHALL BE 3/4" APA RATED SHEATHING (SPAN RATING S3110).
  - PANELS SHALL SPAN 3 MORE RAFTERS IN THE LONG DIMENSION.
  - PANEL CLIPS:
    - A. SINGLE-PLY OR MODIFIED BITUMEN ROOFING SYSTEMS:
      - a. LOW SLOPE ROOF (LESS THAN OR EQUAL TO 2:12)
        - DECKING SHALL HAVE PANEL EDGE CLIPS (H-CLIPS) LOCATED MIDWAY BETWEEN EACH SUPPORT.
      - b. SLOPE GREATER THAN 2:12
        - DECKING SHALL HAVE PANEL EDGE CLIPS (H-CLIPS) LOCATED MIDWAY BETWEEN EACH SUPPORT FOR ANY SPAN GREATER THAN 12' O.C.
    - ANY OTHER TYPE OF ROOFING SYSTEM
      - DECKING SHALL HAVE PANEL EDGE CLIPS (H-CLIPS) LOCATED MIDWAY BETWEEN EACH SUPPORT.

ROOF DECKING FASTENING		
ZONE	PANE EDGE / BOUNDARY	FIELD
ZONE 1	@ 6" O.C. MAX	@ 12" O.C. MAX
ZONE 2	@ 6" O.C. MAX	@ 6" O.C. MAX
ZONE 3	@ 4" O.C. MAX	@ 6" O.C. MAX
ZONE 3 OVERHANG	@ 3" O.C. MAX	@ 6" O.C. MAX

- ROOF DECKING FASTENING NOTES:**
- ALL NAILS SHALL BE 0.131" Ø X 2 1/2" RING SHANK NAILS
  - REFERENCE THE COMPONENTS AND CLADDING WIND PRESSURE MAP ON THE
  - GENERAL NOTES FOR ZONE LOCATIONS.
  - EDGE SPACING ALSO APPLIES OVER THE TOP OF SHEARWALLS.

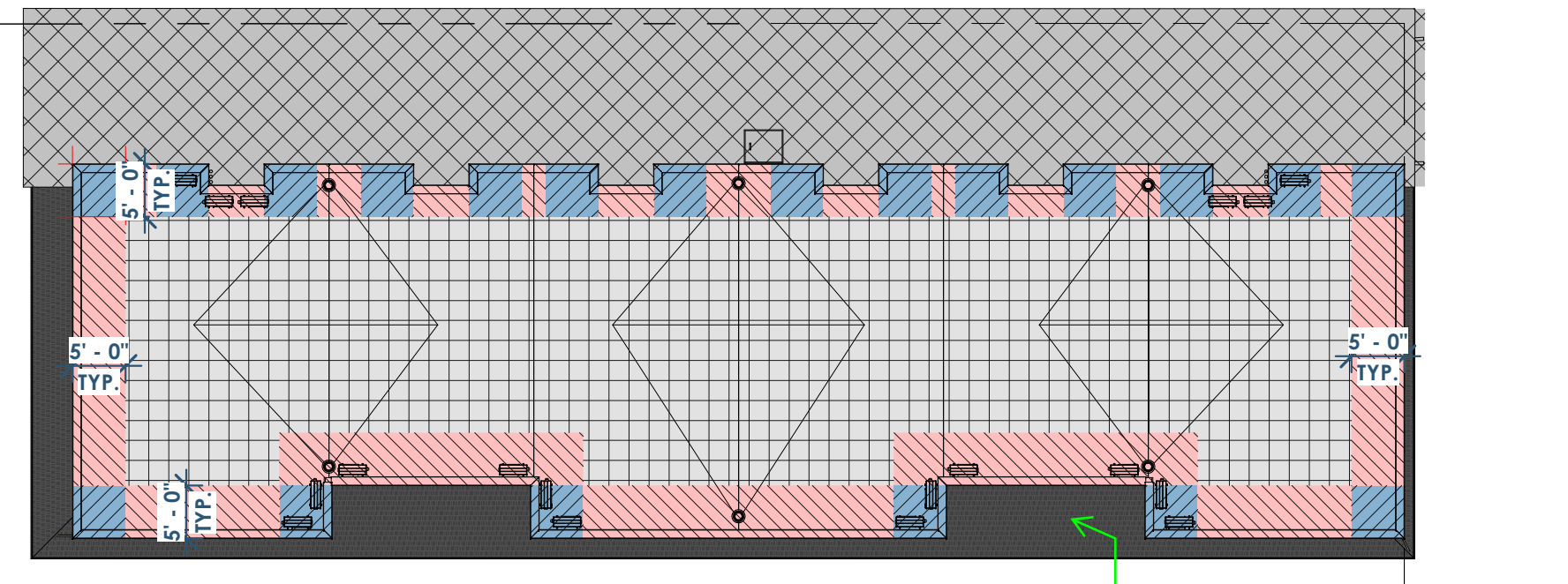

6A  
S0.4 FLOOR PLAN - ROOF WIND ZONE  
1/16" = 1'-0"

BEAM SCHEDULE					
BEAM TAG	BEAM SIZE	STUD PACK - NUMBER OF STUDS	FACE-MOUNT HANGER	TOP-FLANGE HANGER	NOTE NUMBER
B226	(3)2X6	2	LUS26-2	HU26-2TF	1,2,3,4,6,7,8,9
B328	(3)2X8	2	LUS26-3	HU548TF	1,2,3,4,6,7,8,9
B3212	(3)2X12	3	HU210-3	HU212-3TF	1,2,3,4,6,7,8,9
B411	GL - 3 1/2" X 11 1/4"	3	HHU5410	H83.56/11.25	3,4,5,6,7,8,9

- BEAM LEGEND NOTES:**
- MULTIPLE PLY DIMENSIONAL LUMBER BEAMS SHALL RECEIVE 1/2" PLYWOOD SHEATHING. SEE TYPICAL DETAIL.
  - FOR NAILING BUILT-UP BEAMS REFER TO DETAIL 2A/S4.0
  - FOR KING AND JACK STUD REQUIREMENTS FOR EXTERIOR HEADERS REFER TO DETAIL 4C/S4.1
  - FOR KING AND JACK STUD REQUIREMENTS IN INTERIOR HEADERS REFER TO DETAIL 5B/S4.1
  - BEAMS SHALL BE ANTHONY POWER BEAM GLUE LAMINATED BEAMS OR APPROVED EQUAL.
  - STUD PACKS ARE REQUIRED WHEN BEAM IS BEARING ON A WALL ASSEMBLY. STUD PACKS MUST CONTINUE ALL THE WAY TO THE FOUNDATION UNLESS TRANSFERRED BY A BEAM.
  - ALL STUDS IN STUD PACK MUST BE NO. 2 SOUTHERN PINE OR BETTER.
  - SHEATHING AND/OR DRYWALL MUST BE ATTACHED TO EACH INDIVIDUAL STUD IN THE STUD PACK.
  - ALL STUDS IN STUD PACK MUST BE FASTENED PER MECHANICALLY LAMINATED BUILT-UP COLUMN-NAILED - REFER TO 6A/S4.1

WALL STUD SCHEDULE				
TOP OF WALL	MAX PLATE HT	EXTERIOR WALL	INTERIOR NON-LOAD BEARING	PARTY WALL
ROOF	8" - 11 5/8"	2X6 NO.2 @ 16" O.C.	2X4 STUD @ 16" O.C.	2X4 STUD @ 16" O.C.
3RD	10" - 8"	2X6 NO.2 @ 16" O.C.	2X4 STUD @ 16" O.C.	2X4 STUD @ 12" O.C.
2ND	10" - 9 5/8"	2X6 NO.2 @ 16" O.C.	2X4 STUD @ 16" O.C.	2X4 STUD @ 8" O.C.

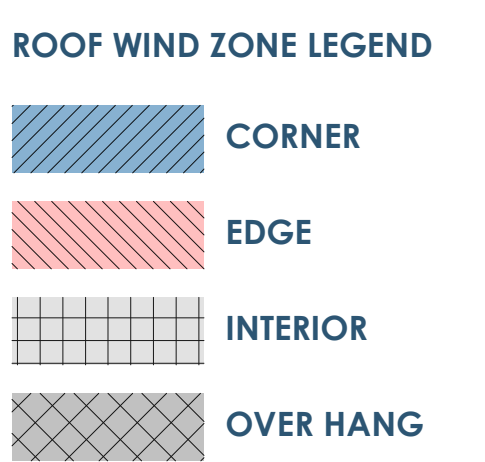

This project, like most OpeningDesign's projects, is open source (Attribution and ShareAlike are honored).