

502.7 IDENTIFICATION, WHERE ACCESSIBLE PARKING SPACES ARE REQUIRED TO BE IDENTIFIED BY SIGNS, THE SIGNS SHALL INCLUDE THE INTERNATIONAL SYMBOL OF ACCESSIBILITY COMPLYING WITH SECTION 703.6.3.1. SIGNS IDENTIFYING VAN PARKING SPACES SHALL CONTAIN THE DESIGNATION "VAN ACCESSIBLE." SUCH SIGNS SHALL BE 60 INCHES (1525 MM) MINIMUM ABOVE THE FLOOR OF THE PARKING SPACE, MEASURED TO THE BOTTOM OF THE SIGN.

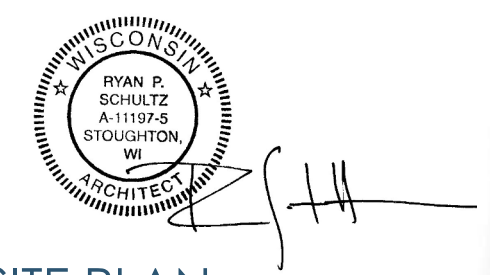
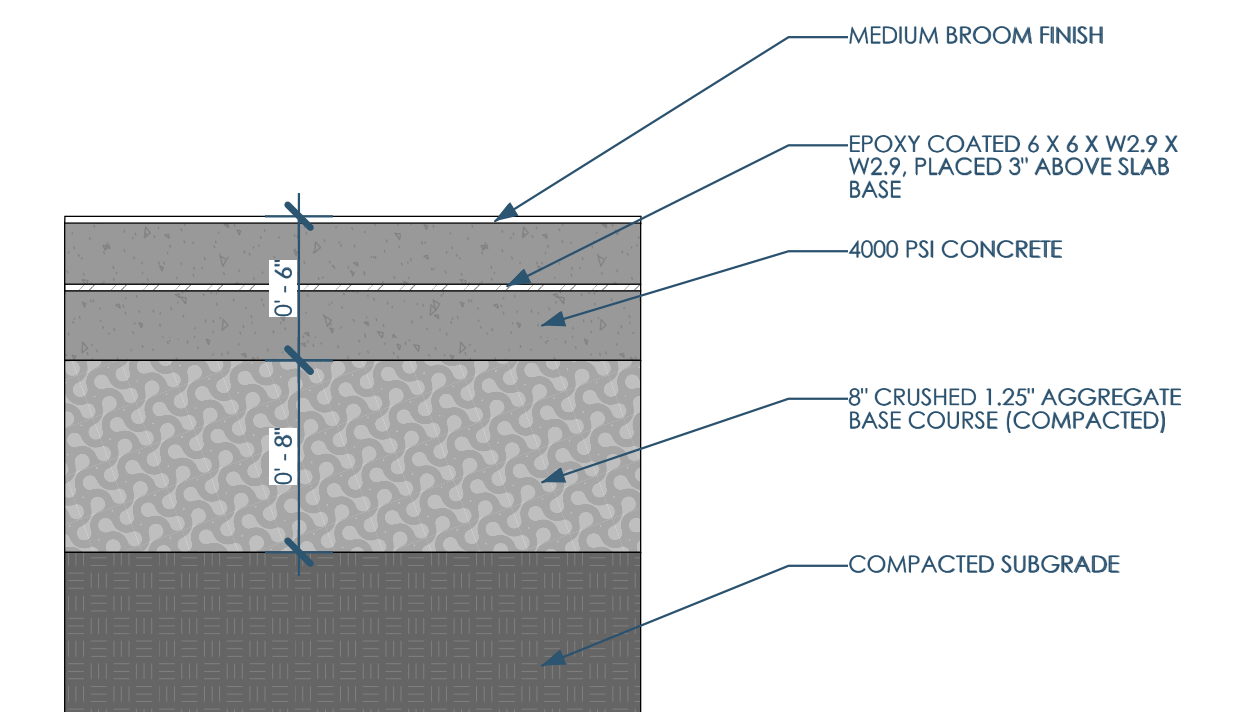
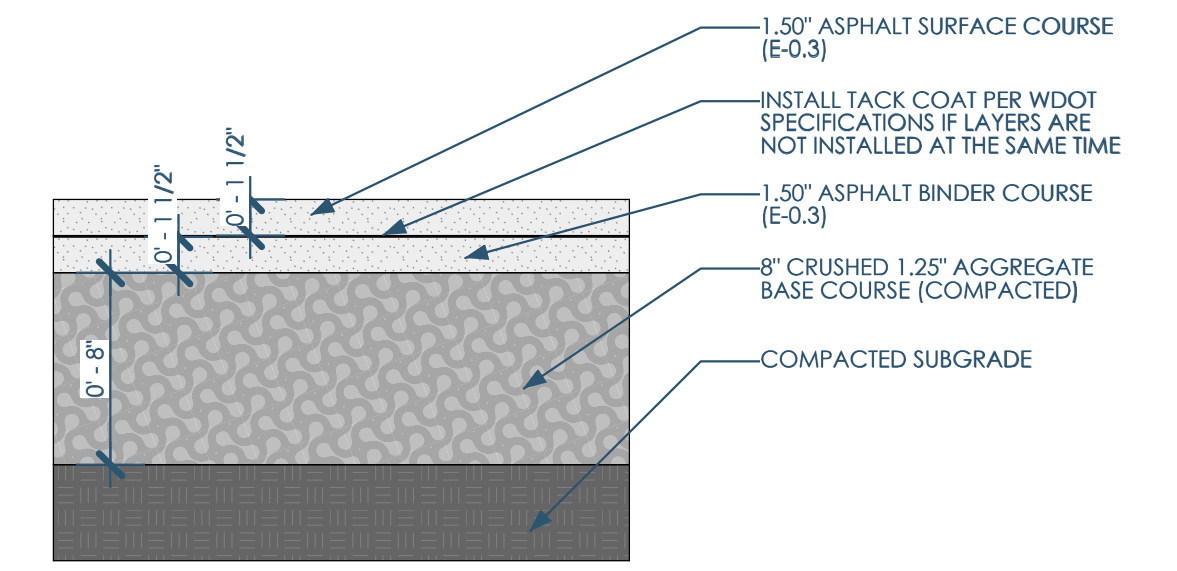
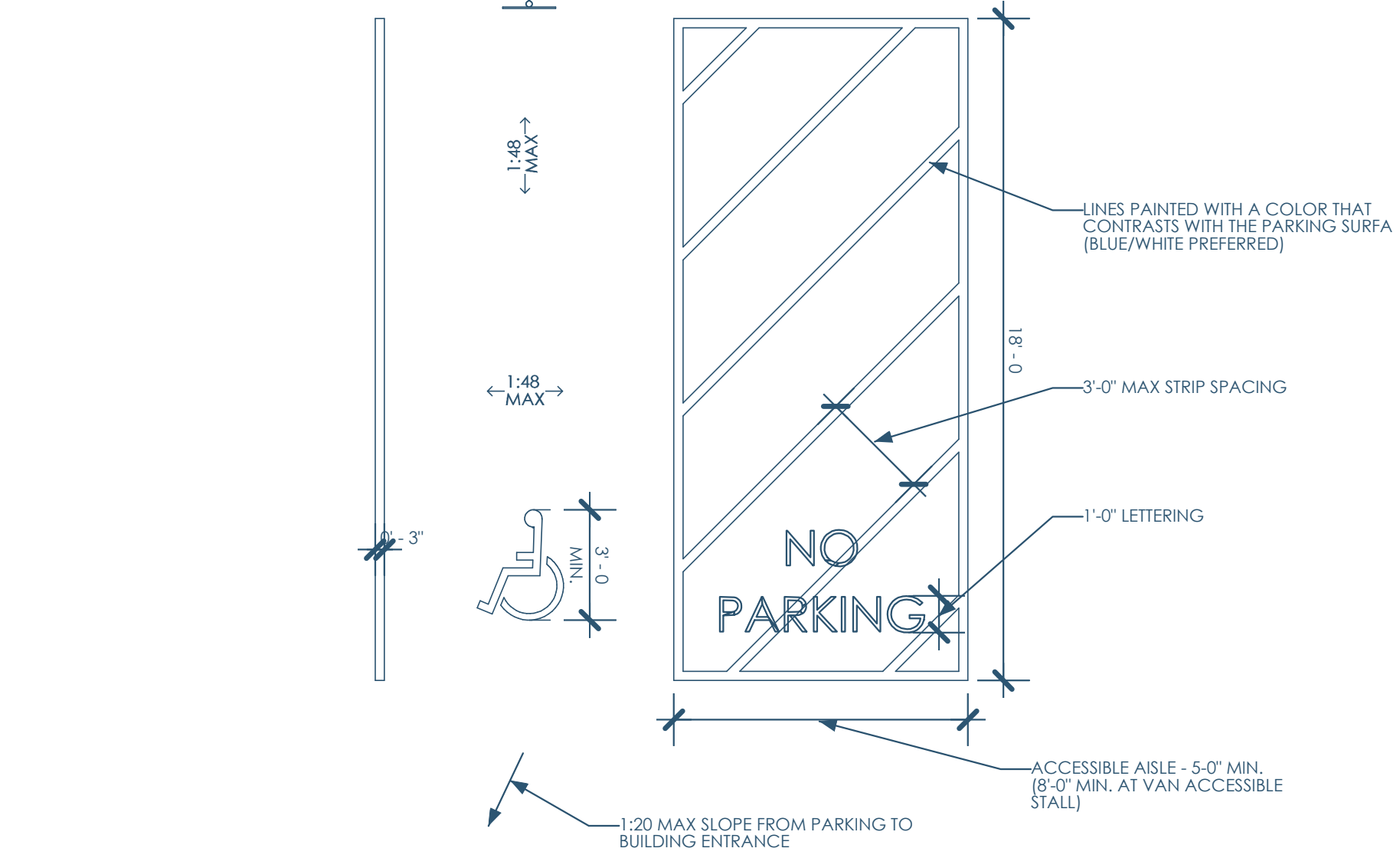

Owner: Kenlyn/Marquis German Shepherd Dogs
11714 N Eastman Rd
Edgerton, WI 53534-9051
Kentboylesgsd@aol.com | 608.884.8355

Structural: Ennovation
PO Box 148
Orfordville, WI 53576
kfrey@ennovationbuilt.com | 608.212.6998

Architect: OpeningDesign
17 S Fairchild | FL 7
Madison, WI 53703
ryan@openingdesign.com | 773.425.6456

SITE PLAN
BARN RELOCATION
389 E HEMENWAY LANE - EDGERTON, WI 53534
A001

This project, like most OpeningDesign's projects, is open source (Attribution-ShareAlike 4.0 International=CC-BY-SA 4.0) - freely available to any party for future use, assuming the terms such as Attribution and ShareAlike are honored.