

5C/A000 DEMO PLAN 1/16\"/>

**DEMOLITION NOTES**

- CONTRACTOR TO ASSUME ALL WALLS/COLUMNS INDICATED TO BE DEMOLISHED ON THE PLAN. TO BE LOAD BEARING, CONTRACTOR RESPONSIBLE TO MAKE THE DETERMINATION THEY ARE NOT LOAD BEARING, AND CAN BE REMOVED. CONSULT WITH THE ARCHITECT IF THERE IS ANY QUESTION.
- CONTRACTOR TO PROTECT ALL EXISTING CONSTRUCTION FROM DAMAGE AND DUST/FUMES AND PATCHED/REPAIRED AS NECESSARY.
- SEAL THE INTAKE/EXHAUST OF ANY DUCTS THAT ROUTE INTO ADJOINING SPACES THAT ARE OUTSIDE THE DEMOLITION SCOPE.
- CONTRACTOR TO COORDINATE THE DISCONNECTION AND CAPPING (AND ANY ASSOCIATED FEES) OF ANY SERVICE UTILITIES ASSOCIATED WITH THE DEMOLITION SCOPE.
- ALL FLOORS TO BE LEVELED AS NECESSARY (GRINDING, PATCHING, LEVELING, CHISELING) TO RECEIVE ANY SCHEDULE FINISHED.
- CONTRACTOR TO NOTIFY OWNER AND/OR LANDLORD OF ANY DEMOLITION THAT IS NECESSARY OUTSIDE TENANT SPACE.
- ADDITIONAL DEMOLITION, BEYOND WHAT IS IDENTIFIED HERE, MAY BE REQUIRED TO ACCOMMODATE THE PLANNED CONSTRUCTION SCOPE.
- OWNER/CC/SIRS ARE RESPONSIBLE TO TEST IF REMOVED ITEMS CONTAIN ANY HAZARDOUS MATERIALS AND IF SO, ARE LEGALLY REMOVED IN COMPLIANCE WITH LOCAL/STATE/FEDERAL LAWS.
- CONTRACTOR RESPONSIBLE FOR ANY TEMPORARY SHORING NECESSARY WHEN EXISTING STRUCTURAL MEMBERS ARE REMOVED TO ACCOMMODATE ANY NEW CONSTRUCTION. ALL SHORING TO BE DESIGNED BY A LICENSED STRUCTURAL ENGINEER RETAINED BY THE CONTRACTOR.
- SEE MECHANICAL/ELECTRICAL/PLUMBING/FIRE PROTECTION DRAWINGS FOR ANY ADDITIONAL DEMOLITION SCOPE.

5B/A000 DEMOLITION NOTES

**GENERAL RESTROOM NOTES**

PER IBC1910 2.2 WALLS AND PARTITIONS WITHIN 2 FEET (609MM) OF SERVICE SINKS, URINALS AND WATER CLOSETS SHALL HAVE A SMOOTH, HARD, NONABSORBENT SURFACE, TO A HEIGHT OF NOT LESS THAN 4 FEET (1219 MM) ABOVE THE FLOOR, AND EXCEPT FOR STRUCTURAL ELEMENTS, THE MATERIAL USED IN SUCH WALLS SHALL BE OF A TYPE THAT IS NOT ADVERSELY AFFECTED BY MOISTURE.

1210 2.1 FLOORS AND WALL BASES IN OTHER THAN DWELLING UNITS, TOILET, BATHING AND SHOWER ROOM FLOOR FINISH MATERIALS SHALL HAVE A SMOOTH, HARD, NONABSORBENT SURFACE. THE INTERSECTIONS OF SUCH FLOORS WITH WALLS SHALL HAVE A SMOOTH, HARD, NONABSORBENT VERTICAL BASE THAT EXTENDS UPWARD ONTO THE WALLS NOT LESS THAN 4 INCHES (102 MM).

1210 2.3 SHOWERS SHOWER COMPARTMENTS AND WALLS ABOVE BATHUBS WITH INSTALLED SHOWER HEADS SHALL BE FINISHED WITH A SMOOTH, NONABSORBENT SURFACE TO A HEIGHT NOT LESS THAN 72 INCHES (1829 MM) ABOVE THE DRAIN INLET.

5A/A000 GENERAL RESTROOM NOTES

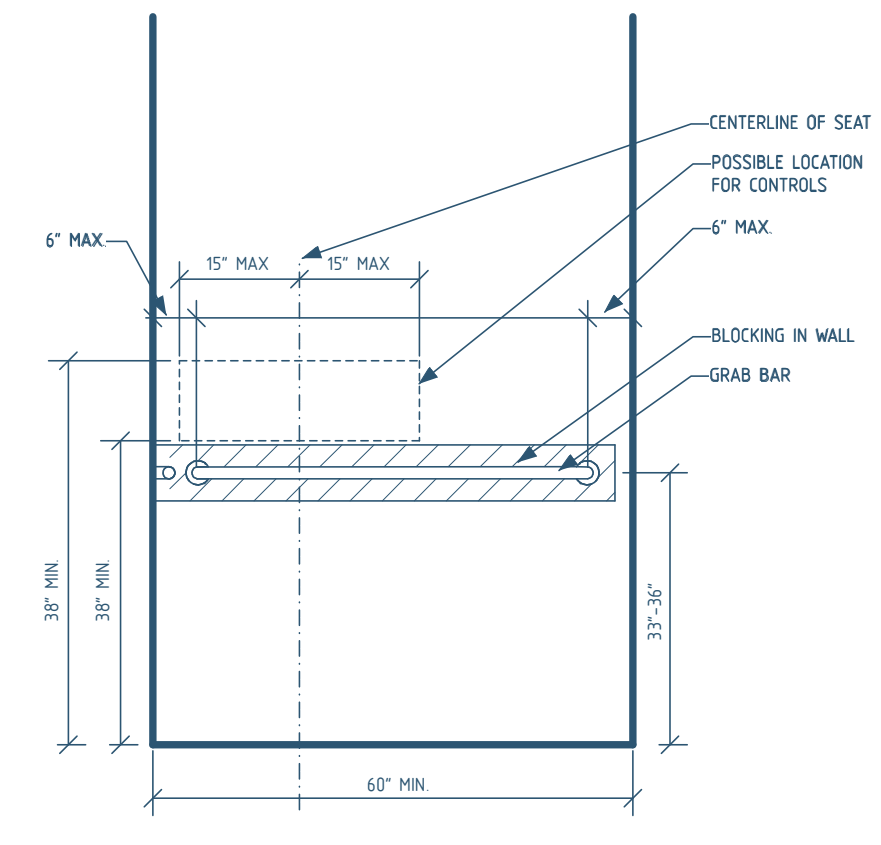

3C/A000 ADA - ALT. ROLL-IN-TYPE SHOWER - BACK WALL

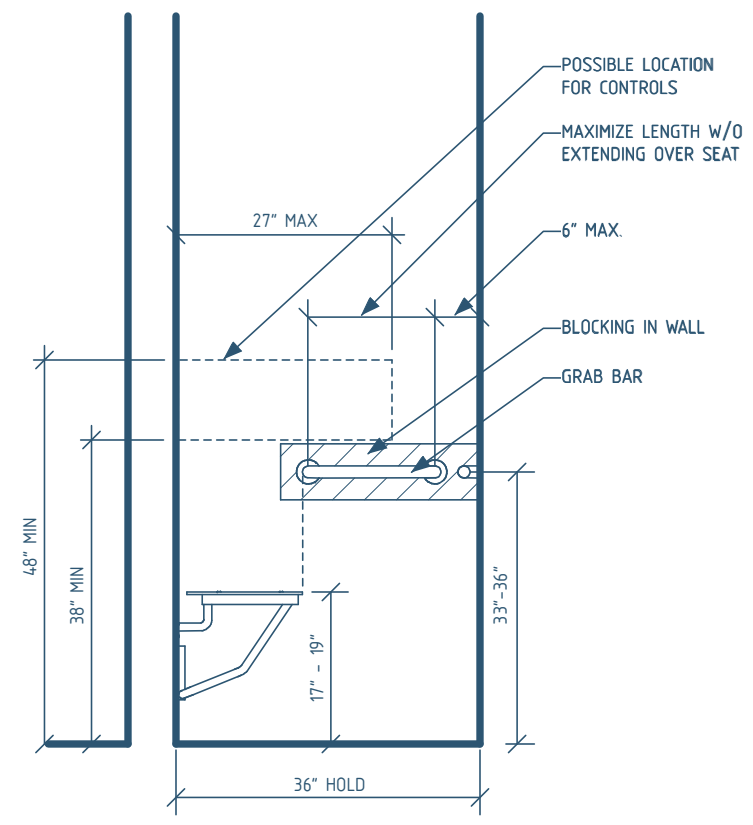

3B/A000 GENERAL NOTES

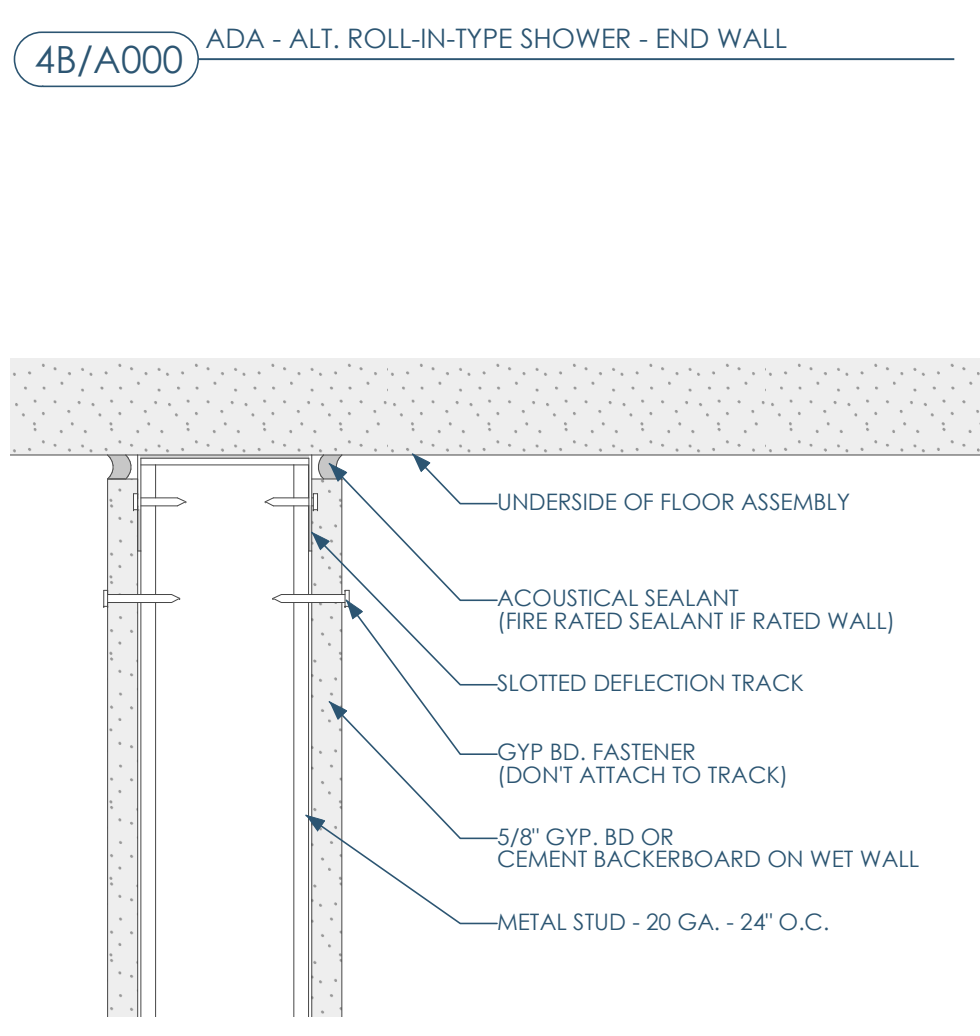

3B/A000 ADA - ALT. ROLL-IN-TYPE SHOWER - END WALL

4A/A000 W1 - FULL HEIGHT PARTITION - NOT RATED - HEAD 3\"/>

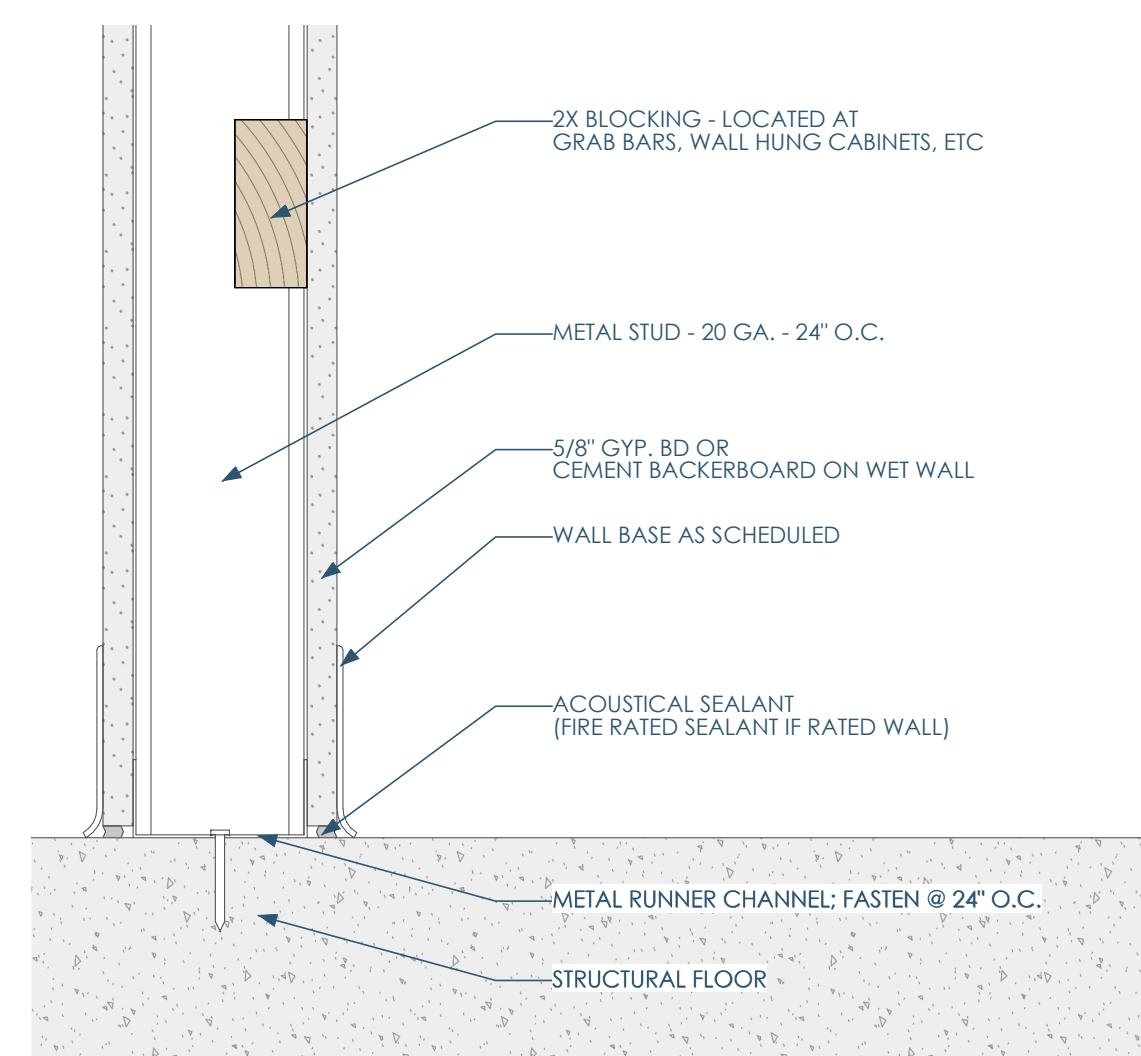

3A/A000 W1 - FULL HEIGHT PARTITION - NOT RATED - BASE 3\"/>

**GENERAL NOTES**

- THE MECHANICAL (HVAC), ELECTRICAL, PLUMBING, FIRE PROTECTION AND FIRE ALARM SYSTEMS WILL BE DESIGNED AND CONSTRUCTED USING THE DESIGN-BUILD DELIVERY METHOD. THESE SPECIFIC DETAILS ARE NOT PROVIDED IN THESE DOCUMENTS. IT IS THE RESPONSIBILITY OF THE M/E/P/FP/A CONTRACTOR TO COORDINATE WITH THE GENERAL CONTRACTOR AND UTILIZE THESE DRAWINGS TO GUIDE THE FINAL DESIGN OF THESE SYSTEMS. ANY CHANGES TO THE STRUCTURE OR ARCHITECTURAL FEATURES MUST BE COMMUNICATED TO THE ARCHITECT IN ADVANCE.
- GENERAL CONTRACTOR RESPONSIBLE FOR ALL FEES ASSOCIATED WITH PERMITS, APPLICATIONS, TAXES, AND CERTIFICATES OF INSPECTIONS.
- ANY CONSTRUCTION THAT DEVIATES FROM THE DRAWING IS UNAUTHORIZED, IF NOT AUTHORIZED BY THE ARCHITECT IN SUCH AN EVENT, CONTRACTOR IS RESPONSIBLE FOR ANY REMEDIATION THAT MUST BE REQUIRED.
- CONTRACTOR IS RESPONSIBLE FOR ALL THE RULES/REGULATIONS OF THE AUTHORITY HAVING JURISDICTION INCLUDED, BUT NOT LIMITED TO ALL CITY, TOWNSHIP, COUNTY, STATE, AND FEDERAL CODES, STATUTES, AND ORDINANCES.
- CONTRACTORS SHALL VISIT THE SITE PRIOR TO CONSTRUCTION TO DETERMINE HOW NEW CONSTRUCTION IS COMPATIBLE WITH EXISTING CONDITIONS.
- CONTRACTOR TO NOTIFY ARCHITECT IF THERE ARE ANY OMISSIONS, CONFLICTS, OR DISCREPANCIES IN THE DRAWINGS BEFORE ANY CONSTRUCTION TAKES PLACE. A FAILURE TO DO SO WILL RESULT IN THE CONTRACTOR BEING RESPONSIBLE FOR ANY REMEDIATION.
- CONTRACTOR RESPONSIBLE FOR VERIFYING ALL DIMENSIONS AND TAKEOFFS BEFORE BIDDING AND/OR ORDERING MATERIALS. CONTRACTOR WILL NOTIFY ARCHITECT IF THERE ARE ANY DRAWING CONFLICTS AND AWAIT DIRECTION BEFORE COMMENCING.
- DO NOT SCALE THE DRAWINGS.
- ALL THROUGH AND MEMBRANE PENETRATIONS AT ALL FIRE/SMOKE RATED PARTITIONS/CEILING/FLOORS TO BE SEALED WITH A CODE COMPLIANT, UL APPROVED FIRE STOP.
- GENERAL CONTRACTOR TO COORDINATE THE SIZE/LOCATION OF ANY ACCESS PANELS AND/OR CLEAN OUTS WITH THE M/E/P CONTRACTOR AND ARCHITECT.
- ALL CONTRACTORS AND VENDORS TO FAMILIARIZE THEMSELVES WITH THE ENTIRE DRAWING SET, AS REQUIRED INFORMATION MAY BE ON MULTIPLE SHEETS AND ALTERNATE DISCIPLINES.
- ANY FURNITURE SHOWN IS FOR REFERENCE ONLY.
- CONTRACTORS SHALL BE RESPONSIBLE FOR REPAIRING ANY PROPERTY DAMAGE THAT MAY HAVE RESULTED FROM THEIR WORK.
- OWNER RESPONSIBLE FOR ANY WORK NOT SPECIFICALLY CALLED OUT IN THE DRAWINGS.
- ANY CHANGE THAT RESULTS IN ADDITIONAL COST/TIME MUST TO APPROVED BY THE OWNER/ARCHITECT PRIOR TO CONSTRUCTION.
- DETAILS ARE TO BE INTERPRETED AS TYPICAL, THAT IS, UNLESS SPECIFICALLY CALLED OUT OTHERWISE, THE DETAIL IS TO BE APPLIED TO SIMILAR CONDITIONS THROUGHOUT THE PROJECT.
- ALL EXTERIOR FLATWORK AROUND THE BUILDING TO SLOPE A MINIMUM OF 2% AWAY FROM THE BUILDING.
- ANY PENETRATIONS IN THE EXTERIOR ENVELOPE TO BE SEALED TO PREVENT ANY AIR/WATER LEAKAGE PER IBC CODE REQUIREMENTS.
- ON THE DRAWINGS, NOTIFY ARCHITECT OF ANY PENETRATIONS IN THE EXTERIOR WALL THAT ARE LARGER THAN 1/2\"/>

COLUMN_1	COLUMN_2
APPLICABLE CODES:	GENERAL - INTERNATIONAL BUILDING CODE (IBC) 2015 & SPS 361-366 AMENDMENTS EXISTING - INTERNATIONAL EXISTING BUILDING CODE (IEBC) 2015 & SPS 366 AMENDMENTS ENERGY CONSERVATION - INTERNATIONAL ENERGY CONSERVATION CODE (IECC) 2015 & SPS 363 AMENDMENTS PLUMBING - WISCONSIN PLUMBING CODE SPS 380-387 MECHANICAL - INTERNATIONAL MECHANICAL CODE (IMC) 2015 & SPS 364 AMENDMENTS ELECTRICAL - NATIONAL ELECTRICAL CODE (NEC) 2017 & SPS 316 AMENDMENTS FIRE - INTERNATIONAL FIRE CODE (IFC) 2015 & SPS 314 AMENDMENTS FUEL - INTERNATIONAL FUEL GAS CODE (IFGC) 2015 & SPS 365 AMENDMENTS ACCESSIBILITY.
IBC - CHAPTER 3 USE AND OCCUPANCY CLASSIFICATION	SCOPE AREA - INSTITUTIONAL GROUP (I-4), DAY CARE FACILITIES (MOST RESTRICTIVE USE WITHIN SCOPE AREA) OUTSIDE SCOPE AREA - BUSINESS GROUP (B)
IBC - CHAPTER 5 CLASSIFICATION OF WORK	ALTERATION-LEVEL 2
IBC - 504.3 HEIGHT IN FEET	FOR TYPE V-B (W/ SPRINKLERS) - ACTUAL 39FT - ALLOWED - (B) 50FT - (I-4) 60FT
IBC - 504.4 NUMBER OF STORIES	- ACTUAL 3 STORIES - ALLOWED - (B) 3 STORIES - (I-4) 2 STORIES
IBC - 502.2 ALLOWABLE AREA DETERMINATION & 506.3 FRONTAGE INCREASE:	- ACTUAL 40,000 SF (13,333SF PER FLOOR) - (I-4) 5970 SF - (B) 34330 SF - ALLOWED - (I-4) - COMPUTE AREA INCREASE DUE TO FRONTAGE: FRONTAGE COEFFICIENT, $H = 0.75$ - PERIMETER, $P = 514$ FT - FRONTAGE PERIMETER, $F = 514$ FT - WEIGHTED AVERAGE DISTANCE FROM $P = 30$ FT - COMPUTE ALLOWABLE PER STORY AREA, $AA = AT \cdot (NS \cdot X \cdot IF) + 33750$ SQ.FT. - MAXIMUM ALLOWABLE AREA, $AA \cdot X^2 = 67500$ SQ.FT. - (B) - COMPUTE AREA INCREASE DUE TO FRONTAGE: FRONTAGE COEFFICIENT, $H = 0.75$ - PERIMETER, $P = 514$ FT - FRONTAGE PERIMETER, $F = 514$ FT - WEIGHTED AVERAGE DISTANCE FROM $P = 30$ FT - COMPUTE ALLOWABLE PER STORY AREA, $AA = AT \cdot (NS \cdot X \cdot IF) + 33750$ SQ.FT.
IBC - 508.3 NONSEPARATED OCCUPANCIES	NO
IBC - 508.4 SEPARATED OCCUPANCIES	YES - 1 HR FLOOR BETWEEN (I-4) AND (B)
IBC - TABLE 601 FIRE-RESISTANCE RATING REQUIREMENTS FOR BUILDING ELEMENTS (HOURS)	FOR TYPE V-B: STRUCTURAL FRAME: 0 HR BEARING WALLS- EXTERIOR: 0 HR BEARING WALLS-INTERIOR: 0 HR NON-BEARING WALLS-EXTERIOR - (SEE TABLE 602) NON-BEARING WALLS-INTERIOR: 0 HR FLOOR CONSTRUCTION: 0 HR ROOF CONSTRUCTION: 0 HR
IBC - TABLE 602 FIRE-RESISTANCE RATING REQUIREMENTS FOR EXTERIOR WALLS BASED ON FIRE SEPARATION DISTANCE	FOR TYPE V-B: FIRE SEPARATION DISTANCE - $X \leq 55' = 1$ HR - $5' \leq X \leq 10' = 1$ HR - $10' \leq X \leq 30' = 0$ HR - $X \geq 30' = 0$ HR
IBC - 803.11 INTERIOR FINISH REQUIREMENTS BASED ON GROUP	FOR I-4: INTERIOR EXIT STAIRWAYS AND RAMPS AND EXIT PASSAGEWAYS: CLASS B CORRIDORS AND ENCLOSURE FOR EXIT ACCESS STAIRWAYS AND RAMPS: CLASS B ROOMS AND ENCLOSURE: CLASS B
IBC - SPRINKLERS (SECTION 903 AUTOMATIC SPRINKLER SYSTEMS)	SPRINKLERS - NFPA 13
IBC - TABLE 906.3(1) FIRE EXTINGUISHERS FOR CLASS A FIRE HAZARDS	EVERYWHERE EXCEPT KITCHEN (IF APPLICABLE) - SEE TYPE K BELOW. TYPE OF HAZARD OCCUPANCY: ORDINARY (MODERATE) - TYPE 2-A - MAXIMUM FLOOR AREA PER UNIT OF A: 1500SF - MAXIMUM FLOOR AREA FOR EXTINGUISHER: 11250SF - MAXIMUM DISTANCE TO EXTINGUISHER: 75FT (IF APPLICABLE) COMM. KITCHENS W/ EQUIPMENT INVOLVING SOLID FUELS OR VEGETABLE OR ANIMAL OILS AND FATS TYPE OF HAZARD OCCUPANCY: ORDINARY (MODERATE) - TYPE K: 2.5-GALLON OR (2)1.5-GALLON (WITHIN 30FT OF COOKING EQUIPMENT)
IBC - SECTION 907 FIRE ALARM AND DETECTION SYSTEMS	EXISTING EXISTING MANUAL FIRE ALARM BOX IS CURRENTLY PRESENT. ANY NEW OR MODIFIED FIRE ALARMS OR FIRE ALARM BOXES TO INTEGRATE WITH EXISTING ONES ON THE PREMISES. FIRE ALARM TO BE DESIGN/BUILT PER 3RD PARTY.
IBC - SECTION 1004 OCCUPANT LOAD	SEE OCCUPANT LOAD ROOM SCHEDULE
IBC - SECTION 1020 CORRIDORS	CORRIDORS: 0 HR RATED (W/ SPRINKLERS)
IBC - 1006.2.1 EGRESS BASED ON OCCUPANT LOAD AND COMMON PATH OF EGRESS TRAVEL DISTANCE	FOR I-4: MAXIMUM COMMON PATH WITH SPRINKLER SYSTEM: 75FT MAXIMUM OCCUPANT LOAD OF SPACE WITH ONE EXIT: 10
IBC - SECTION 1017 EXIT ACCESS TRAVEL DISTANCE	FOR I-4: FOR B: 200 FT (W/SPRINKLER)
IBC - 1020.4 DEAD ENDS	50 FEET W/ SPRINKLERS
IEBC - 805.6 DEAD-END CORRIDORS	50 FEET PER IEBC - 805.6
2902.1 MINIMUM NUMBER OF FIXTURES	CLASSIFICATION: I-4 TOTAL OCCUPANTS: 82 FEMALE OCCUPANTS: 41 MALE OCCUPANTS: 41 - WATER CLOSETS: 1 PER 15 - WOMEN: 3 REQUIRED (2 PROVIDED) - MEN: 3 REQUIRED (2 PROVIDED) - LAVATORIES: 1 PER 15 - WOMEN: 3 REQUIRED (2 PROVIDED) - MEN: 3 REQUIRED (2 PROVIDED) - DRINKING FOUNTAINS: 1 PER 100 - (PROPOSED ALTERNATIVE: FAUCET IN KITCHEN) - SERVICE SINK: 1 REQUIRED (1 PROVIDED)

2A/A000 CODE INFORMATION

This project, like most OpeningDesign's projects, is open source. (Attribution-ShareAlike 4.0 International) - freely available to any party for future use, assuming the terms such as Attribution and ShareAlike are honored.